

Technical Manual

6040-6043

DATA TERMINALS

10, 15, 30, 60 cps

015-000051-00

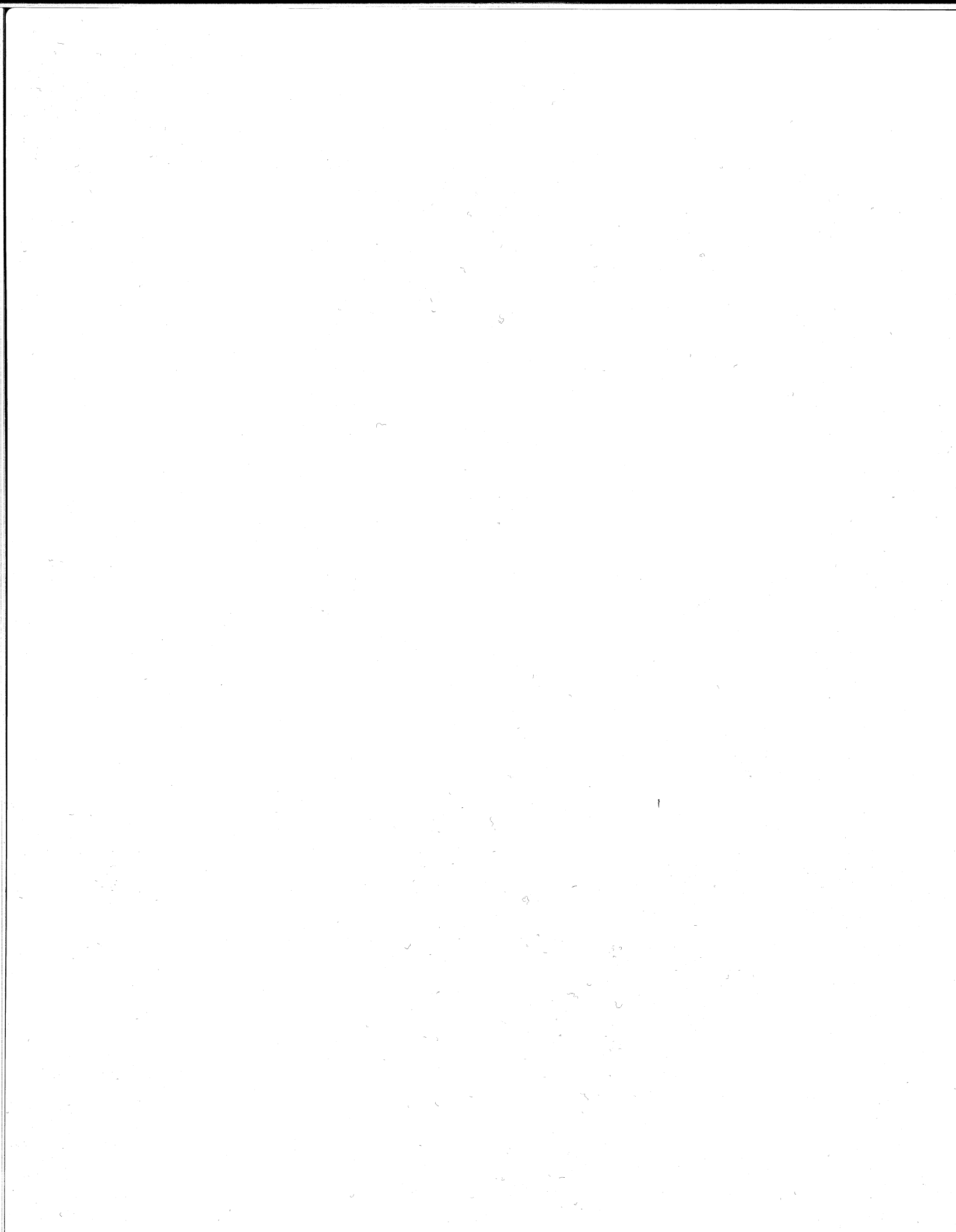

Technical Manual

6040—6043

DATA TERMINALS

10, 15, 30, 60 cps

015-000051-00

NOTICE

Data General Corporation (DGC) has prepared this manual for use by DGC personnel and customers as a guide to the proper installation, operation, and maintenance of DGC's equipment and software. The drawings and specifications contained herein are the property of DGC and shall neither be reproduced in whole or in part without DGC, prior written approval nor be implied to grant any license to make, use, or sell equipment manufactured in accordance herewith.

DGC reserves the right to make changes without notice in the specifications and materials contained herein and shall not be responsible for any damages (including consequential) caused by reliance on the materials presented, including but not limited to typographical or arithmetic errors, company policy and pricing information. The information contained herein on DGC software is summary in nature. More detailed information on DGC software is available in current released publications.

NOVA, SUPERNOVA, ECLIPSE and NOVADISC are registered trademarks of Data General Corporation, Southboro, Mass.

6040—6043
DATA TERMINALS
10, 15, 30, 60 cps

OVERVIEW

I

INSTALLATION

II

PROGRAMMER'S REFERENCE INFORMATION

III

OPERATING CONTROLS AND PROCEDURES

IV

THEORY OF OPERATION

V

OPERATOR MAINTENANCE

VI

APPENDICES

DataGeneral

This page intentionally left blank.

TABLE OF CONTENTS

SECTION 1 OVERVIEW

INTRODUCTION	I-1
SUMMARY OF CHARACTERISTICS	I-1
6040-6043 DATA TERMINALS	I-2
Printhead/Carriage Drive	I-3
Paper Feed Drive	I-3
Ribbon Drive	I-4
Keyboard and Operator's Control Panel	I-4
Logic Board, Power Supply, and Cabling	I-5
RELATED DOCUMENTS	I-5
Engineering Drawings	I-5
Manuals	I-5

SECTION II INSTALLATION

INTRODUCTION	II-1
INSTALLATION DATA SHEETS	II-1
PRELIMINARY CHECKOUT (6042)	II-2

TABLE OF CONTENTS (CONTINUED)

SECTION III PROGRAMMER'S REFERENCE INFORMATION

INTRODUCTION	III-1
PROGRAMMING SUMMARY	III-1
INSTRUCTIONS	III-2
Read Character	III-2
Write Character	III-2
PROGRAMMING	III-3
Input	III-3
Output	III-3
TIMING CONSIDERATIONS	III-3
Input	III-3
Output	III-3
Considerations for 600 Baud	III-3
PROGRAMMING EXAMPLES	III-4

SECTION IV OPERATING CONTROLS AND PROCEDURES

INTRODUCTION	IV-1
KEYBOARD (Models 6040, 6042)	IV-2
OPERATOR CONTROLS	IV-4
POWER SWITCH	IV-4
ON LINE/OFF LINE Switch and Indicator Light	IV-4
LINE FEED Switch	IV-4
VIEW ON/VIEW OFF Switch	IV-4
READY and PAPER FAULT Indicator Lights	IV-4
RIBBON ADVANCE, BAUD RATE Switches	IV-5

TABLE OF CONTENTS (CONTINUED)

OPERATING PROCEDURES	IV-5
Loading Paper	IV-5
Changing The Ribbon	IV-7
OPERATOR PRECAUTIONS	IV-9

SECTION V THEORY OF OPERATION

INTRODUCTION	V-1
BLOCK DIAGRAM OF THE DATA TERMINAL	V-1
INTERFACE AND CHARACTER BUFFER	V-5
Receiver Transmitter (UART)	V-5
Character Buffer (FIFO)	V-6
Terminal Busy Flag	V-8
CHARACTER PRINTER	V-9
Printhead/Carriage Assembly	V-9
Print Controller	V-10
Solenoid Drivers	V-10
PRINTHEAD POSITIONER	V-11
Carriage Drive	V-11
Position Controller	V-12
Carriage Drive Motor	V-12
Timing Transducers	V-14
Print Sequence	V-14
Carriage Return Sequence	V-15
View Sequence	V-18
PAPER FEED SYSTEM	V-19
Paper Feed Mechanism	V-19
Paper Feed Controller	V-20
RIBBON FEED	V-20
Ribbon Drive	V-20
Ribbon Control	V-22

TABLE OF CONTENTS (CONTINUED)

POWER SUPPLY	V-23
Pulse Width Modulated Switching Regulators	V-25
Over Current Protect	V-26
Over Voltage Protect	V-26
Under Voltage Protect	V-26
Reset (+5Vdc Under Voltage)	V-26
External Fault	V-26
FAULT DETECTORS	V-27
Over Voltage Fault	V-27
Head Fault	V-27
Home Fault	V-27
Reverse Fault	V-27
Paper Fault	V-27
Reset	V-28

SECTION VI OPERATOR MAINTENANCE

INTRODUCTION	VI-1
EVERY WEEK	VI-1
EVERY MONTH	VI-2

APPENDIX A TECHNICAL SPECIFICATION

6042/6043	A-1
6040/6041	A-2

TABLE OF CONTENTS (CONTINUED)

APPENDIX B

CHARACTER SETS

INTRODUCTION	B-1
95-Character Subset	B-1
64-Character Subset	B-1
UNITED STATES USAGE	B-2
UNITED KINGDOM USAGE	B-4
GERMAN USAGE	B-6
FRENCH USAGE	B-8
SWEDISH USAGE	B-10
JAPANESE USAGE	B-12

Data General Corporation (DGC) has prepared this manual for use by DGC personnel and customers as a guide to the proper installation, operation, and maintenance of DGC equipment and software. The drawings and specifications contained herein are the property of DGC and shall neither be reproduced in whole or in part without DGC's prior written approval nor be implied to grant any license to make, use, or sell equipment manufactured in accordance herewith.



SECTION I OVERVIEW

Data General's 6042 series hard copy data terminal, shown at left, is a free standing unit with: 128 code, ASCII-compatible, capacitor switched, keyboard; 5x7 dot matrix, character-serial, upper/lower case, printer; and integral bit-serial, asynchronous, interface to 20ma current loop and EIA (RS 232-C) controllers. Character transfer rate is selectable to 10, 15 or 30 cps. The terminal is fully plug compatible with all Data General teletypewriter interfaces and modems; the terminal is entirely upward-compatible with DGC software designed to drive teletypewriters. A receive (printer) only version, model number 6043, is also available.

INTRODUCTION

Hard copy data terminals have principal applications where a printed record of the dialogue between a user and the computer system is important, or where low volume report generation does not require higher speed and higher cost output printers. They are particularly useful for computer system maintenance or troubleshooting; most Data General diagnostic and reliability test programs presume that at least one teletypewriter-like terminal be available for user prompts and statistical printouts.

The 6040-6043 terminals are quiet, reliable, replacements for teletypewriter equipment previously offered by DGC for NOVA,[®] ECLIPSE,[®] and micro-NOVA computer systems. They combine a high performance, electronic keyboard with a stepper-controlled printer and a paperfeed mechanism using a minimum of moving parts. Electronic circuitry is contained on one large printed circuit board.

Model 6042 is the basic teletypewriter replacement, providing true 30cps throughput when used with Data General's standard communications hardware and software. Model 6040 is a speed-enhanced terminal offering 60cps throughput; DGC recommends its use with a particular I/O controller* to maintain full compatibility with DGC software. General specifications for the terminals are summarized in the table to the right; complete specifications for each model are presented in Appendix A.

* Model 4010 modified as described in Data Sheets: DGC no. 010-000094. The 6040 or 6041 terminal is electrically compatible with Data General asynchronous controllers. Timing constraints imposed at 600 baud by some of the controllers can require that fill characters be inserted by the program.

SUMMARY OF CHARACTERISTICS

Character Set (Appendix B)	6 Standard ASCII character sets: AMERICAN, FRENCH, GERMAN, SWEDISH, UK, and ASCII/JAPANESE. Lower/upper case character foldover, jumper selectable. An additional 29 symbols can be enabled; these correspond to character codes usually ignored by most terminals; the symbols in this "extended" set of characters are ASCII standard "control" symbols.
Character Style	5 x 7 dot matrix, inclined 10 degrees to the right.
Character Size	Approximately 0.082" (base) 0.107" (height)
Printing Size	10 characters per inch (horizontal) 132 characters per line (maximum) 6 characters per inch (vertical)
Character Buffer	(interface to printhead) 40 characters, FIFO
Keyboard Type	3-level, capacitor-switched, electronically debounced unlimited key-rollover (ordered by falling keystroke)
Keyboard Layout	ANSI standard, typewriter-paired
Printing Speed (Maximum)	6040/6041: 30cps(normal) 60cps(catch-up) @300 baud 6042/6043: 60cps @600 baud
Forms	pin feed forms only (1/2" centers) Minimum - 4" wide; Maximum - 15" wide
Multiple Forms	6-part forms, maximum (top sheet must be paper) 0.025" maximum form pack
Ribbon Type	0.5" x 80yds. mylar or 40yds. ink impregnated fabric multi-pass on each half of ribbon; auto-reversing
Control Codes	015 CR (Carriage Return) 007 BEL (tone) 012 LF (Line Feed) 177 DEL is ignored
Carriage Return	600ms for 132 column return
Line Feed	33ms/line
AC voltages	120V (standard), 100V, 240V, and 220V tolerances: +10% - 15% V, 47Hz-63Hz
Dimensions	33.75" (h), 21" (d), 26.5" (w) all models are free-standing and pedestal-mounted

6040 - 6043 DATA TERMINALS

Each data terminal is an electromechanical device which communicates with the computer system through a device cable. Mechanical and electrical components within the terminal interact to perform terminal functions. The various components may be conveniently grouped into five systems: the printhead/carriage drive, the paper feed drive, the ribbon drive, the keyboard (6040 and 6042 only) and operator control panel, and the logic/control/interface board, power supply and cabling system. All are contained in a free-standing enclosure, and their relative locations are shown in the figure below. Each system is shown isolated on the facing page, and a brief functional description of each is included there. More detailed descriptions of the components and their operation may be found in Section V of this

manual. Adjustment and repair procedures for these systems are detailed in the 6042 - 6043 Field Service Maintenance Manual. (DGC no. 015-000052.)

The enclosure consists of a stamped metal pedestal and an injection molded, two piece housing, whose top cover swings open to expose all mechanical systems. Panels on the sides of the pedestal provide access to the logic board and power supply. The systems are modular in construction and are designed with a minimum of moving parts to minimize wear and maximize service life. The assemblies are easily removed, replaced and adjusted in the field. The drawing below is a left-front view of the terminal, with the top cover open and the five systems emphasized. The drawings on the facing page show each system in the same perspective as below.

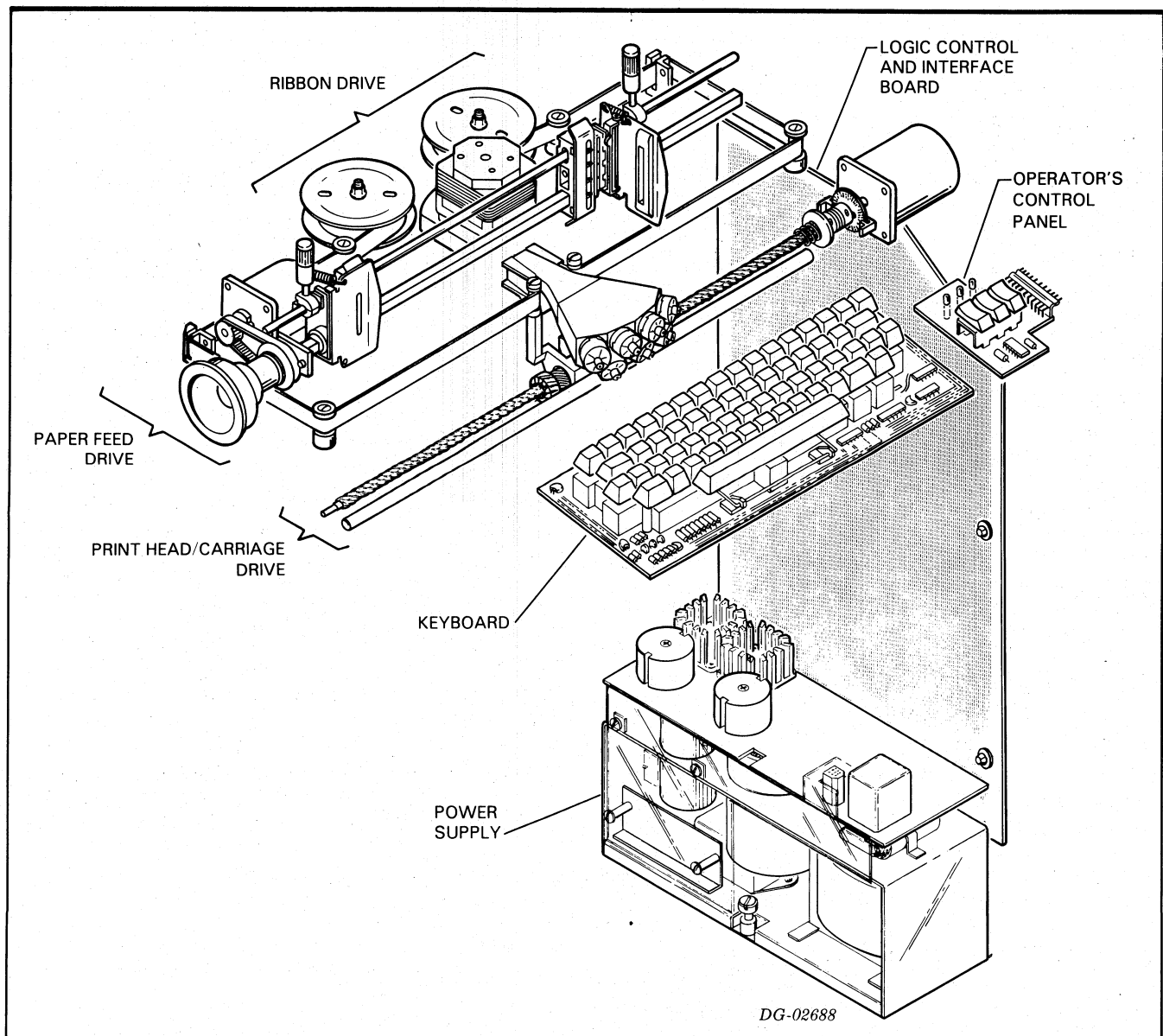

Data General Corporation (DGC) has prepared this manual for use by DGC personnel and customers as a guide to the proper installation, operation, and maintenance of DGC equipment and software. The drawings and specifications contained herein are the property of DGC and shall neither be reproduced in whole or in part without DGC's prior written approval nor be implied to grant any license to make, use, or sell equipment manufactured in accordance herewith.

Printhead/Carriage Drive

An anti-backlash feed screw and a permanent magnet stepping motor move the dot matrix printhead and

carriage across the platen during carriage returns and printing operations. Signals from the timing transducer also trigger the printhead solenoids when a character is printed.

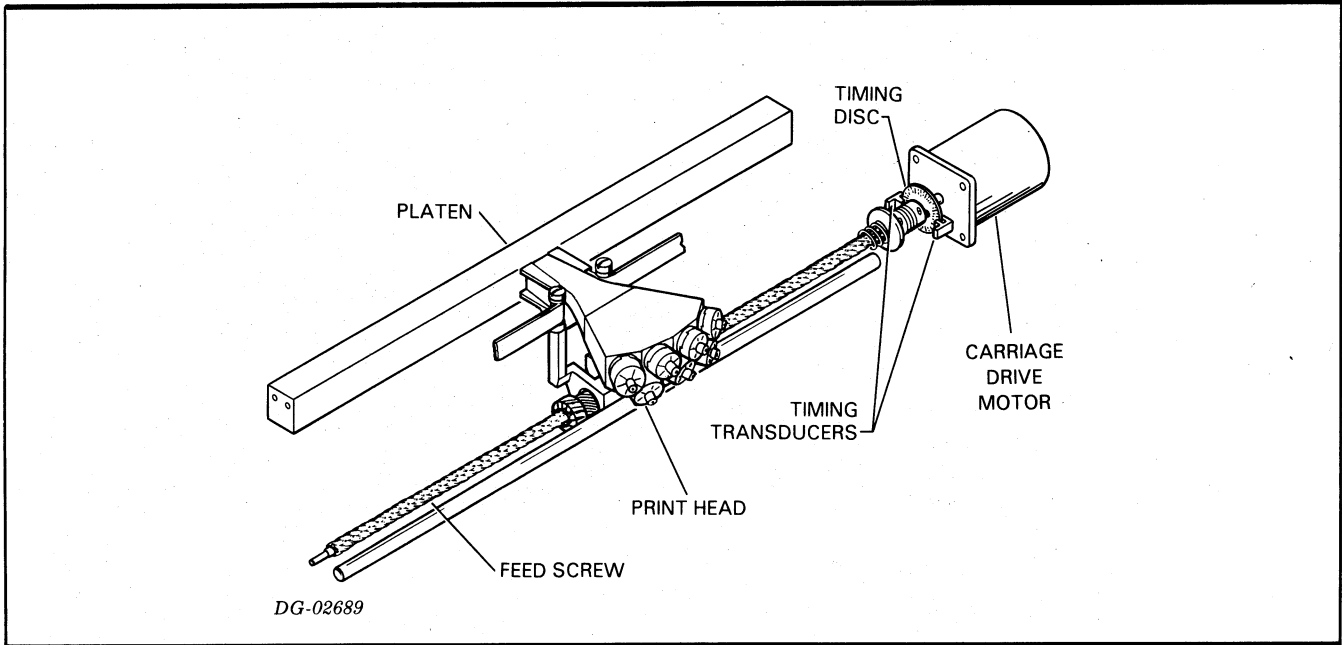

Paper Feed Drive

Pin feed tractor assemblies, driven by a stepping motor via a timing belt, advance the paper one line at

a time. The tractors are easily adjustable to accommodate different paper widths; a vernier adjustment knob provides manual paper height control.

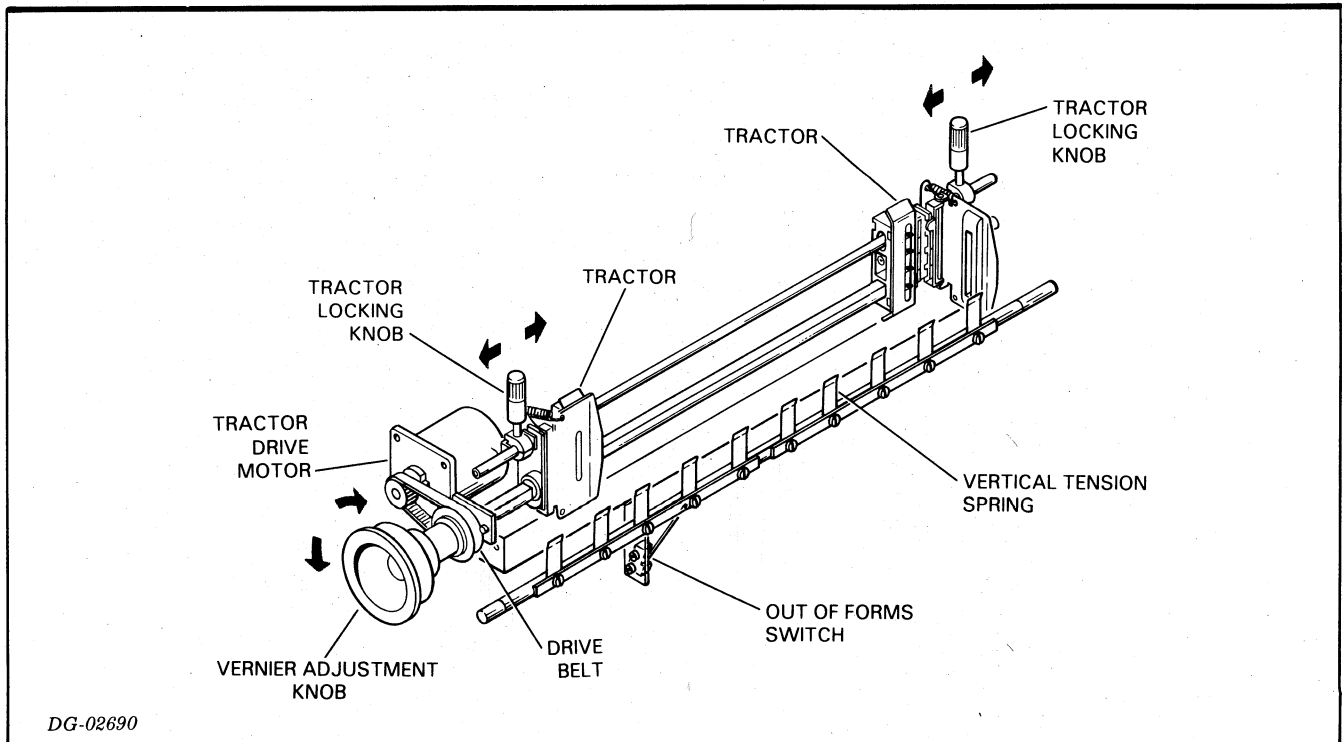

Data General Corporation (DGC) has prepared this manual for use by DGC personnel and customers as a guide to the proper installation, operation, and maintenance of DGC equipment and software. The drawings and specifications contained herein are the property of DGC and shall neither be reproduced in whole or in part without DGC's prior written approval nor be implied to grant any license to make, use, or sell equipment manufactured in accordance herewith.

Ribbon Drive

The drive motor winds the ribbon from spool to spool during carriage returns, and couples to the driven spool via a swing arm gear train. Ribbon reversing switches automatically reverse ribbon direction when the supply spool is empty.

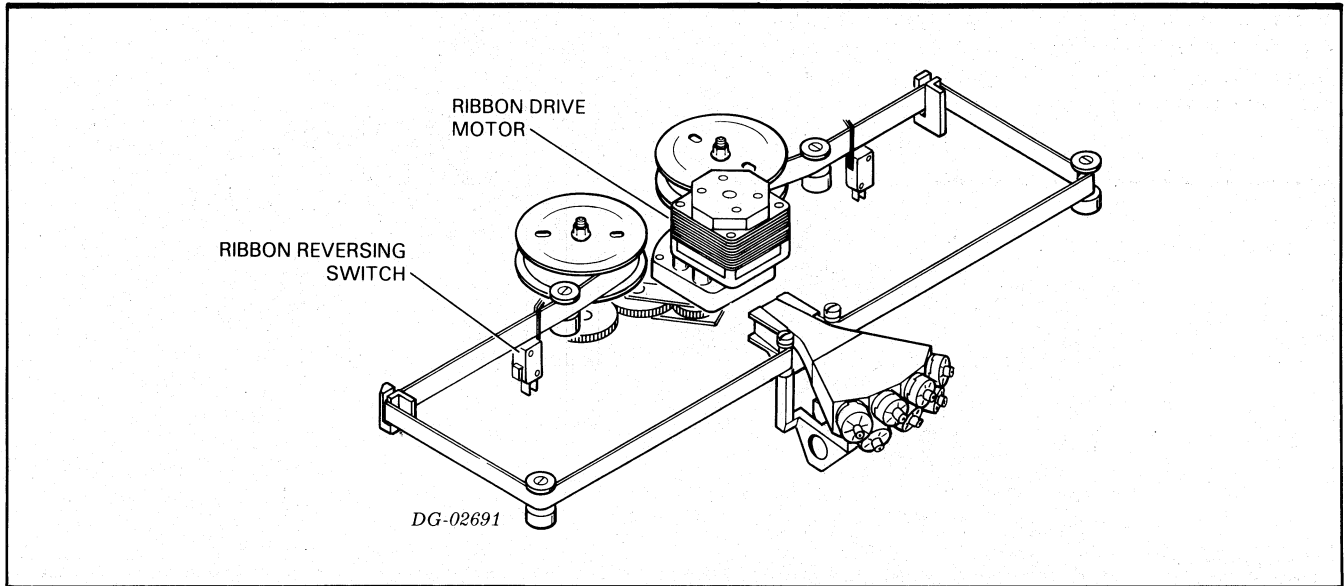

Keyboard and Operator's Control Panel

The keyboard may generate all 128 USASCII codes. N-key rollover is standard. The control panel contains switches and indicator lights for operator functions.

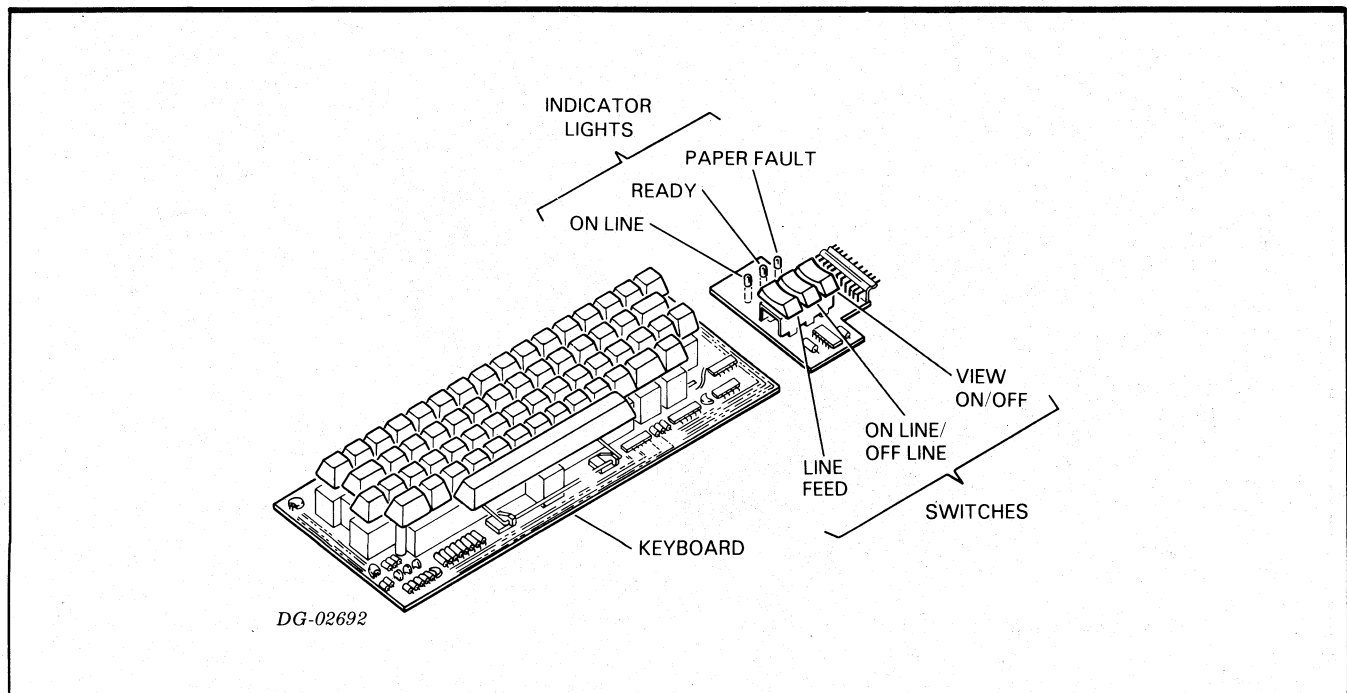

Data General Corporation (DGC) has prepared this manual for use by DGC personnel and customers as a guide to the proper installation, operation, and maintenance of DGC equipment and software. The drawings and specifications contained herein are the property of DGC and shall neither be reproduced in whole or in part without DGC's prior written approval nor be implied to grant any license to make, use, or sell equipment manufactured in accordance herewith.

Logic Board, Power Supply, and Cabling

The interface, decoder, and control circuits are located on one printed circuit board, accessible through a panel on the outer side of the pedestal. The power supply is contained in a sheet metal bracket, accessible through a panel on the inner side of the pedestal. Large power supply components are located inside the bracket, and the remainder of the power supply is contained on a small printed circuit board on top of the bracket. Cables carry control and power signals among the terminal's systems; all connections are made through plugs.

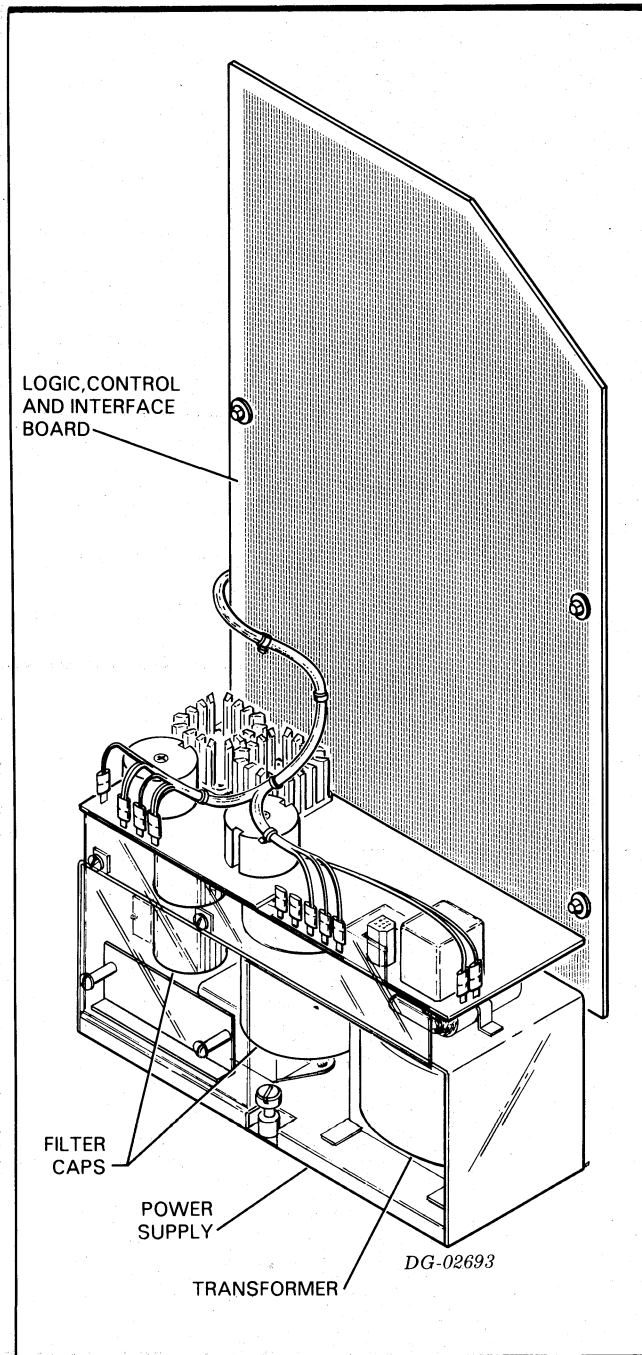

RELATED DOCUMENTS

Engineering Drawings

- 001-000963 Printer Logic and Control
- 001-000964 Printer Power Supply
- 010-000094 Installation Data sheets 6040-6043 terminals
- 016:000380 Mechanical IPL, 6040-6043 terminals
- 016-000379 Electro-Mechanical IPL, 6040-6043 terminals

Manuals

- 015-000052 6042-6043 Field Service Maintenance Manual
- 015-000021 Programmer's Reference Manual-Peripherals
- 015-000031 Interface Designer's Manual
- 015-000023 Programmer's Reference Manual
Nova Line Computers

Data General Corporation (DGC) has prepared this manual for use by DGC personnel and customers as a guide to the proper installation, operation, and maintenance of DGC equipment and software. The drawings and specifications contained herein are the property of DGC and shall neither be reproduced in whole or in part without DGC's prior written approval nor be implied to grant any license to make, use, or sell equipment manufactured in accordance herewith.

This page intentionally left blank.

SECTION II INSTALLATION

INTRODUCTION

This section describes the on-site installation of the 6040-6043 data terminals. Each terminal is a free-standing unit which is connected to the computer system by a 4- or 6- wire device cable and may be used in a variety of applications using one of many Data General asynchronous communications interfaces, such as the line multiplexors, asynchronous interfaces, or the standard teletypewriter controller.* Models 6042 and 6043 operate at three different data transmission rates (110, 150, or 300 baud), and with 20mA current loop or voltage level (EIA standard) interfaces. Models 6040 and 6041 operate at two different data transmission rates (300 baud or 600 baud). The 4000 controller and the 4010 controller modified for 6040/6041 operation at 600 baud is intended for 20mA current loop operation only. The 6040/6041 can, however, operate with DGC's asynchronous controllers with both current loop and voltage level interfaces.

Installation consists of choosing a site for the terminal, unpacking it, placing it in position, installing the controller interface in the computer system, and connecting the cable. When the terminal is obtained with a complete Data General computer system, the controller will be installed in the system at the factory. However, when the terminal is obtained as an addition to an existing computer system, the customer must interface the terminal to the desired computer system component.

* Model 4010 modified as described in Data Sheets: DGC no. 010-000094. The 6040 or 6041 terminal is electrically compatible with Data General asynchronous controllers. Timing constraints imposed at 600 baud by some of the controllers can require that fill characters be inserted by the program.

INSTALLATION DATA SHEETS

Installation details may be found in the installation data sheets included with the equipment. These drawings provide information useful to both the installer and the system designer. The drawings contain information necessary to configure the terminal into a computer system and to install the terminal. They are divided into blocks of data which are presented in the order the information is used. The first blocks describe the system components and tabulate operating specifications. They include such information as space and power requirements, and they also describe modifications recommended for operating the 6040/6041 terminals at 600 baud with DGC's 4010 teletypewriter controller.

The remaining data blocks contain information necessary to install the terminal at the installation site. The blocks are arranged in the order of installation, and have captions which are self-explanatory. Data blocks describing most controller installations are not included in the data sheets due to the large variety of possible interfaces; but the modifications recommended for operating a 6040 or 6041 terminal at 600 baud with DGC's model 4010 teletypewriter controller are included. Typical cabling schemes are shown for some specific applications. Electrical interfacing requirements for the printer are listed on the data sheet for 20mA or EIA standard transmission line characteristics; this information is required to properly connect the terminal to the controller used in the system.

PRELIMINARY CHECKOUT

Data General recommends a preliminary checkout of a terminal after it is uncrated, to ensure that the electro-mechanical assemblies and control logic function correctly. Such a checkout procedure is described below. Unpack the terminal and remove the shipping restraints as described in the installation data sheets. Plug the terminal into the ac line supply receptacle and then load paper and ribbon as described in the operator's section of this manual.

There are two parts to the checkout; the first tests the electromechanical functions of the terminal operating off-line from the computer, while the second tests these functions when it is operating on-line with the computer. Some of the tests cannot be performed with receive-only models. (The diagram to the right shows the location of most operator controls.)

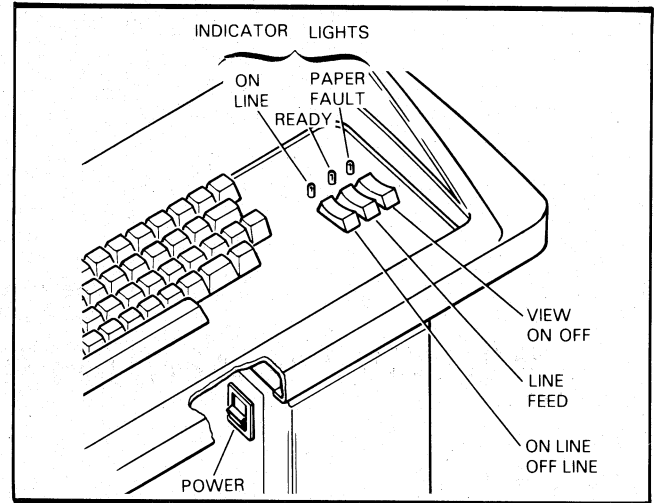

OFF LINE CHECKOUT

Procedure	Expected Result
Set the ON LINE/OFF LINE switch to the OFF LINE position. Turn the POWER switch ON.	The cooling fan spins and the READY light glows. The printhead returns to the left margin.
Type a line of text, without a carriage return.	The text is printed as typed.
Type LINE FEED.	The paper advances one line.
Type more text, followed by a carriage return.	The text is printed as typed, and the printhead returns to the carriage home position. The paper does not advance.
Depress the LINE FEED switch several times. (Backward)	The paper advances one line for each depression of the switch.
Hold the LINE FEED switch (Forward).	The paper advances continually while the switch is held.
Place the VIEW ON/VIEW OFF switch to the VIEW ON position, and type a line of text, pausing at several places for at least 1.2 seconds.	The text is printed as typed. At each pause of 1.2 seconds or more, the printhead moves clear of the text by 6 character positions.
Place the VIEW ON/VIEW OFF switch to the VIEW OFF position; repeat the preceding step.	The text is printed as typed. The printhead does not move clear of the text during lapses in typing.
Depress an alphanumeric key and the RPT key simultaneously.	The terminal repetitiously prints the alphanumeric character. The printer stops when either key is released.

This completes the off-line preliminary checkout of the data terminals. Proceed to install the terminal in accordance with the installation data. Ensure that the BAUD RATE switch setting agrees with the controller's baud rate. Check on-line operation as follows:

ON LINE CHECKOUT

Procedure	Expected Result
Turn the POWER switch ON. Set the ON LINE/OFF LINE switch to the ON LINE position.	The cooling fan spins and the READY light glows. The printhead returns to the left margin. The ON LINE indicator light glows.
Turn on the computer power, load the following "echo" program into memory locations 0 - 6 via the CPU console switches; then reset and start the computer.	No visible result on the terminal. The computer's RUN light glows.
063610	;SKPDN TTI
000777	;JMP .-1
060610	;DIAC 0,TTI (CODE 10)
063511	;SKPBZ TTO
000777	;JMP .-1
061111	;DOAS 0,TTO (CODE 11)
000000	;JMP 0
Repeat the off-line checkout (previous column). The results should be identical.	

This completes the preliminary checkout of the terminals. If any expected result is not obtained, check cabling connections, baud rate switch setting, echo program coding, and input power, and repeat these procedures. If the unit still fails to function correctly, contact the nearest Data General Field Service representative for assistance.

SECTION III PROGRAMMER'S REFERENCE INFORMATION

INTRODUCTION

This section describes the programming instructions and conventions used with the DGC's data terminals, models 6040 thru 6043. The 6040 or the 6042 data terminal is a self contained, free-standing, keyboard send and receive (KSR) input/output terminal which responds to and transmits serial character codes. The 6041 or the 6043 terminal is a receive-only printer. All data transfers take place in bit-serial fashion via a 20mA current loop or an EIA interface, at baud rates of 110, 150, or 300 bits per second.

The table at right summarizes the programming information for Data General's basic I/O controllers as presented in this section. It can serve as a quick reference guide for the programmer.

Data moves between the terminal and the interface in full duplex transmission mode; that is, the terminal appears as two separate devices when operated on-line. The keyboard is the input device and the printer is the output device. Because they appear as two separate devices, the program must echo each character entered at the keyboard if the characters are to be printed as they are typed.

All the exchanges of data between the keyboard and the computer and between the computer and the printer utilize the ASCII code given in Appendix B. While the keyboard generates the full 128-character ASCII alphanumeric code, the printer responds to a subset of this character code. The characters which the terminals print depends on certain jumper positions located on the main logic board. Subsets of printable characters are defined in Appendix B.

PROGRAMMING SUMMARY

Primary Mnemonic	
Transmitter	TTI
Receiver	TTO
Primary Device Code	
Transmitter	10
Receiver	11
Secondary Mnemonic	
Transmitter	TTI1
Receiver	TTO1
Secondary Device Code	
Transmitter	50
Receiver	51
Priority Mask Bit	
Transmitter	14
Receiver	15
Characters/line	132
Lines/inch	6
Average Transfer Rate (cps, model 6042/43)	30

ACCUMULATOR FORMATS

Read Character (DIA to TTI)

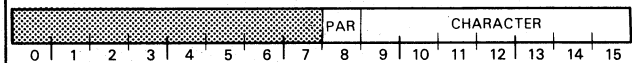

Write Character (DOA to TTO)

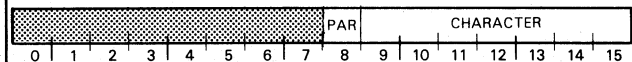

S, C, and P FUNCTIONS

- f = S Sets the Busy flag to 1 and the Done flag to 0. No effect on receiver; initiates transmission of character to terminal.
- f = C Sets the Busy flag to 0 and the Done flag to 0. Terminates all data transfers; if issued before transmission is completed, a partial character code will be received at the terminal.
- f = P No effect.

Parity output from the keyboard is selectable to odd, even, or no parity, and must agree with that expected by the program. Installation Data Sheets describe how to select parity. The printer does not test incoming data for parity errors, but the parity (or eighth) bit is required for correct framing.

The horizontal column spacing is ten characters per inch. Vertical lines print with a spacing of six lines per inch. A maximum line length of 132 characters can be printed. The printer will accommodate forms as narrow as 4 inches in width, and up to a maximum of 15 inches in width.

The printer's vertical spacing allows standard 66 line pages to fit on 11 inch fanfolded forms. The terminal does not respond to form feed codes (14_8); to position the printing form at "top of form," the program must issue an appropriate number of line feeds (12_8) to start a new page of printing.

The terminal interfaces to the I/O bus of any NOVA® or ECLIPSE® line CPU through the 4007/10 controller, the 4075/80 controller, and to a wide variety of asynchronous, serial data controllers.* A description of the programming and sample programs for reading, writing, and echoing characters with a simple I/O controller, such as the 4010, are given as general programming examples. When programming the terminal interfaced with another controller, consult the technical data for the specific controller used.

INSTRUCTIONS

The following instruction definitions and timing information are for the terminal used in conjunction with a DGC 4007/4010 controller.

The controller contains two independent character buffers, an 8-bit Input Buffer and an 8-bit Output Buffer.

The controller's Busy and Done flags are controlled using two of the device control flag commands as follows:

- f = S** Sets the Busy flag to 1, the Done flag to 0. Has no effect on the receiver, initiates the transmission of a character from the output buffer to the terminal.
- f = C** Sets both the Busy and Done flags to 0 and terminates data transfers. A CLEAR command issued during character transmission will cause a partial character code to be sent to the terminal.
- f = P** No effect.

* To preserve full software compatibility with its diagnostic programs and operating systems, Data General recommends that, at 600 baud, the model 6040 and 6041 terminal only be operated with a 4010 controller specially modified for this application.

The terminal is actually two devices; separate Busy and Done flags are available for input and for output operations.

Read Character

DIA [f] ac, TTI

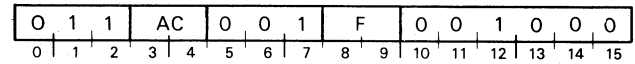

The contents of the receiver buffer are placed in bits 8-15 of the specified accumulator. Bits 0-7 are set to 0. After the transfer, the function specified by F is performed. The format of the specified AC is as follows:

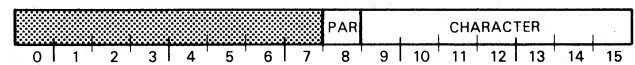

Bits	Name	Contents
0-7	---	Reserved for future use.
8	Parity	The value of the parity determined by the terminal.
9-15	Character	The character most recently received (right-justified).

Write Character

DOA [f] ac, TTO

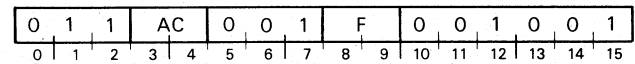

Bits 8-15 of the specified accumulator are placed in the transmitter buffer. After the transfer, the function specified by F is performed. The contents of the specified AC remain unchanged. The format of the specified AC is as follows:

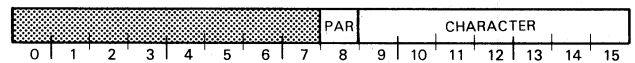

Bits	Name	Contents
0-7	---	Reserved for future use.
8	Parity	The value of parity is not tested at the terminal.
9-15	Character	The character to be transmitted (right-justified).

PROGRAMMING

The following discussion assumes that the terminal is interfaced with a Data General Basic I/O Controller in order to explain the I/O programming of the terminal, and therefore contains information specific to that controller. Since the data terminal is actually two separate devices, input and output are discussed separately.

Input

Striking any character key or a combination of CTRL or SHIFT with a character key transmits a serial data burst to the controller. This data burst is assembled into an eight bit parallel word and stored in the controller's input buffer. After the character is assembled in the controller, the Input Busy flag is set to 0, the Input Done flag is set to 1, and a program interrupt request is initiated.

The character can then be read by issuing a READ CHARACTER instruction (DIA). The Input Done flag should then be set to 0 with either a Start or a Clear command. This allows the next character to initiate a program interrupt request when it is fully assembled.

Output

A character is loaded into the output buffer of the controller by issuing a WRITE CHARACTER instruction (DOA). A Start command initiates a parallel to serial conversion and transmits the resulting data burst. While the character is being transmitted serially to the printer, the Output Busy flag is set to 1. Upon completion of the transmission, the Output Busy flag is set to 0 and the Output Done flag is set to 1, thus initiating a program interrupt request.

The 6040 and 6041 terminals return a program-transparent Terminal Busy flag to the controller. The signal can be used by specially modified controllers to freeze the controller's Output Busy flag and delay transmission of a character to the terminal when the terminal's input buffer is full. In the modified controllers, the transmission sequence proceeds as follows: The Start command sets the Output Busy flag to 1; when the Terminal Busy flag is zero, the controller initiates the parallel to serial conversion. Upon completion of the transmission, the Output Busy flag is set to 0 and the Output Done flag is set to 1, initiating a program interrupt request.

Each time a character is to be sent to the printer, the controller's output buffer must be reloaded with a WRITE CHARACTER instruction. A sequence of WRITE CHARACTER instructions together with Start commands is used to transmit a multi-character message. The program must allow each character to be transmitted before loading the next character into the output buffer.

TIMING CONSIDERATIONS

Input

After the controller's Input Done flag is set to 1, and before another key strike can destroy the character in the input buffer, the character is available for a READ CHARACTER BUFFER instruction for a time interval determined by the baud rate. The program must respond to the interrupt request and read the character within the time interval indicated in the following table to avoid possible data loss.

PROGRAMMED I/O LATENCY

Baud Rate	Max Allowable Programmed I/O Latency
110	21.59ms
150	15.84ms
300	7.92ms
600	3.95ms

Output

After the controller's Output Done flag is set to 1, the program should provide another character within a time period determined by the baud rate to keep the transmission line operating at its maximum rate.

MAXIMUM RATE TIME LIMITS

Baud Rate	Time Limit
110	9.15ms
150	6.64ms
300	3.33ms
600	1.66ms

Considerations for 600 Baud

At 600 baud, the time needed by the terminal to return its carriage to the left hand margin (Carriage Return) becomes significant. Data General intends that model 6040 and 6041 terminals be used at 600 baud only with controllers specially modified to test the (program-transparent) Terminal Busy flag returned by these units. But the terminals can operate with unmodified DGC asynchronous communications interfaces provided certain timing restrictions are met:

1. The program must not allow the output character stream to lead the terminal's (printer) activity by more than 40 characters.
2. The program must not allow the output character stream to trail the terminal's (printer) activity once the line begins to print.

Both of these constraints can be met relatively easily by padding the output stream with fill characters (e.g. the DEL character,) so that the terminal's input buffer never overflows--and never completely empties. (Fill characters are stored in the terminal's input buffer, but upon output from the buffer they are processed--i.e. ignored--more quickly than printable characters. Ideally, the program should send the full line of characters at the maximum data rate, and terminate the line by sending fill characters at least until the carriage return operation ends. The graph below estimates the minimum number of fill characters needed for various length carriage returns.

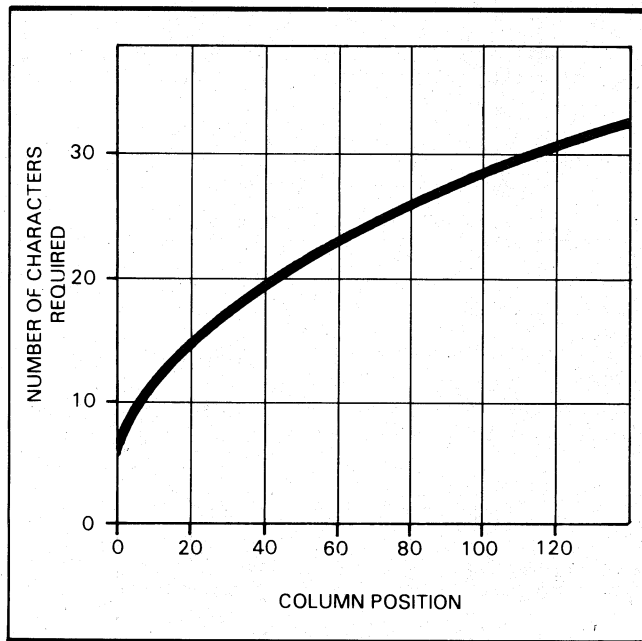

PROGRAMMING EXAMPLES

The following examples show how characters are passed between the computer, the printer, and the keyboard when interfaced with a Basic I/O Controller such as the 4010. The first example reads a character from the keyboard and the second example prints a character on the terminal.

EXAMPLE 1

Read a character from the keyboard

```
SKPDN   TTI       ;Character buffer loaded yet?
JMP     -1       ;No
DIAC    1,TTI    ;Read character and clear the
                    Done flag
```

EXAMPLE 2

Print a character

```
SKPBZ   TTO       ;terminal printer free?
JMP     -1       ;No, try again
DOAS    1,TTO    ;Print character
```

The subroutine shown in example 3 and called by a JUMP TO SUBROUTINE instruction JSR TTYRD, illustrates both reading and echoing characters on the terminal, with the printer's interrupts disabled. It uses AC0 to store the character.

EXAMPLE 3

Subroutine to read and echo characters (interrupts disabled)

```
TTYRD:  SKPDN   TTI       ;Has character been typed?
        JMP     -1       ;No, then wait
        DIAC    0,TTI    ;Yes, then read char, clear done
        SKPBZ   TTO       ;Is TTO ready?
        JMP     -1       ;No, Then wait
        DOAS    0,TTO    ;Yes, Then echo character
```

Peripherals are usually programmed using the program interrupt facility. This technique is necessary to avoid continually checking the condition of the device status flags. The program interrupt facility frees the processor to execute other tasks or to service other peripheral devices during the time the data terminal completes an operation or when it does not require processor intervention. The routine shown in example 4 will read a line and echo it on the printer using the interrupt priority structure. It will read characters into a buffer beginning at location 1000₈. It is terminated by either a carriage return or a line overflow. Line overflow is determined by the value of MAXLL, the maximum line length.

EXAMPLE 4

Read a line using interrupts

```

        .LOC 0
        0          ;PC goes here on interrupt
        IHAND      ; Address of interrupt handler
        .LOC 400
START:  LDA        1,BUFFR ;Set up buffer pointer in
        STA        1,23   ;auto-increment location 23
        LDA        1,MAXLL ;Get maximum line length
        STA        1,CNTR ;Initialize line overflow counter
        SUBZL     1,1     ;Set AC1 = 1
        DOBS      1,CPU   ;Maskout TTO, turn on interrupts
        ---
        ---           ;Program can do useful things
        ---           ;while line is being read
        ---
HANG:   LDA        0,CBTR ;When need full line to continue,
        MOV        0,0,SZR ;Hang up here until
        JMP        :-2    ;reading is all done
        ---
        ---
BUFFR:  777
MAXLL:  204
CNTR:   0
        ---
        ---
IHAND:  SKPDN     TTI     ;Make sure TTI interrupted
        HALT      ;Error--another device interrupted
        STA      0,SAVO  ;Save AC's that will be used
        STA      1,SAV1
        DIAC     0,TTI   ;Read character and clear Done
        STA      0,@23   ;Store character in buffer
        SKPBZ    TTO     ;Make sure TTO not busy
        JMP      :-1
        DOAS     0,TTO   ;Echo character
        LDA      1,CR    ;End of line?
        SUB      0,1,SZR
        JMP      .+4     ;No
        SUBC    0,0     ;Yes, clear ACO, preserve Carry
        STA      0,CNTR ;Zero out cntr to signal line done
        JMP      .+3
        DSZ     CNTR    ;If not a new line, decrement CNTR
        JMP     OUT     ;Line not yet done, go dismiss
        LDA     0,TTMSK ;Line is done
        MSKO    0       ;Maskout TTI/TTO to inhibit further
                        ;input
OUT:    LDA      0,SAVO  ;Restore accumulators
        LDA      1,SAV1
        INTEN   ;Turn interrupts back on
        JMP     @0      ;Return to interrupted program

SAVO:   0
SAV1:   0
CR:     015
TTMSK:  3
    
```

Data General Corporation (DGC) has prepared this manual for use by DGC personnel and customers as a guide to the proper installation, operation, and maintenance of DGC equipment and software. The drawings and specifications contained herein are the property of DGC and shall neither be reproduced in whole or in part without DGC's prior written approval nor be implied to grant any license to make, use, or sell equipment manufactured in accordance herewith.

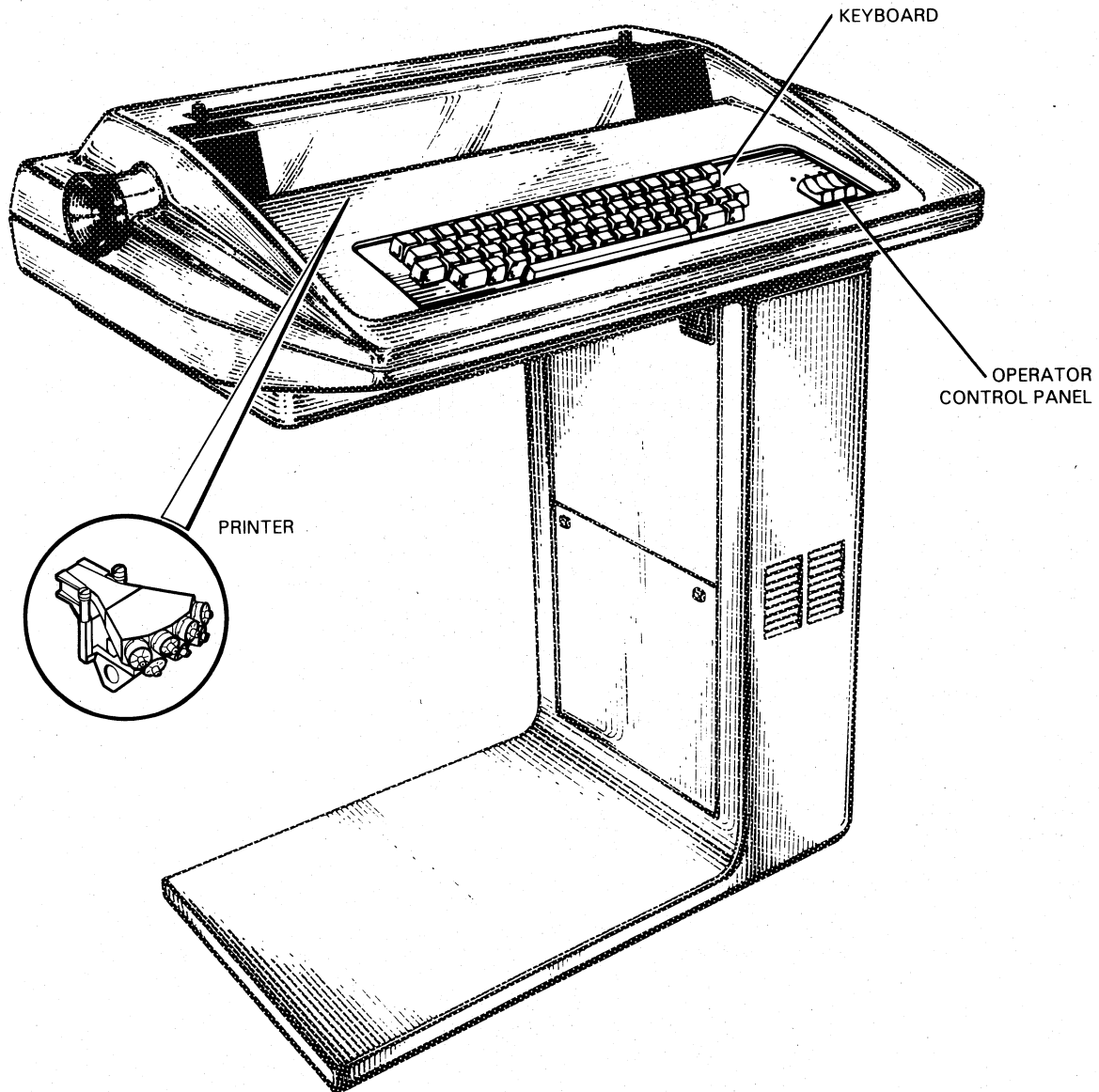

DG-02694

SECTION IV OPERATING CONTROLS AND PROCEDURES

INTRODUCTION

This section describes the operator controls on the 6040-6043 data terminals, and the procedures required to operate the unit. A brief description of the terminal and its operation is given to familiarize the operator with the unit. Maintenance is not included in this section; the reader is referred to Section V for these procedures.

Data General's 6040-6043 data terminals (*the model 6042 is pictured below*) are multiple baud rate data terminals which produce 132-column hard copy output on industry standard, pin-feed paper. Models 6040 and 6042 are full duplex send/receive units with keyboards. Models 6041 and 6043 are receive-only terminals, and have no keyboard.

All models print 124 distinct 5x7 dot matrix characters, available in six distinct character sets that provide the basic alphabet with numbers plus common usage symbols for applications in the United States and five other regions throughout the world. (*See Appendix B.*) A terminal can be set up to print 124 characters or it may be restricted to printing one of two character subsets by field-installed hardware jumpers. One jumper configuration (64 characters) limits the printer to upper case characters, numbers, punctuation marks, the space character, and certain symbols such as parentheses, and square brackets. In this configuration, the terminal performs "character foldover:" it converts lower case character codes (plus six other codes) to the upper case equivalent before printing. (*See Appendix B for details.*) In the second configuration (95 characters), foldover is disabled and the terminal prints lower case characters and six other characters in addition to the basic teletypewriter set.

A 60 key, three level typewriter paired keyboard is an integral part of the 6040/6042 terminal, and provides data entry to the computer system. All 128 ASCII characters may be generated from the keyboard.

Rocker switches and indicator lights on a control panel adjacent to the keyboard are used for operator functions.

An audible "carriage-right" tone sounds when the printhead reaches character position 126, to signal the operator that the end of the current line is approaching. If data is entered after the carriage contacts the right hand stop, the printhead will overprint the characters.

A "view print" feature is standard on all models, and moves the printhead clear of the printed text to allow the operator to view the text, including the last character printed. When a lapse of 1.2 seconds occurs during data transmission to the printhead, the printhead automatically moves six character positions to the right, giving a view of the last character printed. When data transmission resumes, the printhead returns to the character position following the last character printed. This operation takes place during both on- and off-line operation; the "view print" feature may be disabled with the VIEW ON/VIEW OFF switch on the operator's control panel, as described under "Operating Controls" below.

NOTE *When the printhead is near the right margin and after the "carriage-right" tone has sounded (approximately character position 126), the printhead moves six character positions to the left after a 1.2 second lapse in data transmission.*

The data terminals are available with six styles of printable characters, as depicted in Appendix B. Three subsets of the 128 symbols in a complete character set can be selected by field-installable jumpers. The subsets are upper case only ("foldover"), upper/lower case, and upper/lower case plus ASCII "control" code symbols.

When upper-case characters only are selected, the print mechanism will translate any lower-case alpha code to its upper case equivalent. Lower case alpha characters are not printed with this choice of characters. When upper/lower case is selected, all alpha characters print without translation; in the final mode, standard ASCII symbols are printed to represent control codes (except CR, BEL, LF & DEL) received by the terminal.

KEYBOARD (Models 6040, 6042)

The keyboard contains 60 keys which may be used singly or in combination to generate all 128 ASCII character codes. The character codes are 3-digit octal numbers ranging from 000₈ to 177₈ inclusive. A unique character is assigned to each octal number, in accordance with a standard coding scheme (ASCII). Appendix B lists all 128 ASCII codes in octal and hexadecimal notation, together with the character or symbol assigned to each code.

Keytop legends vary slightly among terminal options, corresponding to variations in the printed characters. ASCII code is used on all models. Each export model may be selected to print one of the three subsets of ASCII characters.

The keyboard operates on-line or off-line with the computer, as selected by a switch on the operator's control panel, described under "Operator Controls" below. When the terminal is off-line, a character code generated at the keyboard is transmitted directly to the printhead and the character is printed if the character set contains that character. The character code is not transferred to the computer, and the printer functions somewhat like a standard typewriter. When the terminal is on-line, the character code generated at the keyboard is transferred to the controller for processing. If the computer contains an "echo" program, it transfers the character code back to the printer and the character is printed, provided the selected set in the printer contains that character; when the terminal operates with an "echo" program, the sequence of events is as follows:

1. The character code is transferred from the keyboard to the computer system.
2. The code is returned to the printer, where it is decoded by the printhead logic.
3. The printhead prints the character (if the character is contained in the printable subset of characters).

The echo sequence is completed so fast that the character is printed almost immediately. The time

delay is nearly imperceptible, and the printer appears to function as a standard typewriter.

There are 11 function keys on the keyboard, in addition to the alpha-numeric keys. Two of these function keys, SHIFT and ALPHA LOCK, perform functions as they do on a standard typewriter when the terminal operates off-line or when it operates on-line and the computer contains an echo program. Two more of these keys, RETURN and RPT, perform typewriter-like functions when the terminal is off-line or operating under an echo program. An additional four function keys, TAB, BS, ESC, and DEL, generate special control characters whose functions are defined by the computer program. The remaining two function keys, CTRL and BRK, are used for special functions as described in the table below. Operation of the function keys is tabulated below.

Keys	Function
SHIFT and any alpha-numeric key.	Generates upper-case character code for the alpha-numeric key depressed.
ALPHA LOCK and any alpha key.	Generates upper case character code for the alpha key depressed. Numeric characters are not affected. The ALPHA LOCK function remains asserted until the ALPHA LOCK key is depressed again. An indicator light on the SHIFT key glows when this function is asserted.
CR (Carriage Return)	The printhead returns to the leftmost character position. The paper does not advance.
LINE FEED	The paper advances one line.
RPT (Repeat) and any key.	Repeatedly generates the character code for the depressed key. Stops when one or both keys are released.
TAB	Generates character code 011 ₈ . No effect during off-line operation. The computer program may define a tab function during on-line operation, by inserting a number of spaces.
BS (Backspace)	Generates character code 010 ₈ . No effect during off-line operation. The computer program defines the function during on-line operation. The printhead does not move back to the last character position.
CTRL (Control) and any of 31 alpha-numeric keys.	Generates the control code corresponding to the alpha-numeric key depressed. The mnemonic and octal number for each control character is given at each key position.
ESC (Escape)	Generates control code 033 ₈ .
BRK (Break)	Generates a spacing line. No ASCII code is generated by this key.
DEL (Delete)	Generates control code 177 ₈ .

Data General Corporation (DGC) has prepared this manual for use by DGC personnel and customers as a guide to the proper installation, operation, and maintenance of DGC equipment and software. The drawings and specifications contained herein are the property of DGC and shall neither be reproduced in whole or in part without DGC's prior written approval nor be implied to grant any license to make, use, or sell equipment manufactured in accordance herewith.

TAB 011	061	062	063	064	065	066	067	070	071	NUM	000	US	037	075	RS	036	BS	010	BRK										
.	041	@	100	#	043	\$	044	%	045	^	046	&	047	*	052	(050)	051	—	137	+	053	~	176	012	DEL	177	
1	061	2	062	3	063	4	064	5	065	6	066	7	067	8	070	9	071	0	060	-	055	=	075	/	140	RETURN	015		
ESC	DCI	021	ETB	027	ENG	005	DC2	022	DC4	024	EM	031	NAK	025	HT	011	SI	017	DLE	020	ESC	033	FS	034					
033	033	Q	121	W	127	E	105	R	122	T	124	Y	131	U	125	I	111	O	117	P	120	I	135	!	174				
033	q	161	w	167	e	145	r	162	l	164	y	171	u	165	i	151	o	157	p	160	!	133	\	134					
CTRL	SOH	001	DC3	023	EOT	004	ACK	006	BEL	007	BS	010	LF	012	VT	013	FF	014		073		047	GS	035					
ALPHA LOCK	A	101	S	123	D	104	F	106	G	107	H	110	J	112	K	113	L	114	:	072	;	042	J	175	LINE FEED	012			
	a	141	s	163	d	144	f	146	g	147	h	150	j	152	k	153	l	154	:	073	;	047	I	173					
SHIFT	SUB	032	CAN	030	ETX	003	SYN	026	STX	002	SO	016	CR	015		054		056		057					SHIFT				
	Z	132	X	130	C	103	V	126	B	102	N	116	M	115	.	074	>	076	>	077					RPT				
	z	172	x	170	c	143	v	166	b	142	n	156	m	155	/	054	*	056	/	057									
	SPACE																			040									

LEGEND

CONTROL
SHIFTED
UNSHIFTED

7 BIT OCTAL OUTPUT CODE

DG-02798

OPERATOR CONTROLS

POWER SWITCH

A two-position switch is located on the inner side of the pedestal, and turns line power on or off to the power supply. Operation is as follows:

Position	Function
ON	The power supply is turned on, the fan runs, the READY light glows, and the printhead returns to the left margin.
OFF	The power supply and READY light are turned off.

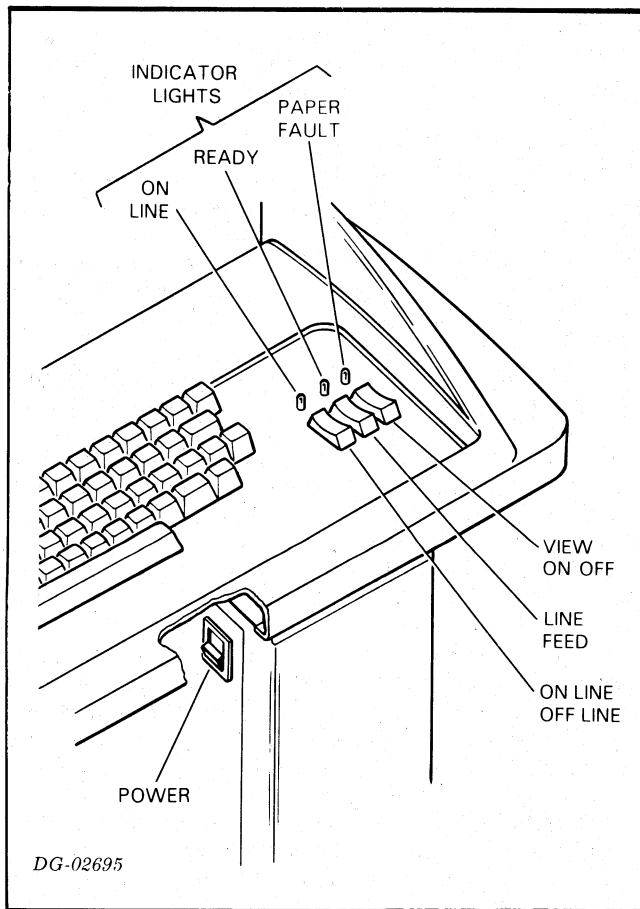

ON LINE/OFF LINE Switch and Indicator Light

A two-position rocker switch and an ON LINE indicator light are located on the operator's control panel. The switch is used to place the terminal on- or off-line with the computer, and the light displays the selected state. Operation is as follows:

Position	Function
ON LINE	The printer is placed on-line with the computer. The ON LINE indicator light glows.
OFF LINE	The terminal is off-line from the computer. Information entered at the keyboard is printed, but not transmitted to the computer. The ON LINE indicator light is off. Do NOT change this switch setting when the printer is receiving data from the computer, or data may be lost.

LINE FEED Switch

A three position rocker switch located on the operator's control panel is used to advance the paper. Depressing this switch backwards toward the rear of the terminal advances the paper one line each time the switch is pressed. Pressing (and holding) the switch forward toward the front of the terminals causes the paper to continuously feed. The LINE FEED switch operates when the terminal is on- or off- line with the computer.

VIEW ON/VIEW OFF Switch

A two-position rocker switch is located on the operator's control panel, and disables the automatic view feature. Operation is as follows:

Position	Function
VIEW ON	The automatic view feature functions normally.
VIEW OFF	The automatic view feature is disabled; the printhead will not move clear of the print during lapses in data transmission.

READY and PAPER FAULT Indicator Lights

These indicator lights are located on the operator's control panel and indicate status information as follows:

Indicator	Meaning When Glowing
READY	No faults or interlocks are set to disable operation. The terminal operates normally.
PAPER FAULT	The terminal has no more paper available. The current line will be printed up to and including the next carriage return, and the printer will stop. Data transmitted after this point will be lost. The terminal automatically goes off-line when it stops after a paper fault.

RIBBON ADVANCE, BAUD RATE Switches

A toggle switch labelled RIBBON ADVANCE is located under the top cover on the right-hand side as shown, and is used to wind the ribbon onto the spool, in the direction that the ribbon last moved. This function is always enabled, whether or not the terminal is on line.

A toggle switch labelled BAUD RATE is located under the top cover on the right-hand side as shown, and is used to select one of two or three baud rates for the device. The selected baud rate MUST agree with the controller's baud rate. Change this switch setting only when the terminal is off-line (ON LINE indicator light off).

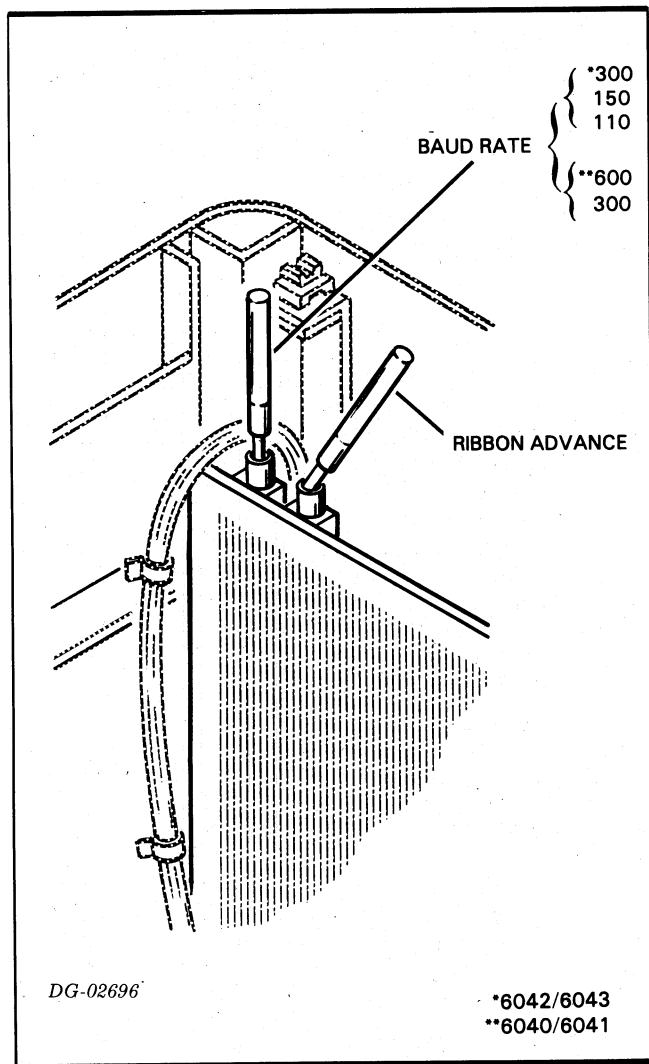

OPERATING PROCEDURES

Loading Paper

The 6040-6043 data terminals use industry standard pin-feed paper, single or multiple form (up to six-part forms), of any width between 4" and 15". A platen space lever may be set for single or multiple form, and the pin-feed tractors are easily adjustable to the desired paper width. The tractors may be moved to locate the paper at any desired platen position, allowing flexibility in locating the left margin. Typically, the paper is placed at the extreme left-hand position, and the left margin is at the "carriage home" printhead position. However, a programmer may choose to place the left margin to the right of the "carriage home" position, and the paper may be moved to accommodate such a shift.

Load the paper as follows:

- Place the terminal off-line by switching the ON LINE/OFF LINE switch to the OFF LINE position, so that the ON LINE indicator light is off. Turn the POWER switch OFF.
- Swing the top cover up until it latches open.
- Place the left-hand tractor at the position required for the desired left margin. The tractor may be moved by releasing the locking knob, moving the tractor to the desired position, and tightening the knob as shown in the figure.

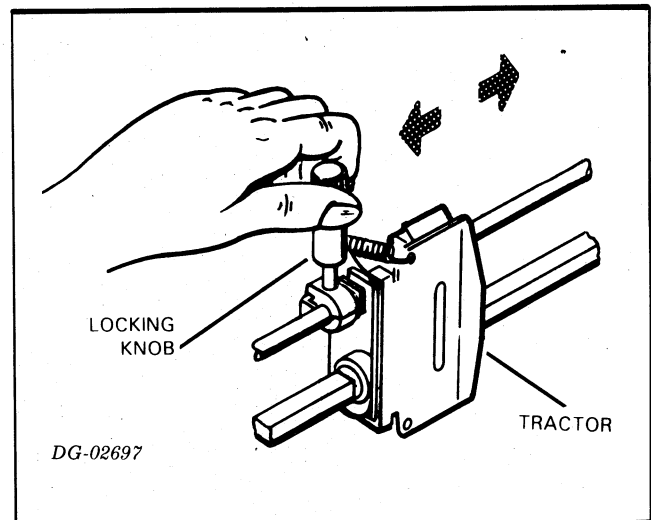

- Place a box of pin-feed paper under the terminal just behind the platen position, as shown in the figure.
- Move the printhead space lever to the widest (rearmost) position. This provides the spacing necessary to slide the paper into place, with no interference from the printhead or the leaf spring.

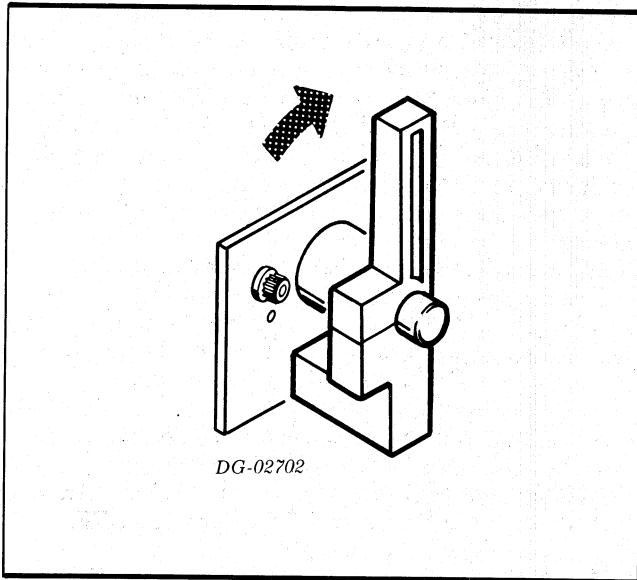

- Swing open the tractor doors, as shown in the figure. The right-hand tractor may need to be moved to a different position if a different width paper is used. This is most readily performed with the paper in position on the left-hand tractor pins, as described in the next step.

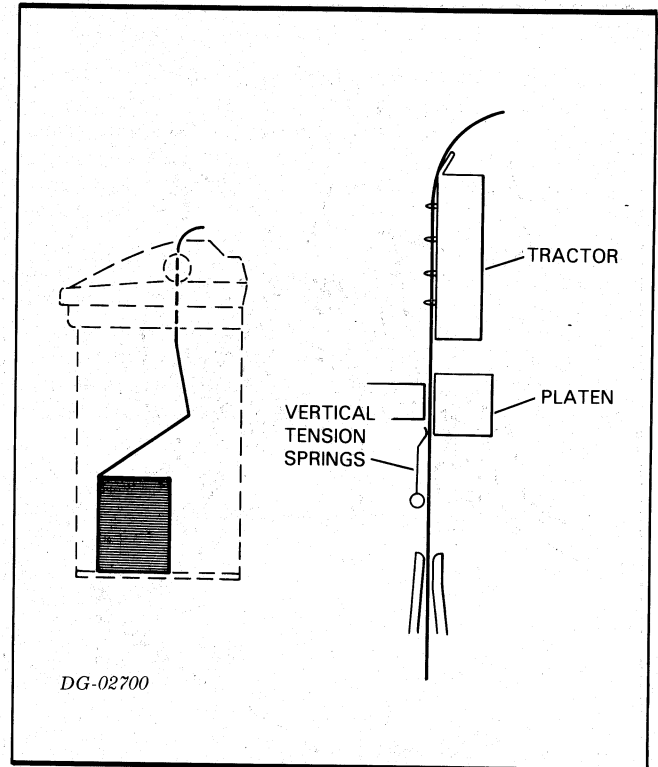
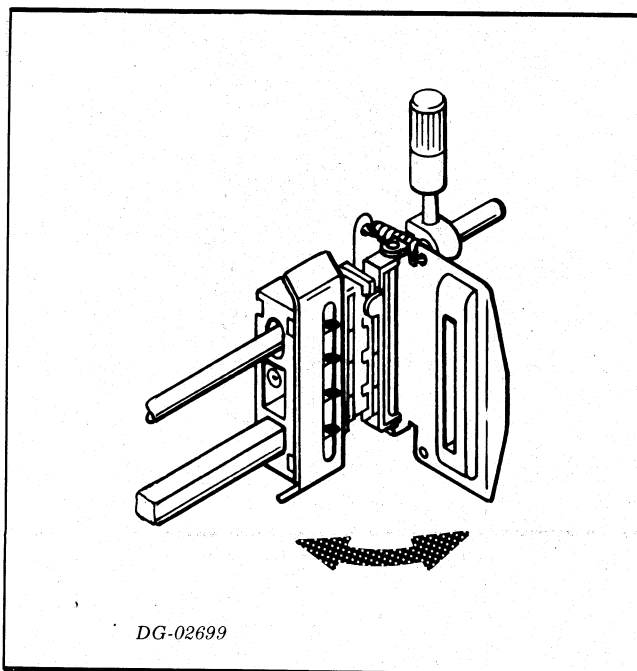

- Thread the leading edge of the paper through the bottom of the printer, under the leaf spring and into the left-hand tractor pins. Reposition the right-hand tractor as necessary, after locating the feed holes on the tractor pins.

CAUTION *Ensure that corresponding holes are engaged, so that the top of the paper is horizontal, or the paper will jam and tear.*

- Move the right-hand tractor slightly to the right to put a light horizontal tension on the paper. Be sure that the feed holes are not deformed by this tension, or the paper may tear and/or jam in the tractor.
- Close the tractor doors, and recheck that the edge of the paper is parallel to the platen.
- Turn the power switch ON.
- Adjust the paper to the desired vertical position using the LINE FEED switch. Make fine adjustments manually by pulling out the form feed vernier knob and rotating it.

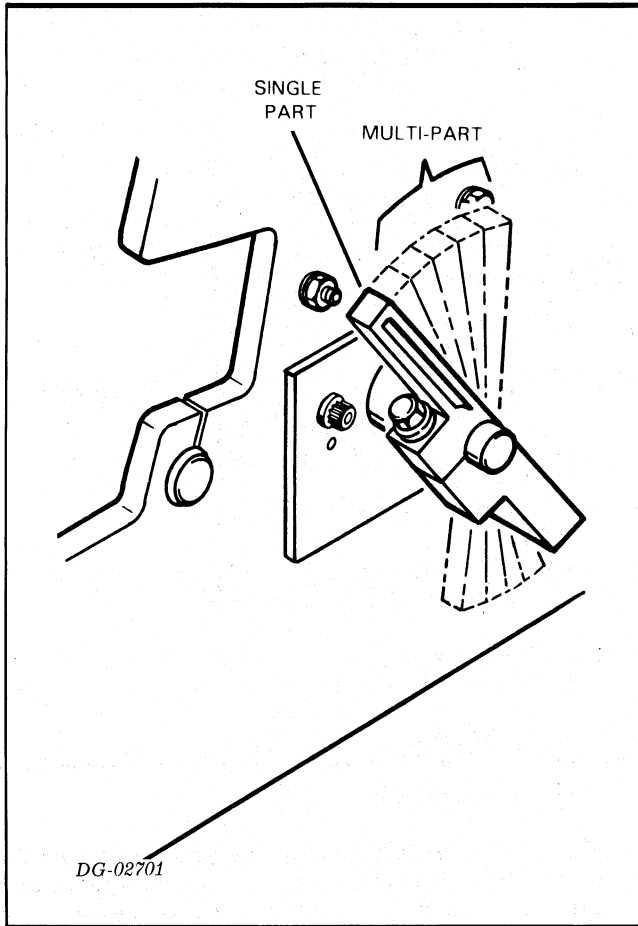

- Move the printhead space lever to the desired detent position for the form thickness used: forward for single paper, detents 2 through 6 for multi-part forms (up to six-part maximum).

NOTE The numbering of the detent positions corresponds approximately to the number of forms. However, form thickness varies among suppliers; adjust the platen lever experimentally to obtain the desired print contrast.

- Release the top cover latches and close the cover. The paper should feed over the top rear of the cover.
- Recheck that the paper path agrees with the figure, turn the POWER switch ON, and place the ON LINE/OFF LINE switch in the desired operating position.

Changing the Ribbon

The printhead uses the upper half of the ribbon when printing. When the ribbon is exhausted on the first half, wind the ribbon, remove it, and replace it upside down to use the second half of the ribbon. When this half is exhausted, replace the ribbon. The procedures for both operations are nearly identical, and are described below.

NOTE When the ribbon is inverted or replaced, clean the printhead to remove ink and paper dust. This will maintain print clarity and extend printhead service. The cleaning procedure is included in the step-by-step procedure below.

Proceed to change the ribbon as follows:

- Place the terminal off-line by setting the ON LINE/OFF LINE switch to the OFF LINE position, so that the ON LINE indicator light is off.
- Swing the top cover up until it latches open.
- Rewind the ribbon using the Ribbon Advance toggle switch. Turn the POWER switch OFF.
- Move the platen away from the printhead by moving the printhead space lever to the rearmost position, as shown on the figure.
- Remove the paper from the terminal.

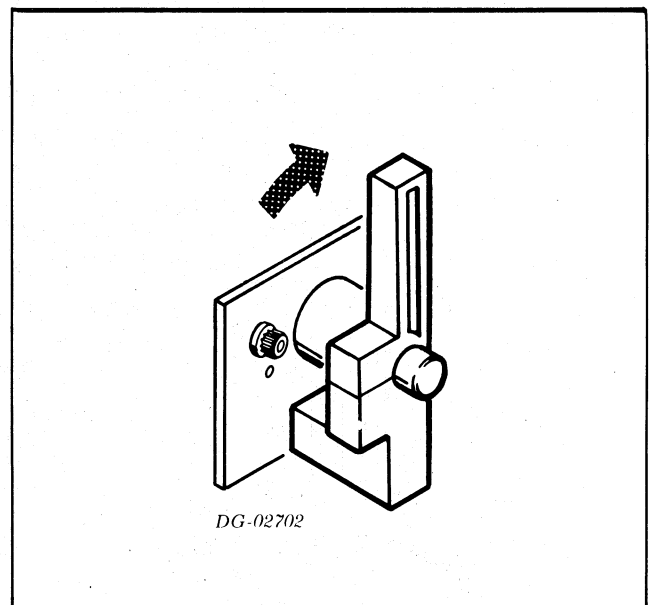

Data General Corporation (DGC) has prepared this manual for use by DGC personnel and customers as a guide to the proper installation, operation, and maintenance of DGC equipment and software. The drawings and specifications contained herein are the property of DGC and shall neither be reproduced in whole or in part without DGC's prior written approval nor be implied to grant any license to make, use, or sell equipment manufactured in accordance herewith.

- Lift the ribbon spools off their spindles and remove the ribbon from its various guides.
- Clean the printhead face with a lint-free tissue. Fold the tissue and wipe the printhead as shown. Repeat with clean tissues until the face is clean. Wipe the platen with a clean tissue.

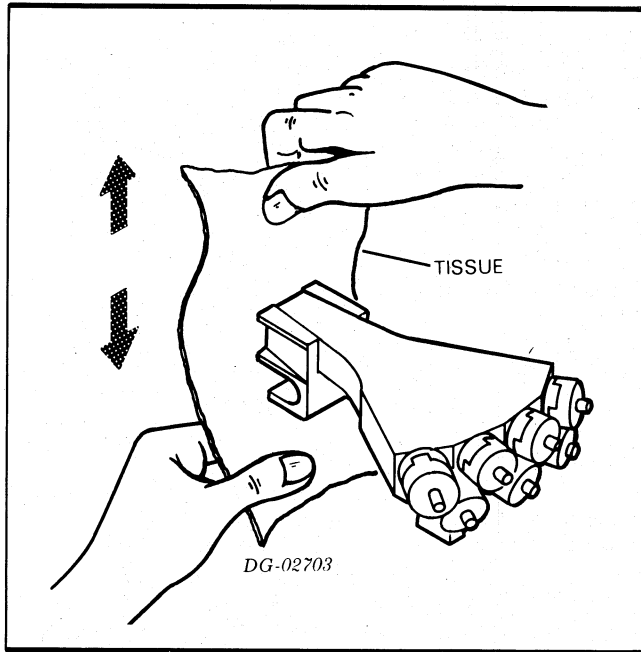

- Place the full spool of new (or inverted) ribbon on one of the ribbon spindles. Two pins on the spool holder should engage with holes in the spool.
- Unwind some ribbon from the full spool, thread the ribbon through the ribbon guides and switches, and place the empty spool on the other spindle. The correct ribbon path is shown in the illustration, and must be followed exactly. The ribbon path is also marked on the terminal.

NOTE There is an "end-of-ribbon" rivet near the end of the ribbon; this rivet **MUST** be between the empty spool and the "end-of-ribbon" switch, as shown.

- Apply a slight tension to the ribbon by taking up any slack with the empty spool.
- Replace the paper and set the platen lever to the desired operating position.
- Recheck the ribbon path, and close the top cover.
- Turn the POWER switch ON.
- Place the ON LINE/OFF LINE switch in the desired operating position.

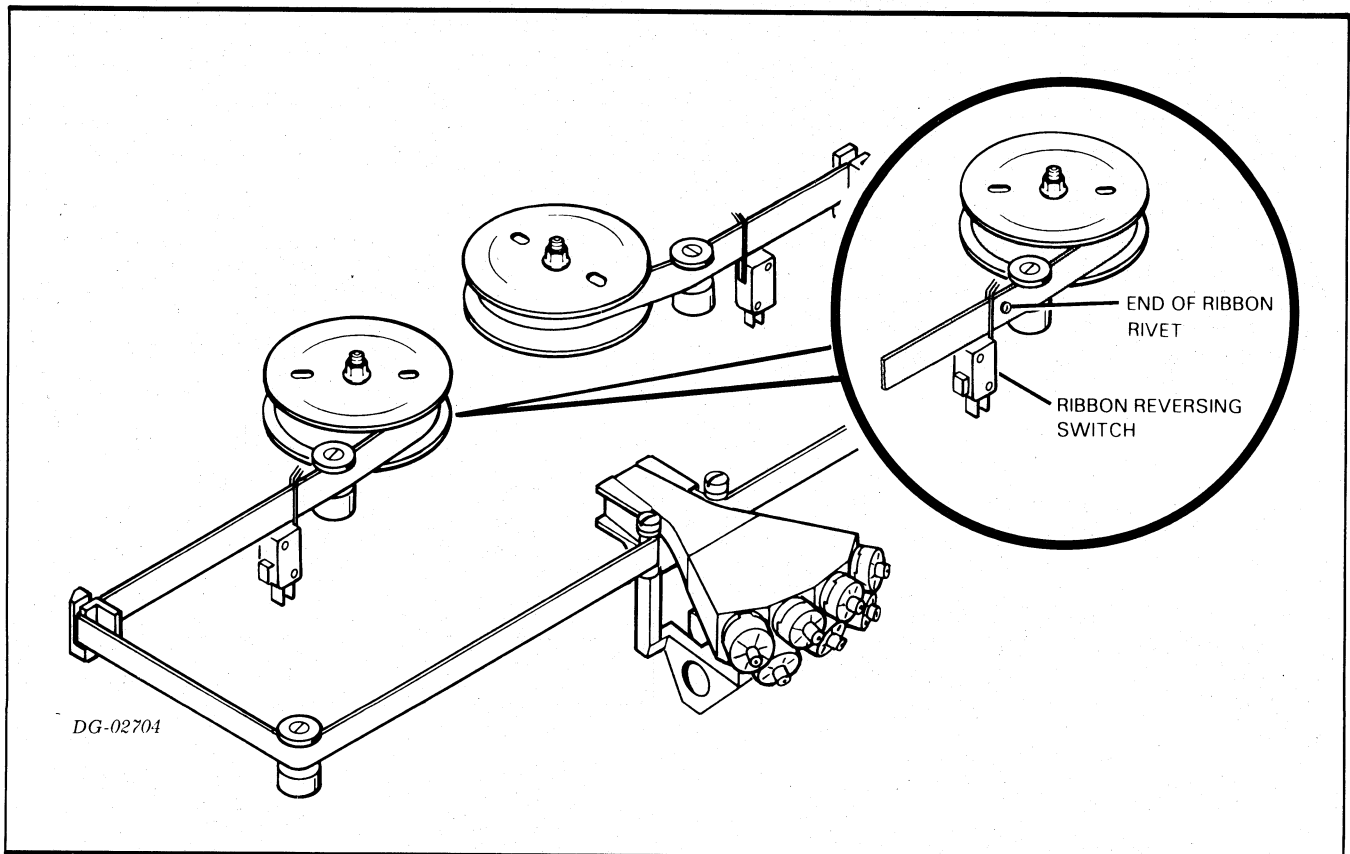

OPERATOR PRECAUTIONS

Take care that foreign objects such as paper clips or thumbtacks do not fall into the printer mechanism. If an object does fall into the mechanism, turn the POWER switch to OFF, unplug the power cord from the wall outlet, and retrieve the object.

The paper used should conform to the specifications given in Appendix A. In particular, form crimps must be tab-type only; metal fasteners or glue spots should not be used or the print mechanism may be damaged.

Do not use the keyboard area as a tray for coffee cups, ash trays, food, etc.

Keep the top cover closed except when changing the ribbon or the paper.

Support the paper on the top cover when separating forms, to prevent damaging the pin-feed holes which could cause paper jamming.

Ensure that the paper feeds over the top and back of the terminal.

Clean the terminal using a lint-free tissue; if necessary, use a mild detergent sparingly.

This page intentionally left blank.

SECTION V

THEORY OF OPERATION

INTRODUCTION

This section describes the operating principals of key assemblies and electromechanical subsystems in the 6042 and 6043 data terminals. They are designed in a series of subsystems organized around well defined primitives or functional operations; the segments of this section are largely organized around these same operations, hence most segments describe a complete functional subsystem. Information is presented in summary form with the aid of block diagrams, flow charts, and generalized timing diagrams.

BLOCK DIAGRAM OF THE DATA TERMINAL

The block diagram on the next page shows the principal components plus the control and data paths of the 6040 data terminals. Data and most command signals which are TTL levels, and whose circuits generally employ standard digital IC's are shown as single line or bussed paths with signal names. Control paths that employ non-TTL digital signals (e.g. stepping motor pulses) are shown as twisted-pair or two wire paths.

Data General Corporation (DGC) has prepared this manual for use by DGC personnel and customers as a guide to the proper installation, operation, and maintenance of DGC equipment and software. The drawings and specifications contained herein are the property of DGC and shall neither be reproduced in whole or in part without DGC's prior written approval nor be implied to grant any license to make, use, or sell equipment manufactured in accordance herewith.

This page intentionally left blank.

DATA GENERAL'S 6042 DATA TERMINALS are organized as shown in this diagram. When the terminal is on-line, it appears as two separate devices to the computer system. The input (TO computer) section comprises the keyboard and interface transmitter; the output (FROM computer) section comprises the interface receiver, the character buffer and the printer system. The 6043 receive-only terminals comprise only the output section of this diagram. All data transfer with the computer system takes place through the serial I/O paths representing the device cable conductors.

A bit-serial data burst containing a character from the computer system is shifted into parallel form as it enters the interface; when a stop bit is detected, the character is moved in bit-parallel fashion into the character buffer and then transferred to the character generator. The action taken by the printer system depends on the character code. If the code represents a printable character, the applicable printhead solenoids as well as the printhead position control are activated and the character is printed slice-by-slice. If the code is a control character, the position control or the paper feed control is enabled, or an audible tone (Bell) is sounded in response to the control code.

Depressing a key on the terminal initiates data transfer to the computer. A 7-bit code corresponding to the depressed key is loaded in bit-parallel form into the interface where Start, Stop and Parity bits are added to it. After the character is assembled, it is shifted in bit-serial fashion onto the I/O line and transferred to the computer system.

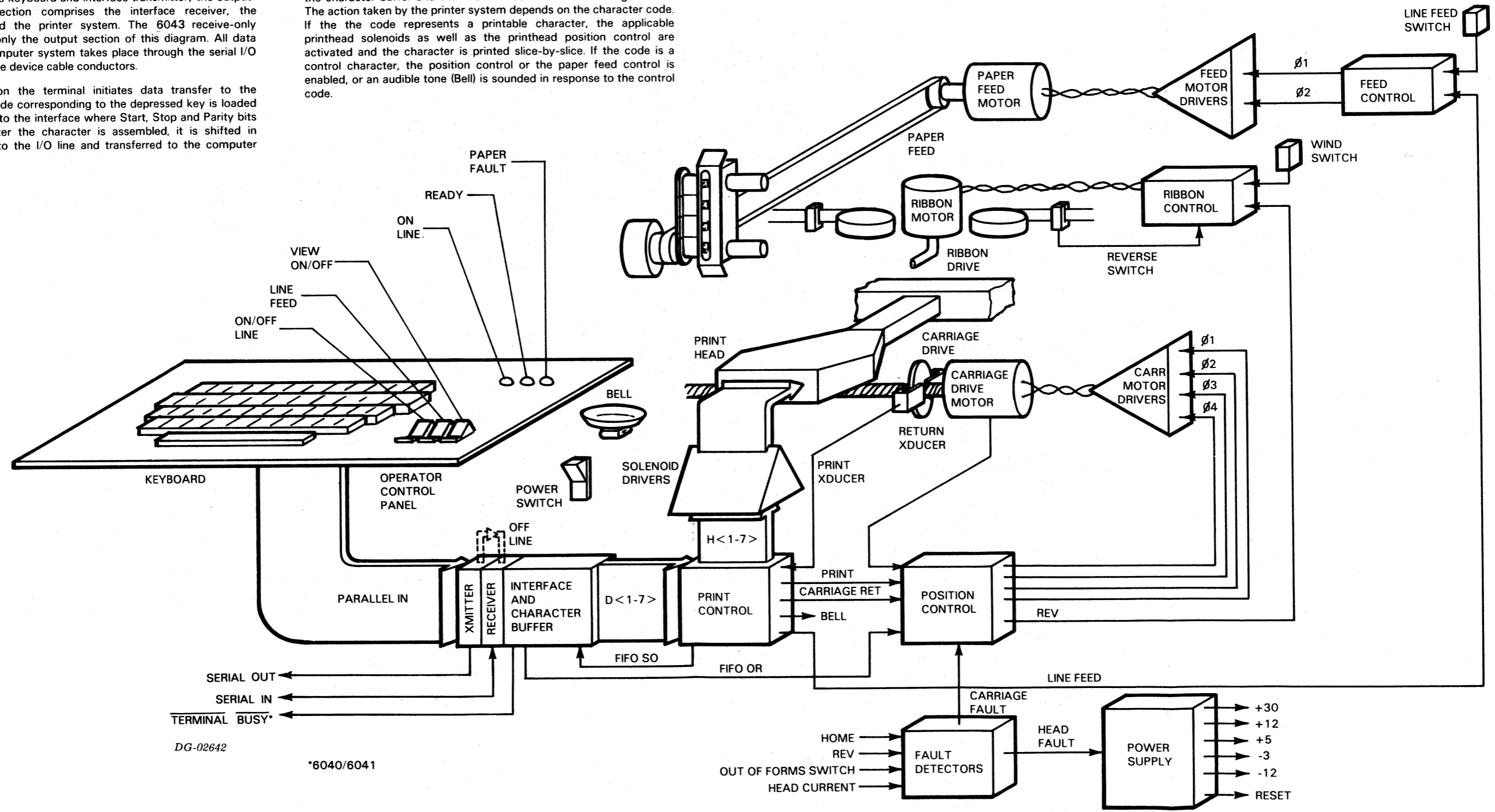

DG-02642

*6040/6041



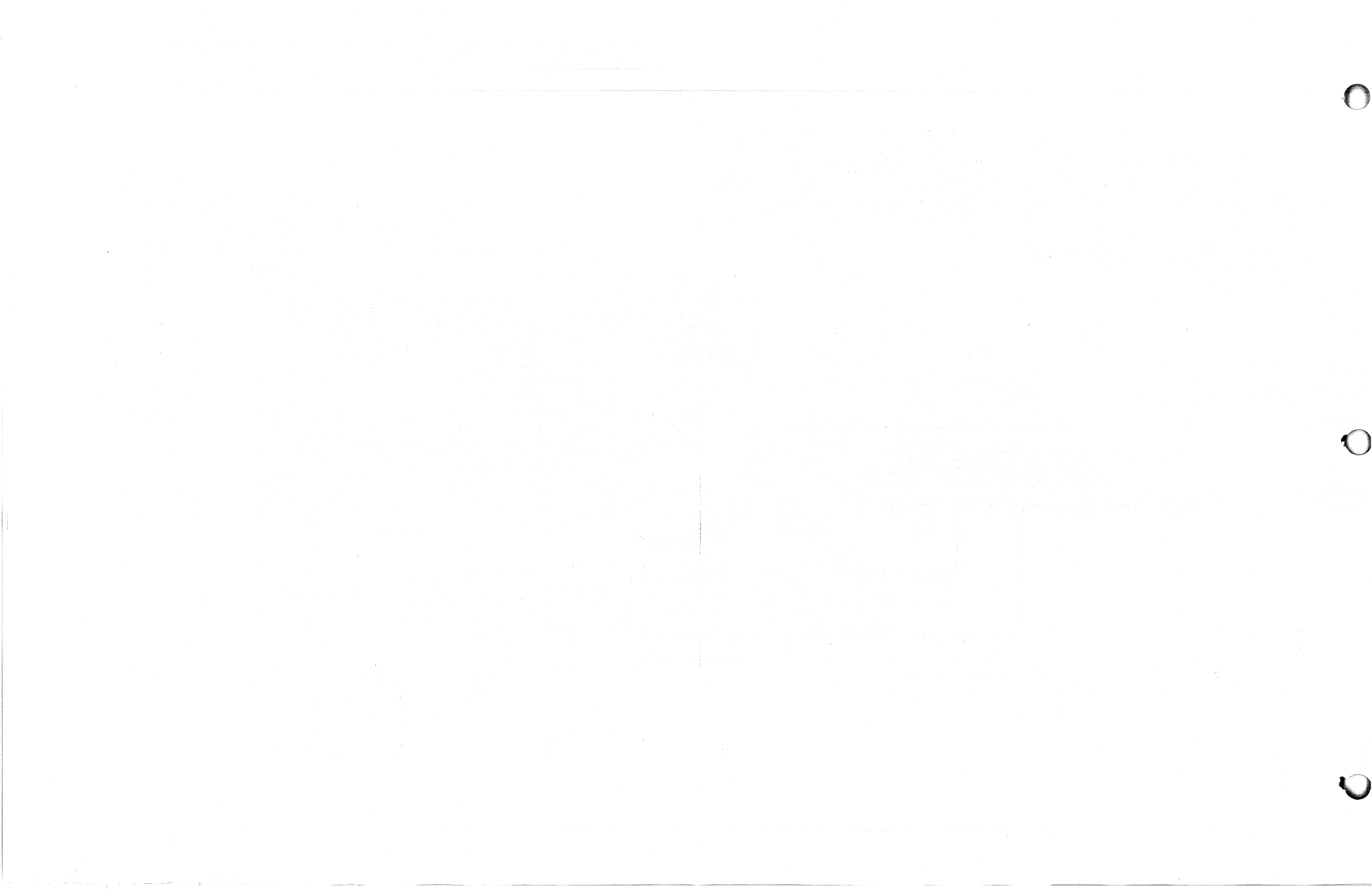

INTERFACE AND CHARACTER BUFFER

The interface and character buffer transmits, receives, and stores data, interacting with the controller to pass characters among the controller, the printer, and the keyboard. The interface and character buffer operates in two modes: on-line and off-line. On-line, data passes via a 20mA current loop or an EIA interface from the controller to the printer and from the keyboard to the controller. Off-line, data passes from the keyboard to the printer. The interface and character buffer consists of a universal asynchronous Receiver/Transmitter (UART), a 40 character First In- First Out (FIFO) buffer, and a timing circuit to establish the baud rate, and in the 6040 and 6041 terminals, a Terminal Busy flag which sends the status of the FIFO buffer to the controller via a 20ma current loop.

The data transferred between the terminal and the controller is formatted as shown in the following diagram. These asynchronous data bursts consist of a start bit, a 7-bit ASCII character code, a parity bit, and one or two stop bits depending on the baud rate selected.

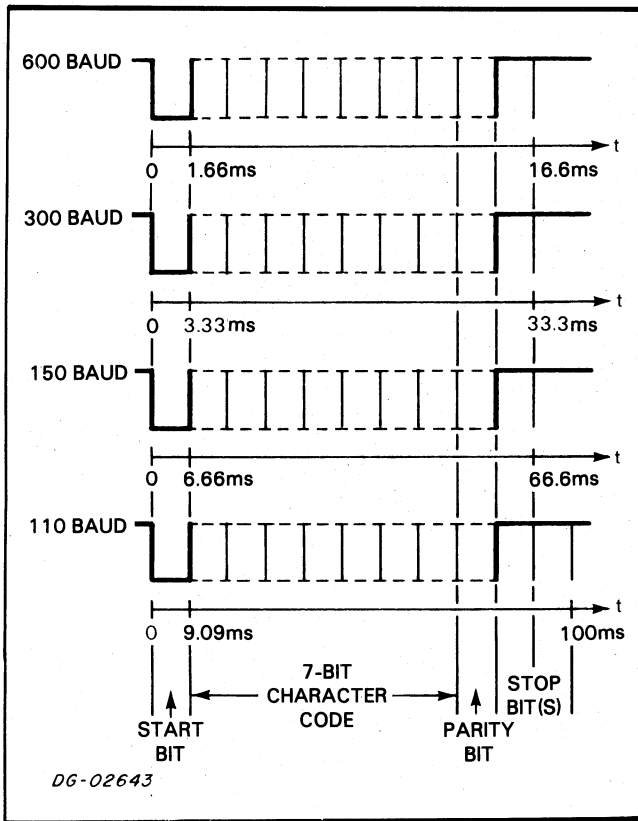

Receiver Transmitter (UART)

The UART is a 40 pin large scale integrated (LSI) circuit containing both a receiver and a transmitter which operate independently of each other. The receiver receives serial data bursts and converts them into 7-bit parallel characters which are loaded into the FIFO buffer. The transmitter receives 7-bit parallel character codes from the keyboard and converts them into serial data bursts. The timing of the data transfer rate is established by a clock running at 16 times the desired baud rate. The times 16 (X16) clock is common to the receiver and the transmitter; the input and the output baud rates are always equal.

When the terminal operates on-line, the receiver input is the serial data bursts from the interface and the transmitter output is the serial data bursts to the interface. Off-line, the receiver input is the transmitter output.

The receiver begins data reception when a start bit is received and verified. After verification of a start pulse the input level is sampled every 16 clock pulses and each sampled bit is loaded into the receiver shift register. Detection of the stop bit terminates the reception. The stop bit loads the contents of the shift register into the output data register. After the data register is loaded, the signal DATA AVAILABLE asserts, indicating that the character is available to the FIFO buffer.

The transmitter input register is parallel loaded with a character from the keyboard upon detection of a data strobe pulse. The keyboard generates DATA STROBE pulse on each keystrike. When the Repeat and another key are depressed the keyboard asserts the low level signal RPT, which causes the interface logic to repeatedly generate data strobe pulses. Start, stop, and parity bits and the contents of the input register are loaded into the transmitter shift register for transmission. The register shifts a bit to the output line every 16 clock pulses. Transmission is terminated when the last stop bit has been on the output line for one bit time.

Character Buffer (FIFO)

The character buffer is an integrated circuit that can stack up to 40 character codes in an ordered (FIFO) queue. It is contained in a 28 pin package. It buffers the flow of characters between the input interface and the character printer when certain control sequences (e.g. Carriage return) briefly suspend the operation of the printhead.

The FIFO buffer can stack up to 40 characters in a queue. Characters leave the buffer in the order that

they arrive; the first character into the buffer is the first character out of the buffer.

A character is shifted into the input cell of the FIFO buffer by the FIFO shift-in signal, **FIFO SI**. After the character is loaded into the input cell, the character shifts down through the buffer, toward the FIFO's output cell, to the first empty cell closest to the output. While the character is in the FIFO's input cell, the input ready signal, **FIFO IR**, goes false, indicating the input cell is occupied and not ready to receive

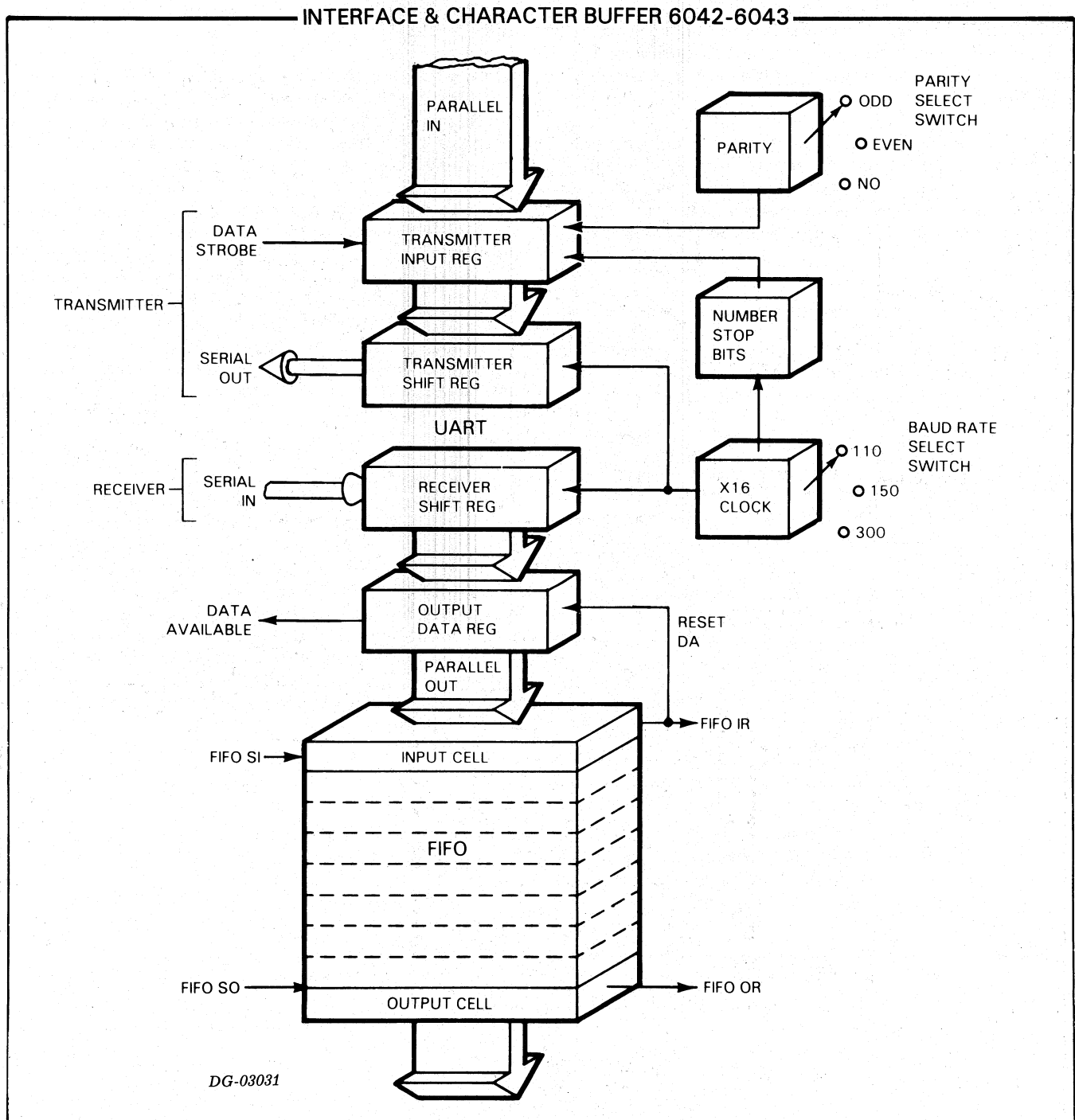

another character. When the character falls out of the input cell and into the FIFO stack, **FIFO IR**, is asserted. If the FIFO buffer is empty, a character received at the input essentially falls through to the output cell. If the buffer contains a character, the received character stacks up on top of the previously received character. Successive characters stack up on top of the former ones in the order that they arrive. Characters shift out of the buffer from the bottom of the stack. When a character shifts out of the output cell all characters in the buffer shift down one cell toward the output. The

shifting of characters out of the output cell is controlled by the FIFO shift-out signal, **FIFO SO**.

The buffer informs the position control of its status with the FIFO output ready signal, **FIFO OR**. When the buffer is empty, this signal is low; when the buffer contains characters, **FIFO OR** is high. The position control uses this information for catch-up mode operation.

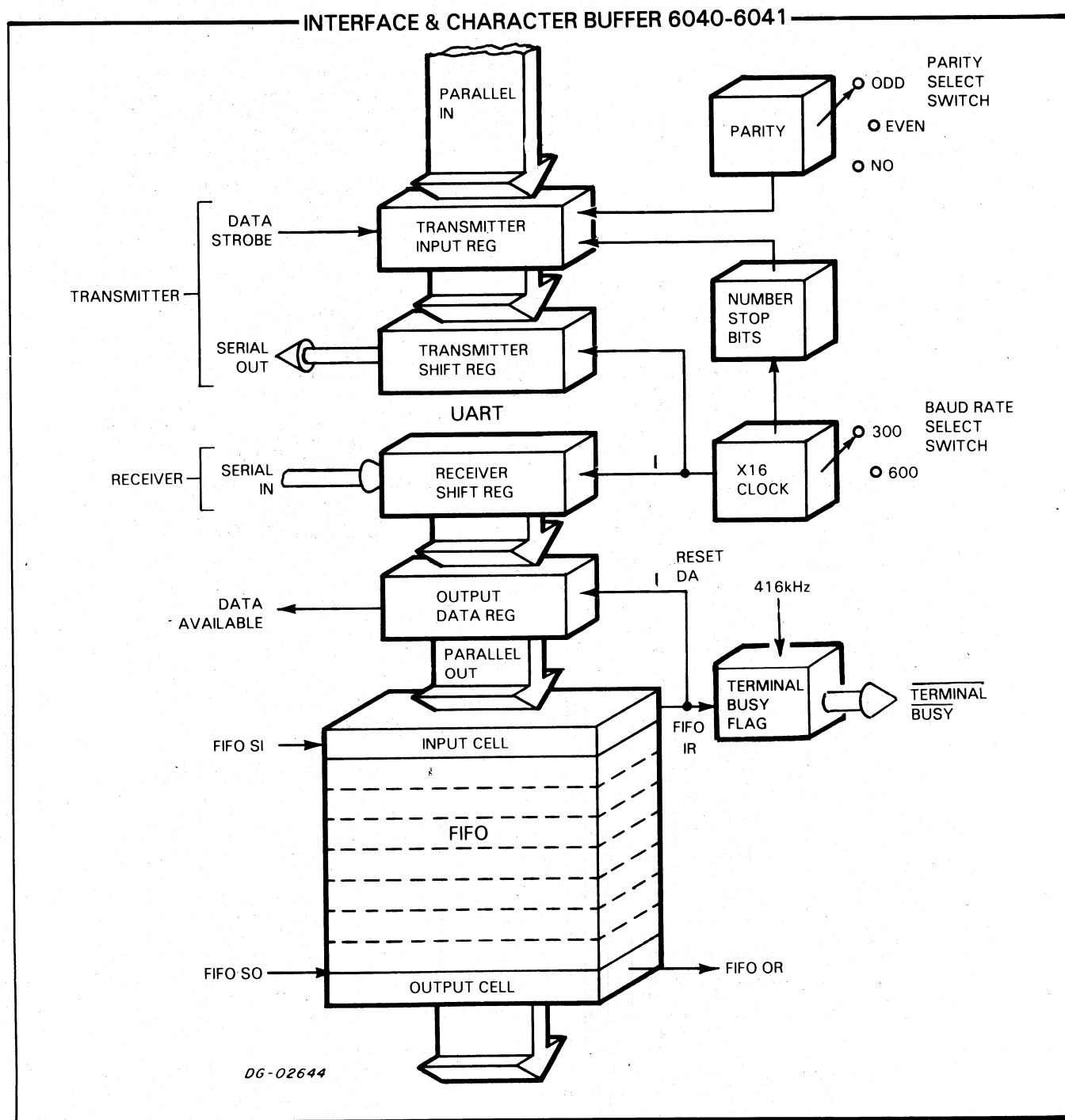

Terminal Busy Flag

The 6040 and 6041 terminals contain a Terminal Busy flag which informs the controller of the FIFO's status. Controllers intended for use with these terminals at 600 baud test the Terminal Busy flag before transmitting each character, and suspend the data transmission if the Terminal Busy flag is set to 1.

The Terminal Busy flag monitors the signal FIFO IR. As each character is loaded into the FIFO's input cell, FIFO IR is forced false. After the character moves from the input cell and falls into the FIFO stack, FIFO IR returns true. If the FIFO is full, the character remains in the input buffer and FIFO IR remains false. If it remains false for two consecutive periods of the 416MHz clock, the Terminal Busy flag is set to 1. The signal **TERMINAL BUSY** is sent to the controller via a 20mA current loop. The Terminal Busy flag is set to 0 when FIFO IR returns true.

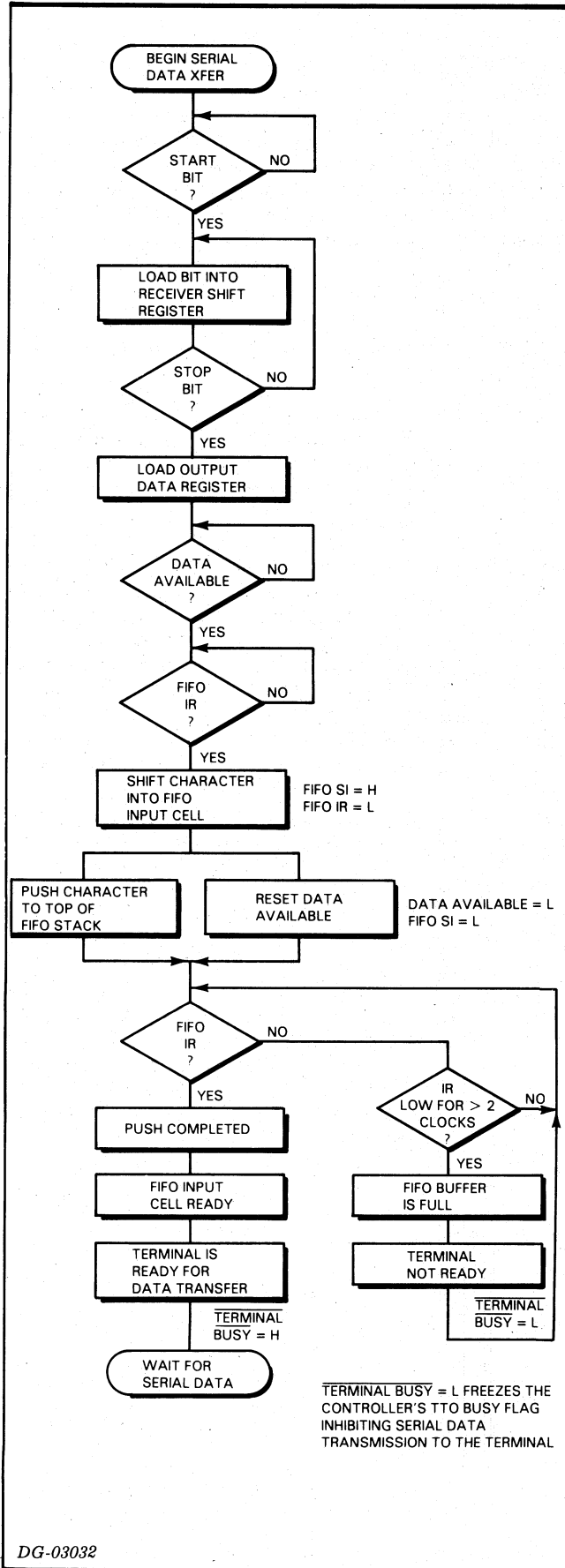

CHARACTER PRINTER

The character printer consists of a dot matrix printhead and related mechanism, a character generator, and solenoid drivers. It receives character codes from the FIFO buffer, selects those codes that represent printable characters and prints them on the paper. Certain groups of character codes are designated as printable or non-printable according to the configuration of selection jumpers on the printed circuit board.

Printhead/Carriage Assembly

The printhead/carriage assembly consists of a dot matrix printhead mounted on a carriage, and positioned in front of an adjustable platen. This assembly prints hard copy on paper forms. The dot

matrix printhead contains seven print-wires and an actuating solenoid for each wire. The wires are set in a straight line, angled at 10 degrees to the vertical; they print one slice of a 5-slice-wide character at one time. Some or all of the actuating solenoids may be energized simultaneously, depending on the character to be printed. A leaf spring on each wire holds the wire retracted; when the solenoid is activated, the wire is driven toward the paper and prints a dot through the ribbon. After the solenoid is de-energized, the spring returns the wire to the retracted position. The figure shows the dot matrix for the character R, and emphasizes the slices which comprise it.

The carriage travels on guide rails parallel to the platen, and slides on bushings. Electrical signals to the printhead solenoids are carried from the logic board by a ribbon cable clamped to a plug on the printhead.

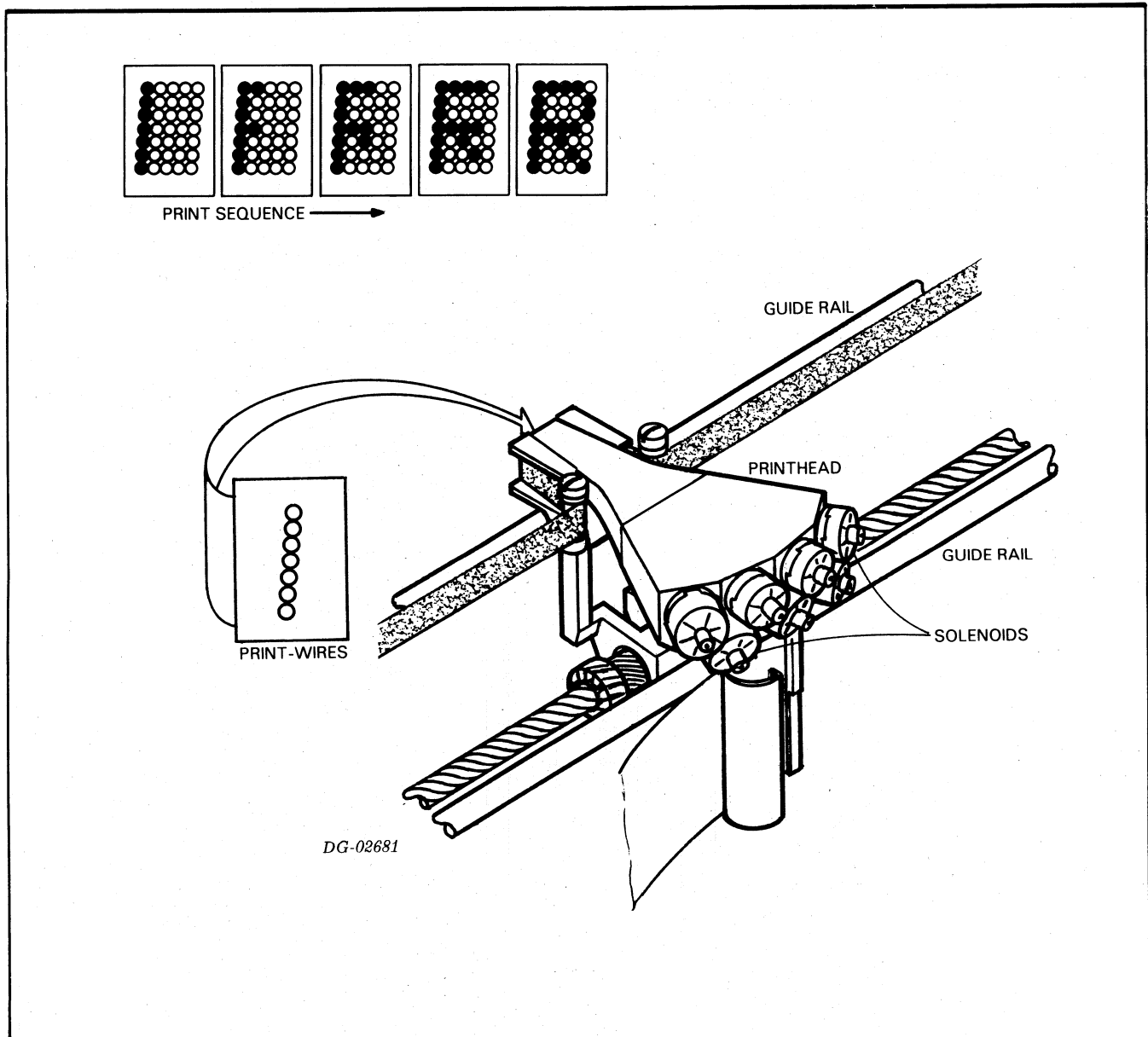

Print Controller

The print controller receives data from the character buffer, generates a 5X7 matrix for printable character codes, and fires the appropriate pin solenoids to construct the character image on the paper form. If the character decoded is a carriage return, the print controller activates the printhead positioner which moves the printhead to the home position so that the next character printed will be aligned with the left margin. A dual clocking scheme allows the printer to operate in a 'catch-up mode', printing characters at twice the normal speed at the beginning of each line.

The print controller incorporates a 128x7x9 column scan ROM character generator which contains a 5X7 matrix representation of each of the printable ASCII character codes and a decoder which defines which characters are printable, non-printable, and control characters. The inputs to the character generator ROM are a 7-bit ASCII character code as the character address and a 3 bit column address. The output from the ROM is one 7 row column of the the character matrix corresponding to the current address on the input column address lines.

The action of the character decoder is controlled by the position of decoder jumpers on the main printed circuit board. For all jumper positions, Carriage

Return, Line Feed, and BEL are control characters that is, no corresponding matrix is addressed in the ROM and no print sequence is initiated. The appropriate control function is executed by the terminal and the next character is decoded. Non-printable characters are the control characters and DEL for all jumper combinations, plus the octal codes 000 through 037₈ when the 95-character subset is enabled. No print sequence is initiated by non-printable characters; they are effectively ignored by the terminal and the next character in the buffer is decoded. The decoder also performs lower case to upper case alphabetic translations (foldover) when the 64-character subset is enabled.

Jumper positions to select various functions are tabulated in the installation data sheets cited in reference 1.

Solenoid Drivers

The solenoid drivers are transistor amplifiers which switch +30vdc to the printhead pin solenoids, energizing the solenoids, and causing the printhead pins to impact the paper form. The drivers are gated by a 420 microsecond timer synchronized to the printhead positioner by the print timing transducer.

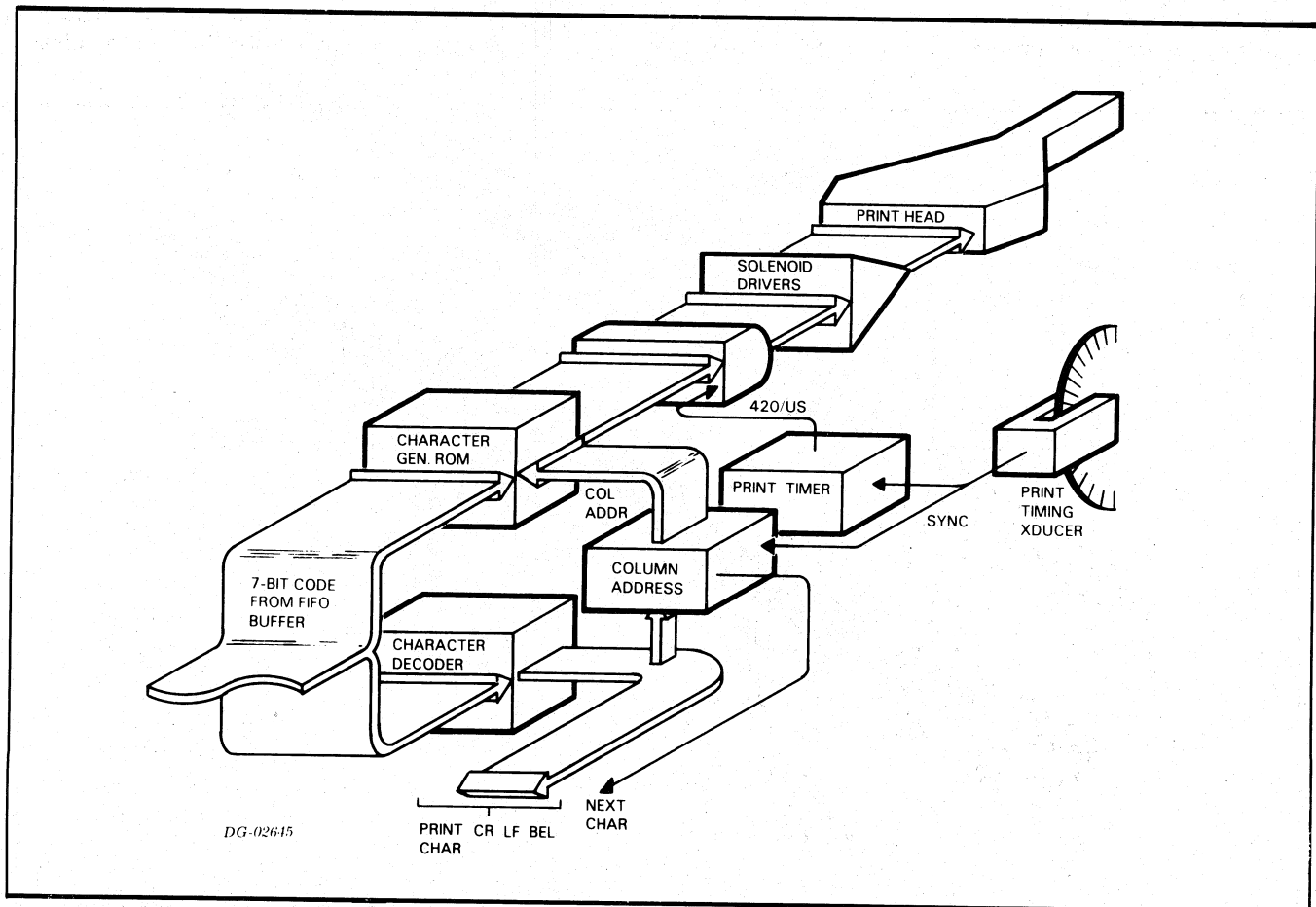

PRINthead POSITIONER

The printhead positioner moves the carriage forward. It also moves the carriage backward in response to Carriage Return codes. When the VIEW feature is enabled, the positioner moves the printhead away from the most recently printed characters so they can be seen. The positioner consists of a drive mechanism and a position controller.

Carriage Drive

The carriage drive system consists of a carriage drive motor, a lead screw and coupling, a timing disc and timing transducers, a 'carriage home' transducer, and carriage guide rails. The system moves the carriage across the platen, and provides electrical signals used to position the printhead during carriage returns and printing operations.

The lead screw is a threaded stainless steel rod which engages a threaded split nut in the carriage. Backlash is eliminated by a spring which compresses the nut on the screw threads. Two ball bearings support the lead screw, and it is coupled directly to the carriage drive motor with a flexible sleeve which is secured by clamp screws.

The carriage drive motor is a permanent magnet stepping motor, which is driven by a stepper control. The stepper control runs in open loop mode during

print operations and during short line (less than 8 characters) carriage returns. During longer carriage returns, the stepper control operates in closed loop (feedback) mode and uses timing signals from the timing transducers. These signals are used by the stepper system to control the carriage speed during these carriage returns.

A slotted disc is clamped to the motor shaft and rotates between two photoelectric transducers which are secured to a fixed bracket. As the disc rotates, the slots chop light beams which generate signals from the transducers. The signals from the print timing transducer are used to time the printhead solenoids when printing and, in conjunction with signals from the home flag transducer, to position the printhead at the left margin at the completion of a carriage return. The reversing transducer signals are used to control the carriage speed during long carriage returns.

The home flag transducer is a photoelectric element fixed to the printhead. A fixed bracket at the home (left margin) carriage position activates the transducer when the carriage passes it; the signals are used to decelerate the carriage drive motor and to reposition the printhead at the left margin.

The carriage guide rails are stainless steel rods, fixed in position, and parallel to the platen. The platen is mounted on adjusting cams, so that printhead to platen spacing may be adjusted by moving the platen.

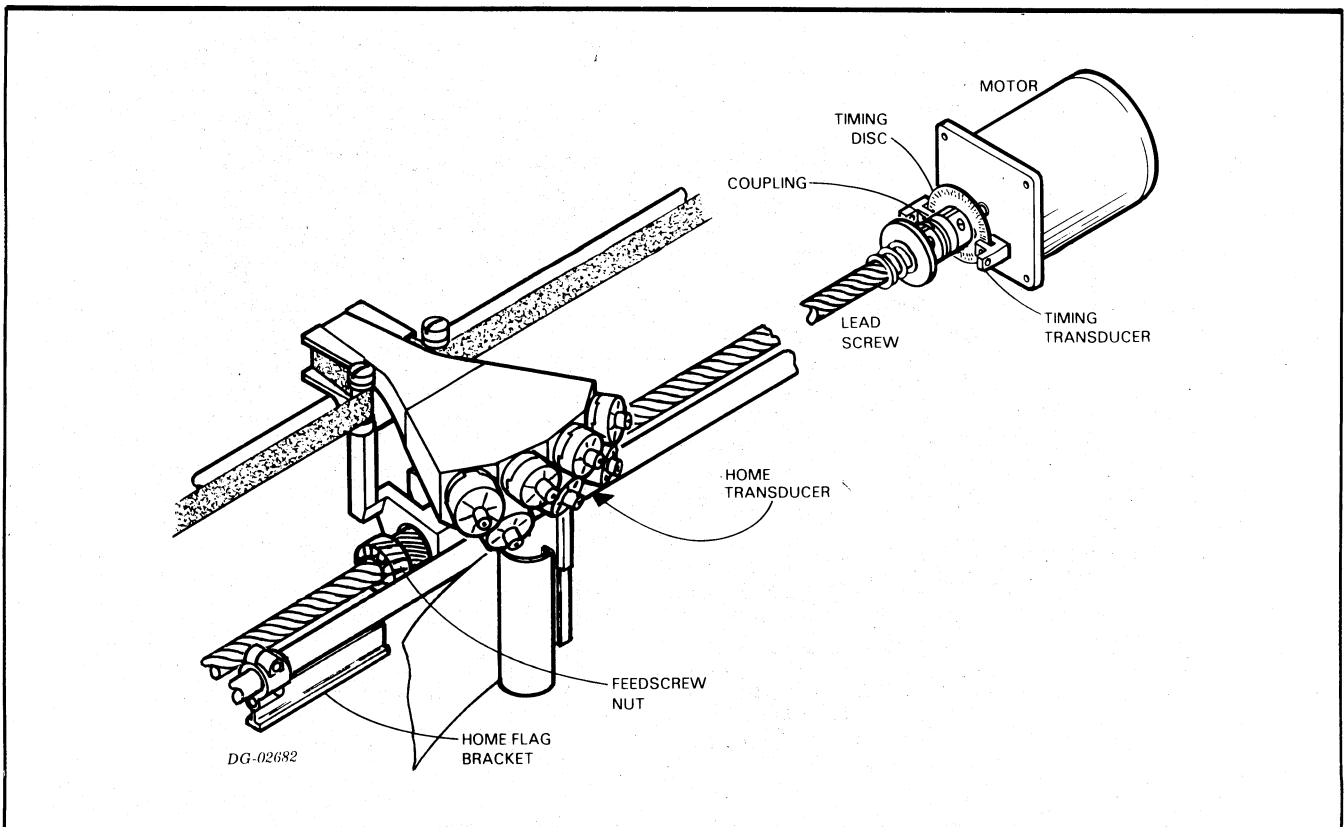

Position Controller

An understanding of the actions of the position controller depends on some familiarity with the operation of the stepping motor and the arrangement of the print timing and carriage return timing transducers. These are introduced separately below. The operation of the controller is then presented for three sequences: printing, carriage return, and VIEW.

Carriage Drive Motor

The carriage drive motor is a bi-directional stepping motor which advances six 5° steps in the forward direction for each character printed. During carriage returns it steps in the reverse direction until the print head passes the home position.

The permanent magnet rotor step motor is driven by four rectangular wave pulses whose phase relationship determines the direction of motion. The motor rotates one 5° step for each step pulse received. During printing, the carriage drive stepping motor rotates six steps each time a print sequence is initiated by the decoding of a printable character.

When the motor is driven by a periodic train of step pulses, it operates as a synchronous motor. The injection of an additional pulse to the pulse train driving step pulse generator accelerates the motor; the position of the additional pulse with respect to the other step pulses determines whether the acceleration is positive or negative. During carriage returns, the carriage drive stepping motor is driven by a step pulse train and decelerated by an additional pulse as the print head crosses the home position. Stepping motors require settling time outs whenever they are caused to stop or change direction so that oscillations of the motor shaft will dampen out. If a stepping motor receives a step pulse while the motor shaft is oscillating, the resulting direction of motion is unspecified.

The current through the step motor windings is controlled by the carriage motor drivers, transistor switches toggled by the step pulse generator. These transistor switches are depicted in the step motor diagram as the switches 1 through 6. Switches 1 through 4 control the phasing of the current in the motor windings, determining the direction of rotation. Switches 5 and 6 momentarily apply +30vdc to the motor to decrease the rise time of the current in the windings which are otherwise powered by the +12vdc supply.

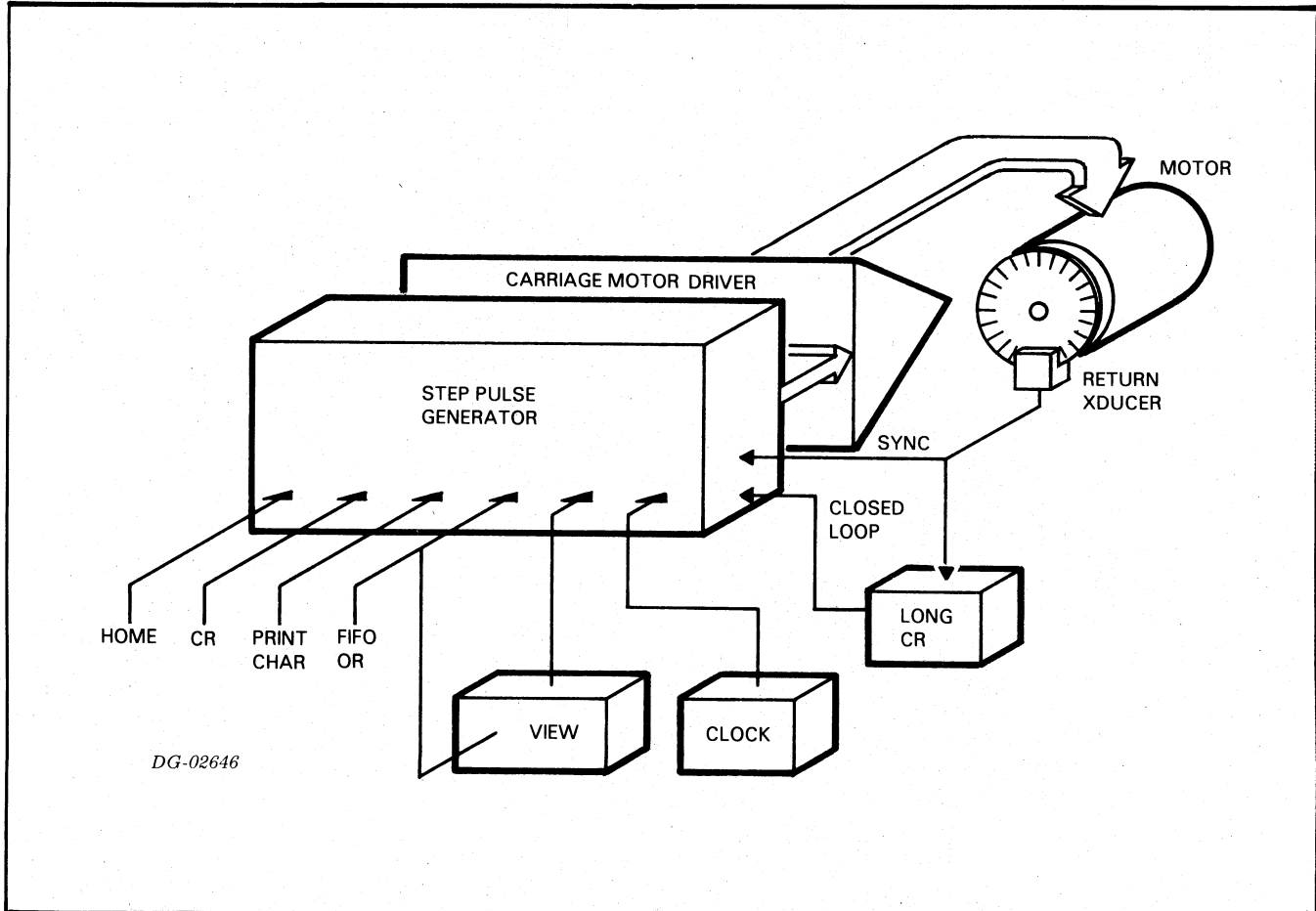

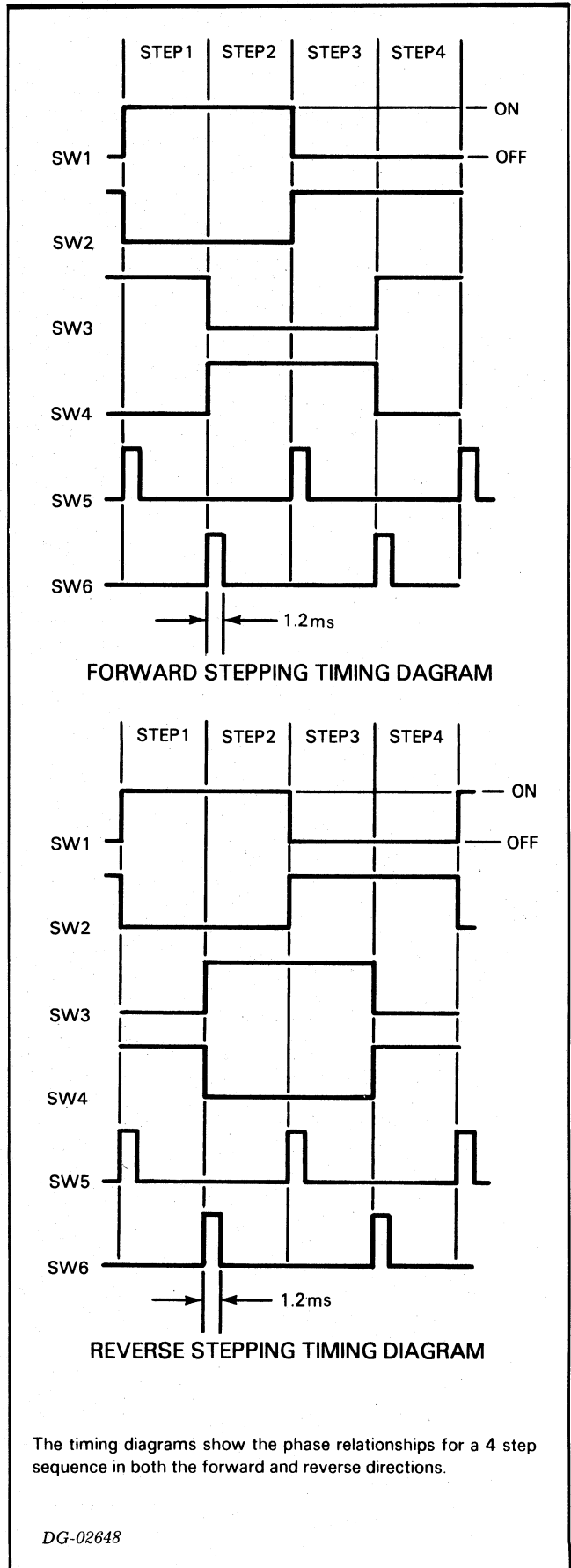
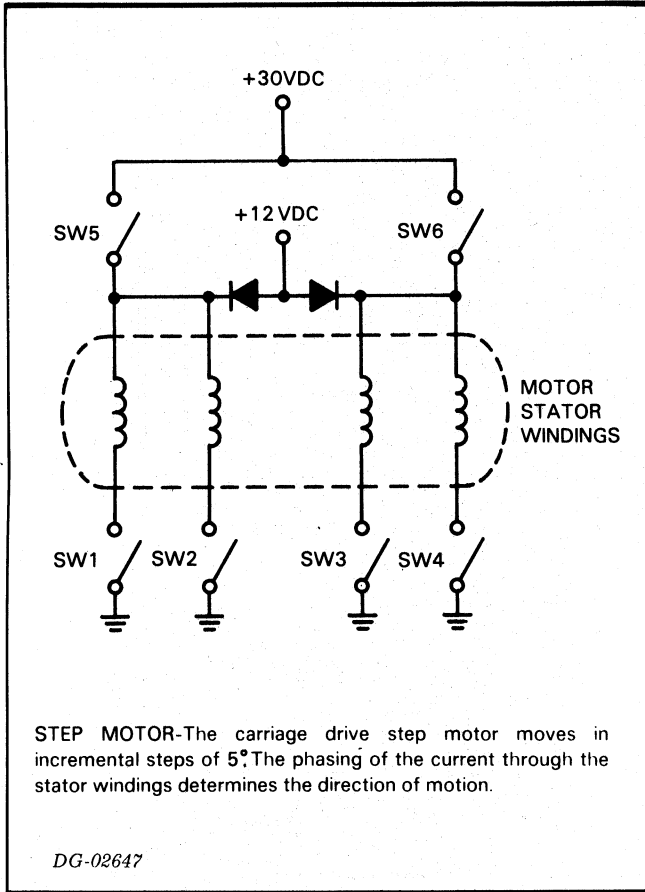

Timing Transducers

The timing transducer assembly consists of two optical switches and a slotted timing disk attached to the carriage drive step motor. The slots on the timing disk are aligned with the light paths of the optical switches and as the timing disk rotates with the carriage control step motor the light path is repeatedly broken.

The timing transducers perform two functions; one optical transducer, the print timing transducer, synchronizes the character column printing to the position of the printhead, and the other optical transducer, the return timing transducer, generates the step pulses which move the carriage drive motor during carriage returns.

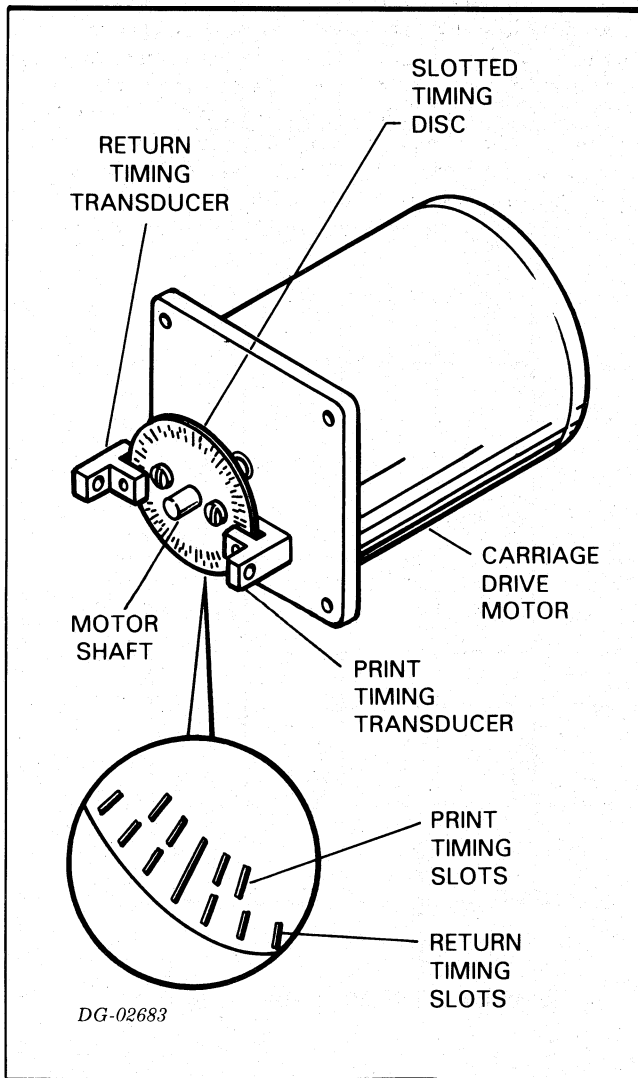

There are two sets of timing slots on the disk, the outer set is aligned with the return timing optical switch and the inner set is aligned with the column timing optical switch. Pulses from the return timing transducer generate the carriage drive motor step pulses to drive the motor in a closed loop mode for maximum speed during long carriage returns. The motor is accelerated from a standstill by logic generated step pulses; once in motion, the transducer generated pulses complete the carriage return. The column timing slots are arranged in groups of five. The five slots correspond to the five columns of the character matrix. The separation between the groups creates the inter-character spacing. Pulses from the column timing transducer gate the printhead pin solenoids allowing the selected pins to fire and increment the character generator ROM address to the next column.

Print Sequence

A print sequence begins when the print controller decodes a printable character. The carriage drive motor is set into motion by a 6 step pulse sequence. The first column of the character matrix is on the output lines of the character generator ROM which are connected to gates enabled by the print timing transducer. When the print timing pulse is detected the gates are enabled, the printhead solenoids energize, and the print pins impact the paper forming one column of the character matrix. The column address is incremented and the next column of the character matrix is placed on the output lines of the ROM. After the fifth column is printed a pulse is generated which resets the column address to zero. The next character is shifted out of the FIFO buffer and decoded and the sequence repeats.

When the terminal is receiving characters at baud rates of 110, 150, or 300, the print sequence goes to completion at twice its normal speed in order to maintain true data throughput of 10, 15 and 30 cps (respectively). By printing the characters at twice the rate they are received, the terminal can print any characters which may have accumulated during previous carriage return or View mode operations (both of which briefly suspend character printing). Characters received during a carriage return or View mode operation accumulate in the FIFO buffer. Double speed operation, or catch-up mode is initiated at the end of each carriage return and continues as long as more than one character remains in the buffer. The step motor pulse generator continually polls the status of the FIFO buffer to determine if it is empty or contains characters. If the buffer contains characters at the beginning of a new line, the carriage drive motor is stepped at the double rate and continues at this speed until the buffer is empty. When the position control has caught up with the FIFO buffer, the print sequence returns to its normal speed.

Carriage Return Sequence

The carriage return sequence is initiated when the print controller decodes a carriage return character. The step motor is set into motion in the reverse direction initially by logic generated step pulses. Printing is disabled and the next character is shifted to the output of the FIFO buffer. After the initial acceleration of the step motor the return timing transducer pulses are brought into a closed loop control configuration in which each pulse received generates the next motor step pulse. The step motor runs in this slew speed, closed loop mode until the home transducer detects the left margin.

When the print head reaches home it overshoots, decelerates, and returns to the home position. In order to decelerate the carriage drive step motor, one out-of-phase step pulse is injected into the step motor drive pulse train. As the motor decelerates the printhead engages the spring at the end of the feed screw and stops. The source of the motor drive pulses is switched from the closed loop return timing transducer pulses to the logic generated pulses. After a settling delay, the motor steps in the forward direction toward the home position.

Short line carriage returns are executed when the printhead is 8 columns or less to the right of the home position. During a short line carriage return the logic generated step pulses drive the carriage drive step motor in the reverse direction in the open loop mode only. Upon detection of home the motor stops and then, after a settling delay, steps in the forward direction toward the home position.

Before reaching the home position from the left, during either a long or a short line carriage return, the position control polls the status of the FIFO buffer. If the buffer is empty, the motor stops upon reaching home. If the buffer contains characters, the catch-up mode is initiated, the motor does not stop, and the first character is printed as the printhead crosses first character position.

An initial carriage return moves the printhead to the home position during the power-up sequence. The power supply begins the initial return by momentarily switching into a Reset mode when the power is turned on. The initial return is a short line carriage return, that is, the carriage drive motor steps under open loop control. The completion of the initial return illuminates the Ready light.

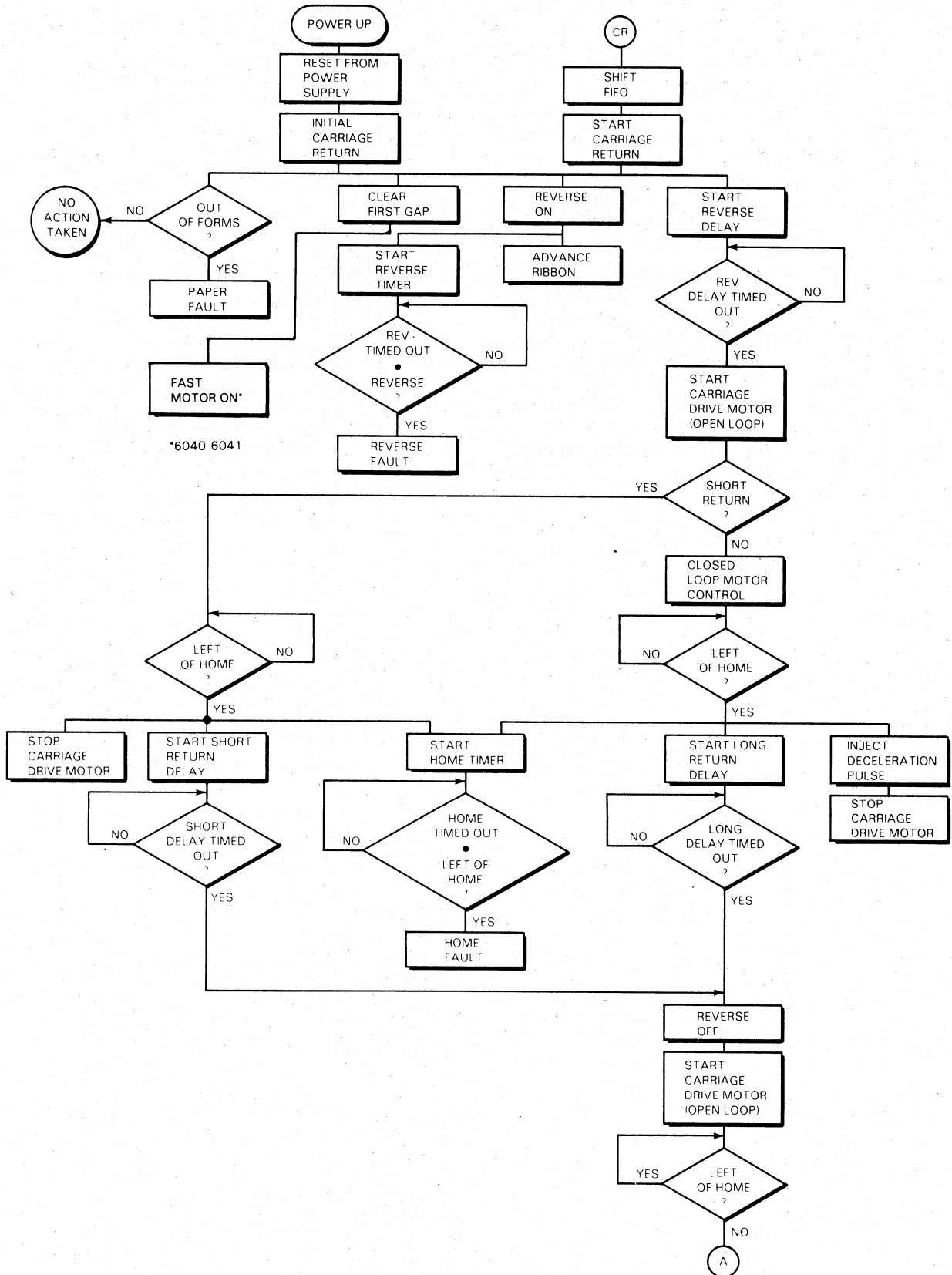

*6040 6041

Data General Corporation (DGC) has prepared this manual for use by DGC personnel and customers as a guide to the proper installation, operation, and maintenance of DGC equipment and software. The drawings and specifications contained herein are the property of DGC and shall neither be reproduced in whole or in part without DGC's prior written approval nor be implied to grant any license to make, use, or sell equipment manufactured in accordance herewith.

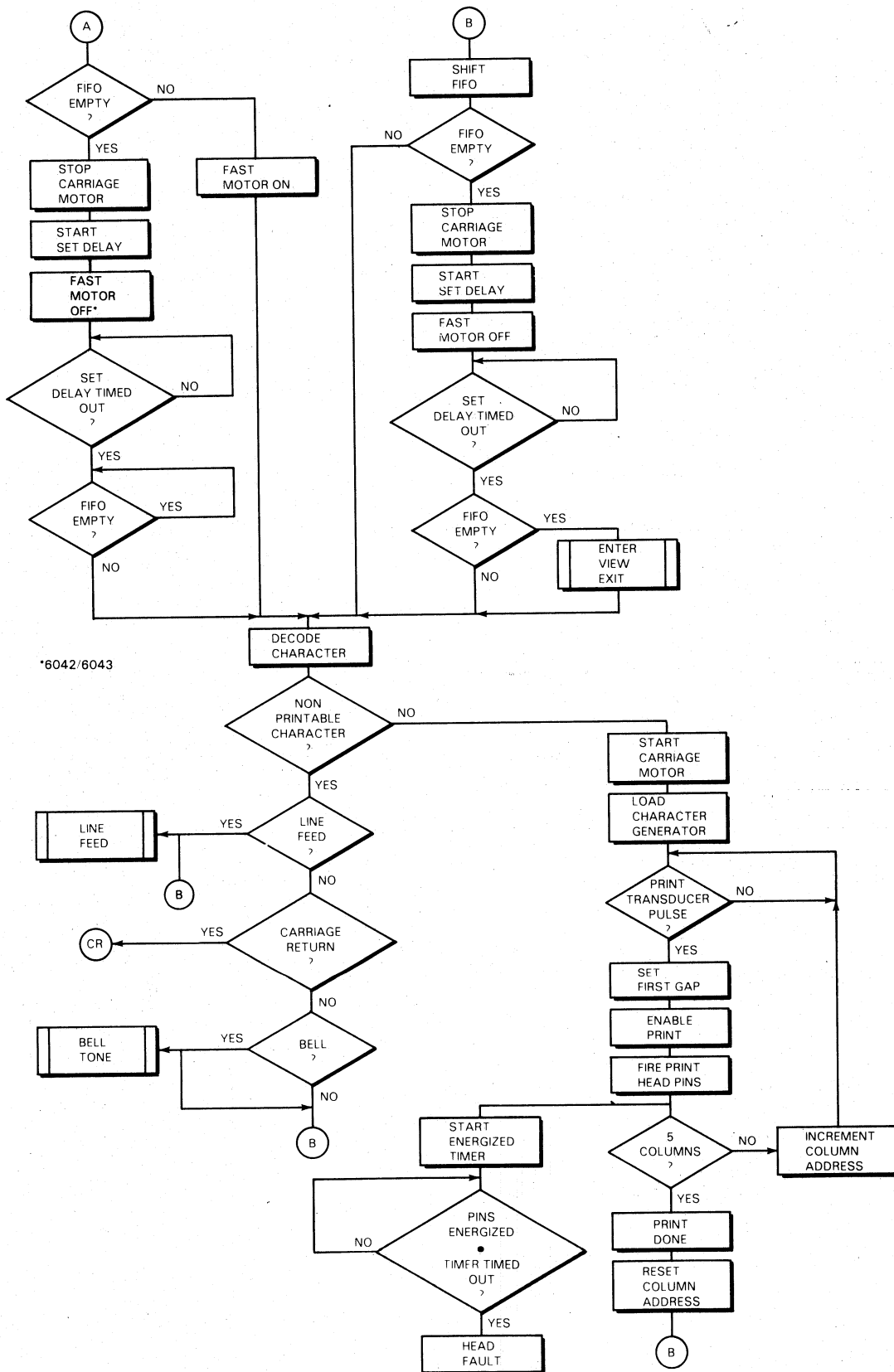

*6042/6043

V

View Sequence

During lapses in data reception of more than 1.2 seconds, the position controller begins a view sequence. The view mode disables the print sequence and moves the print head 6 columns to the right to permit viewing of the last character printed. If the printhead is to the right of the carriage right switch (approximately column position 126) when the view mode is initiated the printhead moves 6 columns to the left. Reception of a character terminates the view mode; the printhead returns to its previous position, stops, and the print sequence is allowed to begin.

The view sequence is disabled after each carriage return by the signal **FIRST GAP** which is not asserted until the first character is printed on that line. **FIRST GAP**, when not asserted means that the FIFO buffer was found to be empty after a carriage return and the print head has stopped to the left of the first character position (the first inter-character gap).

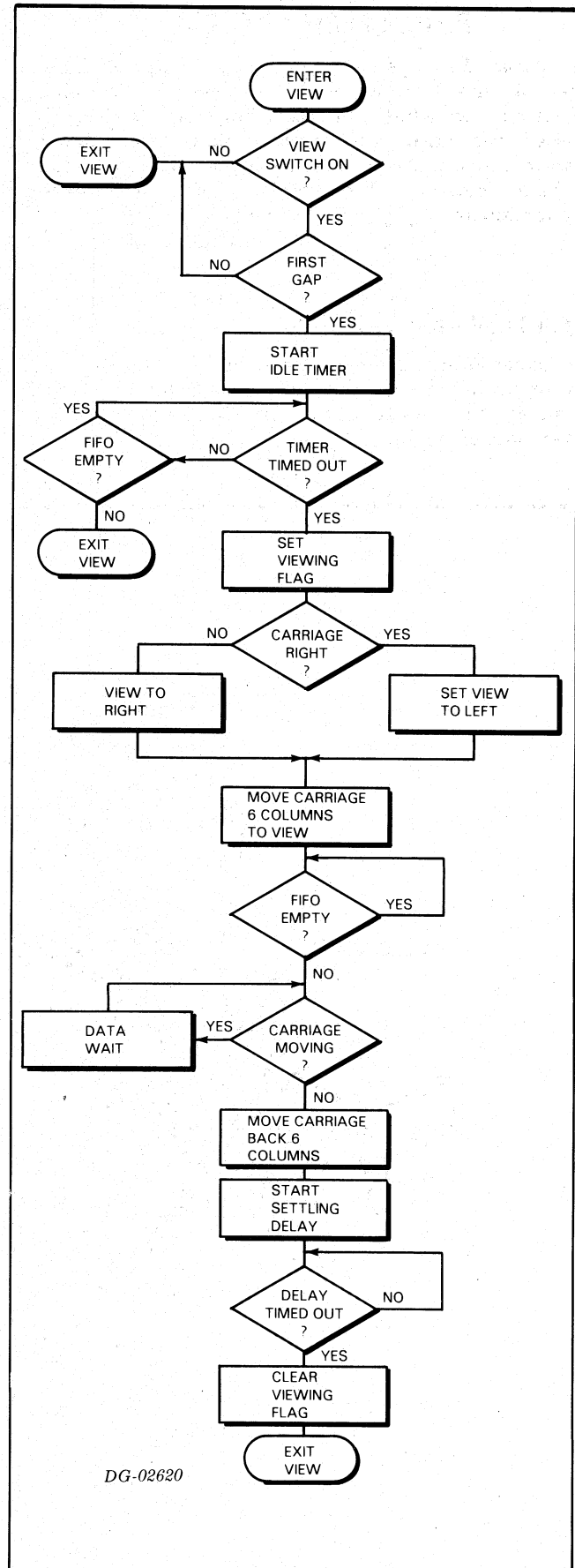

PAPER FEED SYSTEM

The paper feed system moves paper upward 1/6in when a line feed character is received (on line operation) or when the local line feed switch is pressed rearward. The system moves the paper upward continuously while the local line feed switch is held forward. The system contains a feed mechanism and a paper feed control.

Paper Feed Mechanism

The paper feed drive consists of pin-feed tractors, a tractor drive motor, and a drive belt. This assembly advances the paper form across the platen in increments of one line.

The tractor unit is composed of two tractor mechanisms mounted on a driveshaft and a guide rail. Each mechanism has a rubber belt with molded pins to engage the paper form. Four pins engage each edge of the form to provide driving force and prevent paper tearing. A spring-loaded door on each mechanism holds the form against the pins. Both tractor mechanisms are adjustable along the guide rail to accommodate various form widths and margins; each mechanism is secured in position with a knob which clamps to the guide rail. The driveshaft is square in cross-section to mechanically synchronize the tractor pins.

The tractor drive motor is a permanent magnet stepping motor which is connected to the driveshaft via a timing belt. Four motor pulses advance the paper one line.

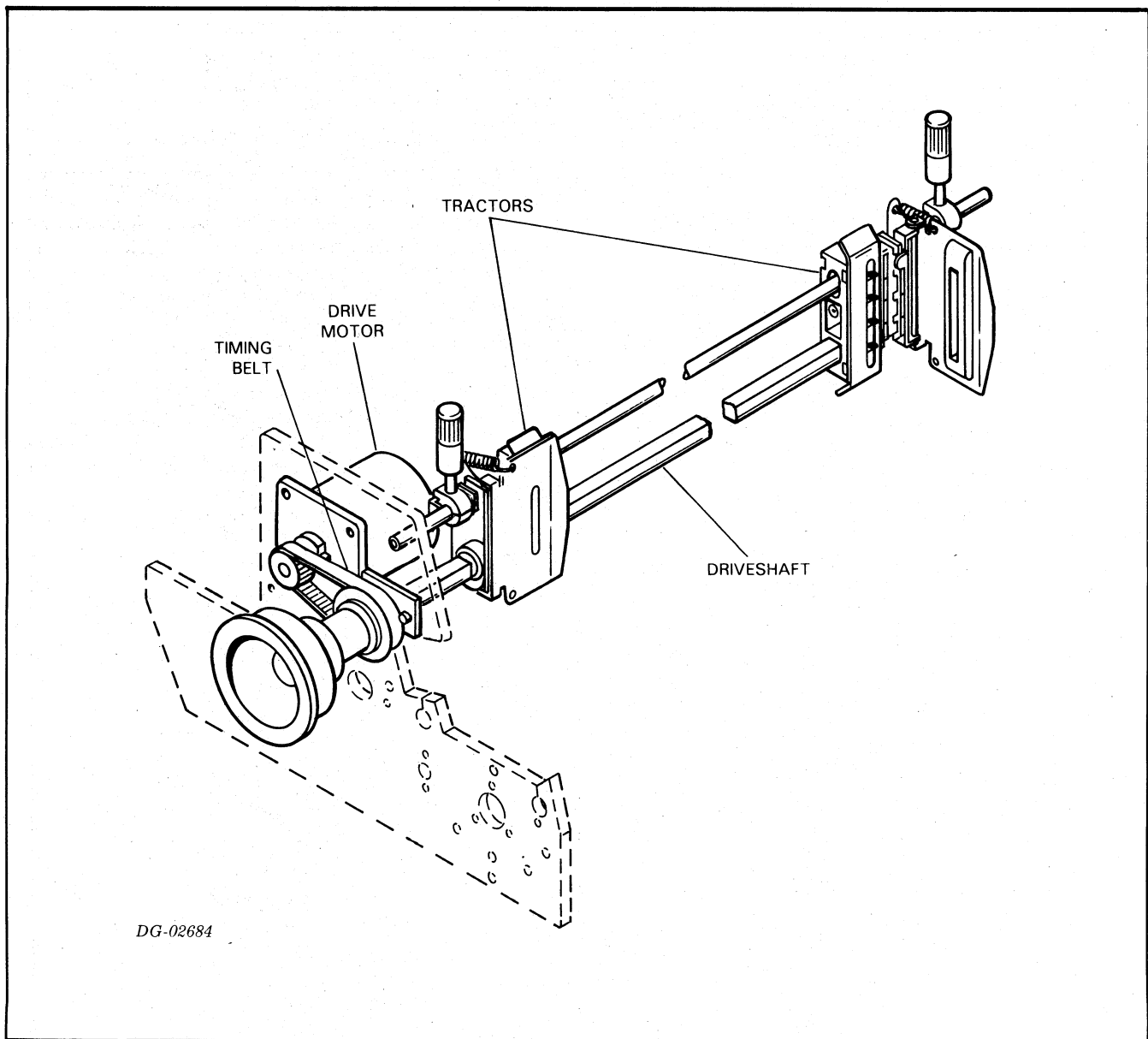

V

Paper Feed Controller

The paper feed control responds to octal code 012, the Line Feed command, and to the line feed switch located on the operators control panel. The control is an open loop system which generates four step pulses for each single step line advance.

When the character decoder detects a Line Feed command or when the Line Feed switch is pressed rearward, the paper feed control starts a timer which enables the step pulse generator. It generates four step pulses, amplifies them, and applies them to the paper feed stepping motor. The motor advances four 15° steps moving the paper form 1/6 of an inch upward. When the Line Feed switch is pressed forward, the control generates a continuous stream of pulses to drive the motor.

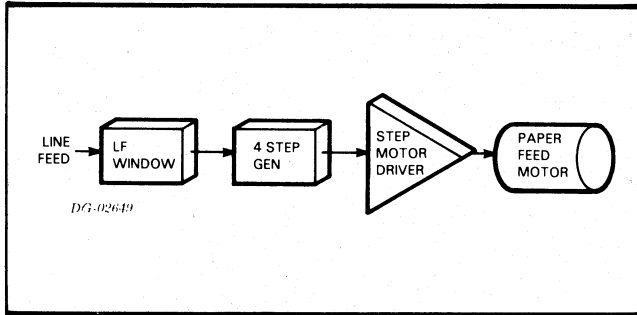

RIBBON FEED

The ribbon feed moves the ribbon during carriage return sequences and reverses the direction of ribbon feed when an end-of-ribbon rivet actuates a ribbon-reverse switch. The system consists of a drive mechanism and a controller.

Ribbon Drive

The ribbon drive consists of two spool seats, a swing-arm gear train, a drive motor, two ribbon reversing switches, and a ribbon wind switch. The spool seats are hub and shaft assemblies which hold the ribbon spools; each seat is preloaded with a friction washer to maintain correct ribbon tension. The ribbon motor drives one of the ribbon seats (and its spool) through the swing-arm gear train. The arm swings from one ribbon seat to the other as the motor rotation reverses.

The ribbon drive motor is an ac induction motor which is activated during carriage returns, and is coupled to the ribbon spools through the gear train described above.

Two ribbon reversing switches reverse the direction of ribbon motion when either switch senses the end of the ribbon (i.e. supply spool nearly empty). The ribbon passes through both switches, and a rivet near the end of the ribbon mechanically triggers the switch. The switches may be operated manually to reverse ribbon direction when rewinding the ribbon or when printing.

The ribbon advance switch is an operator control used to wind the ribbon. This switch is enabled when the terminal is on or off-line, and is used when changing the ribbon or when performing maintenance procedures.

Data General Corporation (DGC) has prepared this manual for use by DGC personnel and customers as a guide to the proper installation, operation, and maintenance of DGC equipment and software. The drawings and specifications contained herein are the property of DGC and shall neither be reproduced in whole or in part without DGC's prior written approval nor be implied to grant any license to make, use, or sell equipment manufactured in accordance herewith.

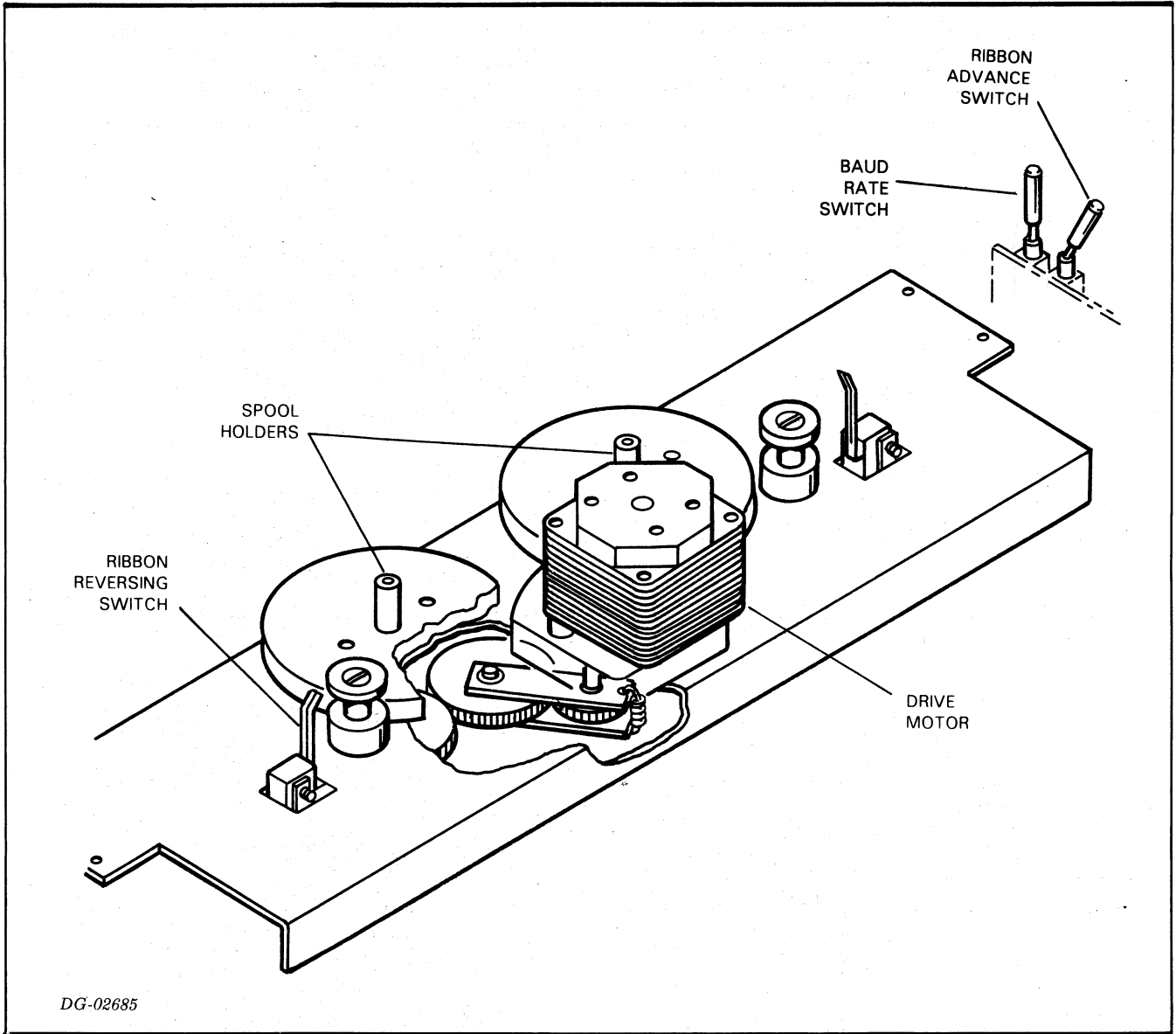

V

Ribbon Control

The ribbon control advances the ribbon during the carriage return time interval or for 200ms, whichever is longer. At the start of a carriage return the carriage control asserts the signal **REV** informing the ribbon control that the print head is moving in the reverse direction; the ribbon control then starts a 200ms timer. Either the output of the timer, the **REV** signal, or the ribbon advance switch, in the closed position, advances the SCR switch which supplies an ac return for the ribbon motor.

The direction of the motor is controlled by a magnetic latching relay and a phase shift capacitor located on the power supply printed circuit board. The relay is a

double-pole self holding relay; once the relay coil is energized by a voltage of either polarity, the contacts remain closed until the coil is energized by a voltage of the opposite polarity. The relay then switches, latching against the other contacts. The end-of-ribbon detectors, activated by the ribbon reverse switches, energize the relay coil. The relay contacts select which winding of the ribbon drive motor receives the leading voltage phase angle, determining the direction of motor motion.

Motion of the ribbon drive motor is defeated by either a Home fault or a Reverse fault to avoid continuous ribbon winding if a malfunction occurs during a carriage return.

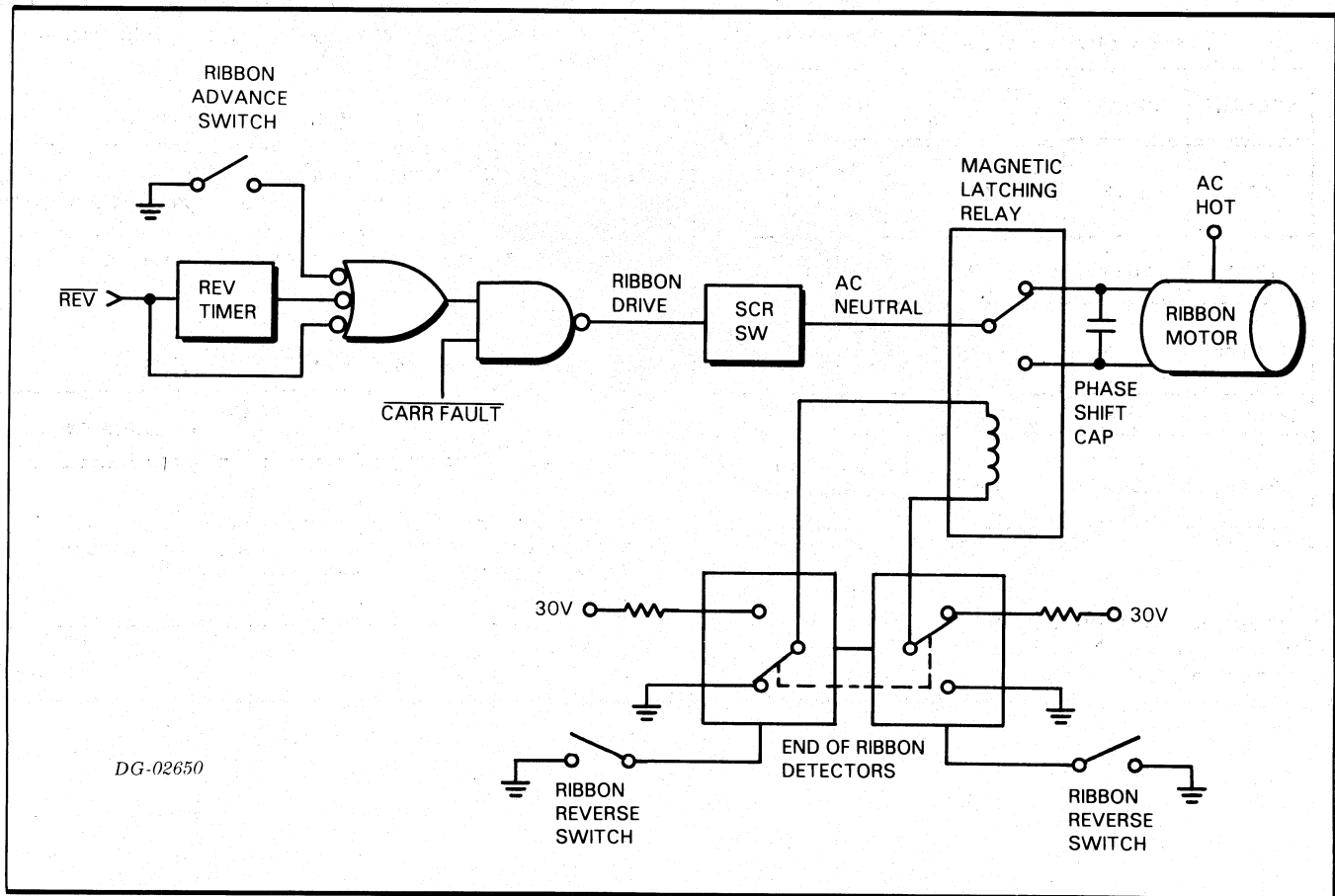

POWER SUPPLY

The terminal's power supply produces regulated outputs of -3vdc, -12vdc, +12vdc, +30vdc, and +5vdc given an input voltage of 100vac, 120vac, 220vac, or 240vac within a frequency range of 47 to 63 Hz. In addition to the DC voltage outputs, a **RESET** signal is also generated by the power supply to initialize the logic during the power-up sequence and to protect the circuitry against faults. Two techniques of regulation are employed in the data terminal's power supply; shunt regulation for the -3vdc and the -12vdc sections, and pulse width modulated (PWM) switching regulation for the +30vdc, +12vdc, and the +5vdc sections. The output voltages and their current ratings are summarized in the following table.

POWER SUPPLY OUTPUT VOLTAGES

VOLTAGE	CURRENT	TYPE OF REGULATION	WHERE USED
+12Vdc	3.5A	PWM	STEPPING MOTORS, CHARACTER GENERATOR
-12Vdc	50mA	SHUNT	UART, FIFO KEYBOARD
+30Vdc	3.5A	PWM	STEPPING MOTORS, PRINTHEAD
+5Vdc	3.A	PWM	LOGIC
-3Vdc	20mA	SHUNT	CHARACTER GENERATOR

DG-02867

The type of regulaton used in the -12vdc and the -3vdc sections is a zener diode shunt. The output of a fullwave bridge rectifier, connected to the line

transformer's secondary winding, is filtered by a capacitor and impressed across a zener diode. The zener diode maintains a constant voltage across its terminals, within certain current limitations, and thereby regulates the output voltage.

The type of regulation used in the +30vdc, +12vdc, and the +5vdc sections is pulse width modulated (PWM) switching regulation. Switching regulators are a highly efficient and accurate means of regulating output voltages from changes due to line and load variations. Regulation is accomplished by changing the duty cycle (the on-time divided by the period) of a fixed-period switched dc voltage to compensate for changes in either the input or output voltage. The output voltage to a constant load is proportional to the duty cycle, increasing the duty cycle increases the output voltage; decreasing the duty cycle decreases the output voltage.

In addition to the regulating circuits, the power supply contains circuits for over voltage protection, under voltage protection, and over current protection. These protection circuits safeguard the power supply components against short circuits to the output voltages and extreme changes in the input line voltage.

POWER SUPPLY AC INPUTS

LINE VOLTAGE (\pm v)	CURRENT DRAW	FREQUENCY
100V+10V-15V	2.5Arms	47 - 63Hz
120V+12V-18V	2.2Arms	
240V+22V-33V	1.2Arms	

DG-02817

Data General Corporation (DGC) has prepared this manual for use by DGC personnel and customers as a guide to the proper installation, operation, and maintenance of DGC equipment and software. The drawings and specifications contained herein are the property of DGC and shall neither be reproduced in whole or in part without DGC's prior written approval nor be implied to grant any license to make, use, or sell equipment manufactured in accordance herewith.

PWM REGULATED DC OUTPUT VOLTAGES

VOLTAGE	LINE REGULATION	LOAD REGULATION	RIPPLE	NOISE*	OVERSHOOT**	POWER FAIL RIDE THROUGH	OVER CURRENT	OVER VOLTAGE
+5V \pm 1%	\pm 2%	N/A	50mVp-p	\leq 20mV	100mV \leq 1.5mS RECOVERY TIME	\geq 40mS DROPOUT FROM NOMINAL LINE	POWER FOLDBACK FOR \geq 10A TOTAL CURRENT THROUGH MAIN SWITCH	LATCH INHIBIT FOR 30Vdc \geq 36V OR 5Vdc \geq 6.0V
+12V \pm 7%	\pm 5%	\pm 5%	100mVp-p	\leq 40mV	300mV \leq 2.5mS RECOVERY TIME			
+30V \pm 7%	\pm 5%	\pm 5%	100mVp-p	\leq 50mV	250mV \leq 2.5mS RECOVERY TIME			

*NOISE MEASURED AT MAIN PCB

**OVERSHOOT MEASURED USING 1 AMP STEP LOAD

DG-02816

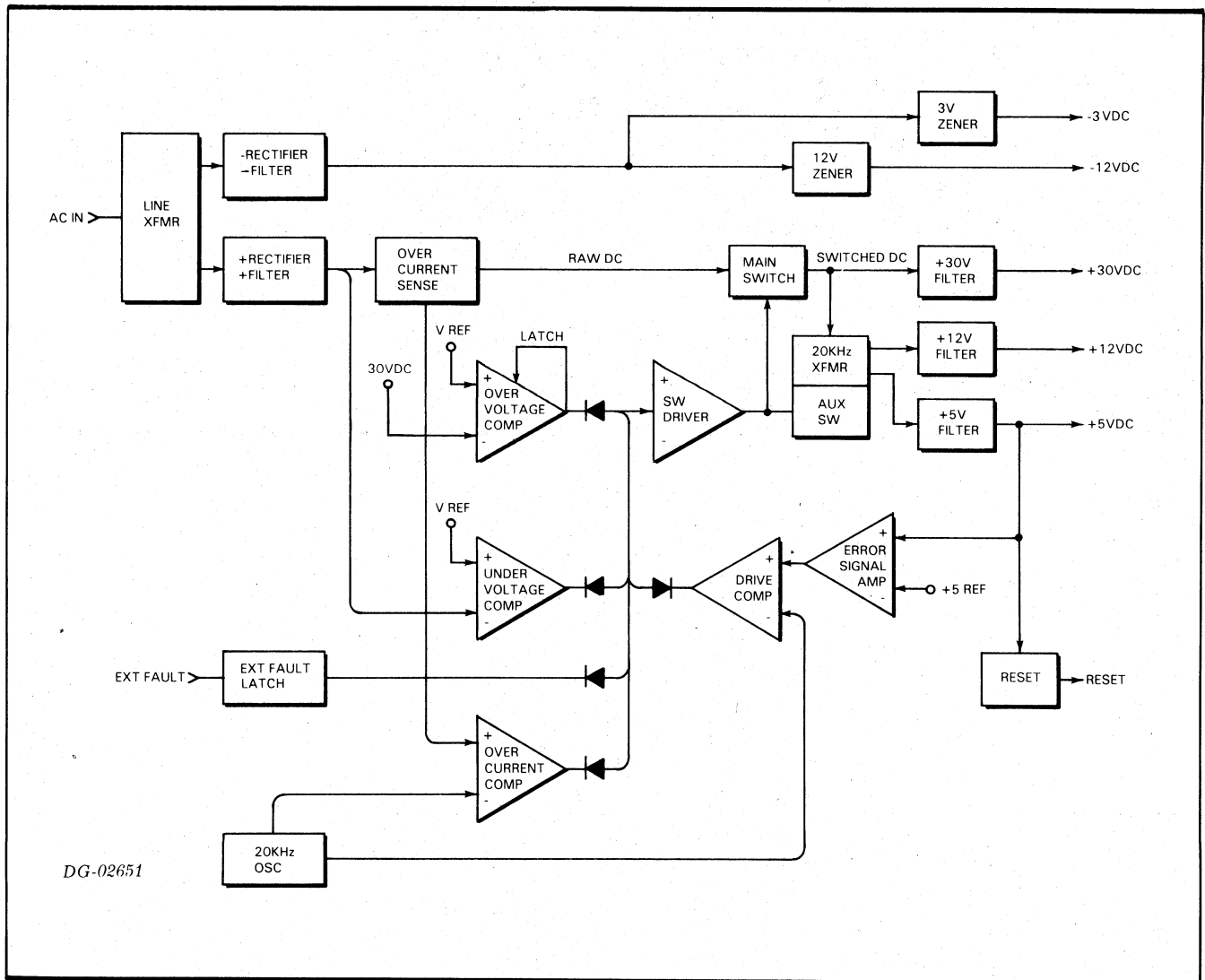

Pulse Width Modulated Switching Regulators

The PWM switching regulator of the power supply is depicted in the function block diagram below. The regulator is a closed loop feedback system whose error signal is the difference between the filtered +5vdc output and a 5 volt reference obtained from a 1% 5 volt zener diode. All three output voltages derive from the same source, the switched 30 volts, and are proportionally related to each other by the turns ratio of the 20kHz transformer. By using only the +5vdc output in the feedback loop, line regulation is obtained for all voltages since changes in the line voltage are linearly reflected to the output voltages in corresponding proportions. Correcting the +5vdc output from a change due to a line variation also corrects the +12vdc and the +30vdc outputs. The +5vdc output is both line and load regulated; changes in the +5vdc due to load variations are sensed in the feedback loop and compensated for.

Located near the center of the block diagram is the 20kHz oscillator. The oscillator supplies two outputs, a rectangular waveform which resets the over current comparator and a triangular waveform which switches the drive comparator and fixes the switching period at 50 microseconds.

The function blocks involved in the feedback control loop are the error signal amplifier, the drive comparator, the switch driver, the main switch, the auxiliary switch and 20kHz transformer, and the +5 volt filter. The error signal amplifier is an operational amplifier whose output is proportional to the difference between the 5 volt reference applied to the non-inverting input and the filtered +5vdc output applied to the inverting input. This error signal is the non-inverting input to the drive comparator, an op amp connected in a uni-polar supply, open loop gain configuration. The inverting input to the drive comparator is the triangular output from the 20kHz oscillator. Whenever the voltage of the triangle wave is less than that of the error signal, the op amp is driven into positive saturation and the output equals $V+$ which is +24vdc. As the triangle ramps up, it eventually becomes greater than the voltage level of the error signal; when this happens, the drive comparator op amp is driven into negative saturation and the output goes to $V-$ which is ground.

The drive comparator switches between saturation states creating a rectangular output with a 50 microsecond period. The pulse width or duty cycle is determined by the level of the error signal. This variable pulse width rectangular waveform is coupled through the switch driver and controls the main

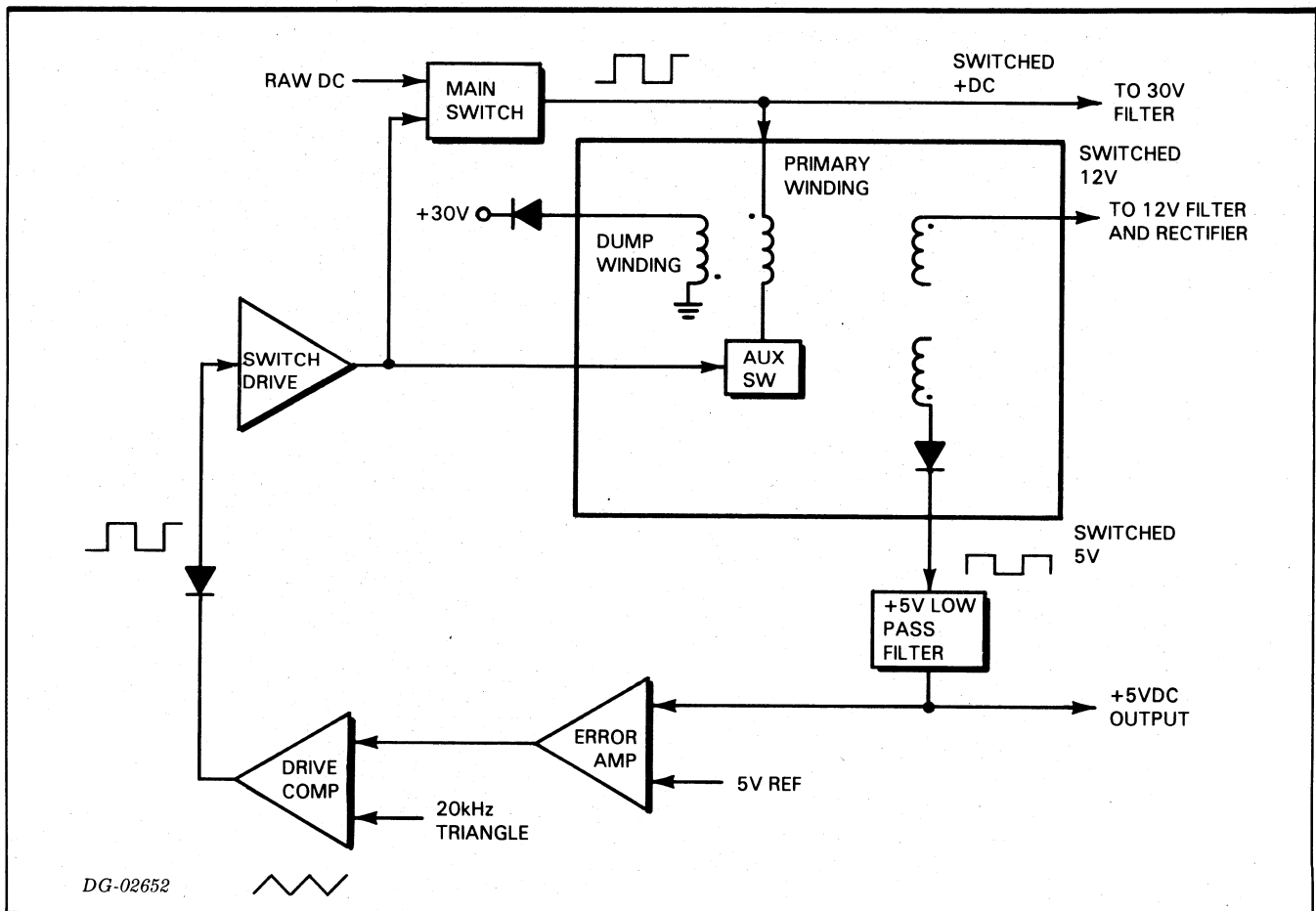

DG-02652

switch which chops the RAW DC. The output of the main switch, SWITCHED DC, has a duty cycle which varies between 50% and 67% keeping its average dc value at 30 volts.

The SWITCHED DC is coupled across a transformer whose turns ratio steps down the voltage. The switched 5 volts is rectified and passed through the +5v low-pass filter which averages the waveform into a +5vdc level. The +5vdc is applied to the inverting input of the error amp, completing the loop. The duty cycle of the SWITCHED DC varies in order to keep the +5vdc output equal to the reference voltage.

Another winding on the 20kHz transformer and two similar low-pass filters produce the +12vdc and +30vdc outputs. The SWITCHED DC from the main switch is averaged by a low-pass filter to produce the +30vdc output. The 12 volt winding of the 20kHz transformer steps down and couples the SWITCHED DC waveform to a rectifier. This rectified switched 12 volts is averaged by a low-pass filter to produce the +12vdc output.

The fourth winding of the 20kHz transformer is the dump winding. The dump winding and the auxiliary switch regulate the current flow in the transformer. No net DC current can be allowed to flow through the transformer primary winding or the transformer will quickly saturate creating extremely high currents when the switch is on. The auxiliary switch is driven by the switch driver and supplies a current path through the transformer primary to ground when the main switch applies the RAW DC to the transformer. When the switch driver opens the main and auxiliary switches, the energy stored in the magnetic inductance is shunted through the dump winding to the +30vdc supply, resetting the transformer core. The induced voltage in the dump winding inhibits the switch driver from operating until the transformer primary winding is completely discharged. This insures that the primary winding will not saturate by inhibiting the next switching cycle until the primary winding gives up the energy that it stored.

Over Current Protect

The over current protection circuit limits the total output current by lowering the output voltage. The over current sense determines if the RAW DC current to the main switch exceeds 10 amps. If an over current condition exists at the beginning of a switching cycle, the over current comparator inhibits the switch, terminating the on time of the SWITCHED DC waveform for the remainder of that period, limiting the output current. The 20kHz oscillator resets the over current comparator after each period causing the comparator

to check for an over current condition during each switching cycle. If the instantaneous current to switch exceeds 10 amps during several consecutive cycles the output voltages drop to near zero as the average duty cycle approaches zero.

Over Voltage Protect

The over voltage comparator compares the +30vdc output with a reference voltage and latches up, inhibiting the switch, when the +30vdc exceeds 36 volts. Unlike the over current comparator which resumes normal operation when the current returns to its rated value, the over voltage fault is non-recoverable. Once an over voltage fault is encountered the power supply is inoperable until the voltage has returned to its normal value and the terminal is shut down and powered up again.

Under Voltage Protect

The under voltage protection circuit inhibits the switching operation when the RAW DC voltage is less than 26 volts. Under normal operating conditions the under voltage protect disables the power supply during its power up sequence. This fault interlock clears itself when the voltage increases to 26 volts.

Reset (+5vdc Under Voltage)

Because the action of TTL logic is indeterminate when the 5 volt, Vcc supply drops below the tolerance of a logic 1, the +5 volt sense monitors the +5vdc output and generates a RESET signal when the +5vdc output falls below 4 volts. The RESET signal stops the operation of the terminal, but does not affect the power supply. Reset is part of the normal power up sequence; it initializes portions of the terminal's control logic and starts the initial carriage return sequence.

External Fault

The external fault latch is triggered by the HEAD FAULT signal from the Fault Detector. A Head fault indicates that current has been flowing through the print head solenoids for greater than 1ms. The external fault latch inhibits the switch driver, causing the PWM regulated voltages to drop to zero volts. The Head fault is non-recoverable; once a Head fault is encountered the power supply is inoperable until the Head fault interlock is cleared and the terminal is shut down and powered up again.

FAULT DETECTORS

The terminal is protected by a system of fault interlocks which halt the operation of the terminal in the event of a component malfunction or an unsafe condition. Several of these faults incorporate fault indicator lights to facilitate troubleshooting. There are six fault conditions; a summary of these faults follows.

Function	Fault Caused by
Over Voltage Fault	Power supply positive regulated output voltages have risen above maximum tolerance.
Head Fault	Print head pin solenoid energized for greater than safe time limit.
Home Fault	Print head remains to the left of home position.
Reverse Fault	Print head continually driven in reverse direction.
Paper Fault	Terminal is running out of paper forms.
Reset	Power supply +5vdc output is less than 4 volts.

Some of the faults affect the power supply while others affect the terminal's control logic. The Over Voltage fault and the Head fault inhibit the PWM switching regulator causing the terminal to completely power down. Both the Home and Reverse faults inhibit the carriage control motor step pulses, halting any print head motion. The Reset condition disables the sequencing logic and idles the terminal without affecting the power supply, and the Paper fault forces the terminal off-line.

The data terminal is equipped with five fault indicator lights in order to determine which of the faults halted the terminal's operation. Two of the indicator lights are located on the operator's control panel: the Ready light and the Paper Fault light. The three remaining indicator lights are located on the main printed circuit board as shown in the diagram: the Power OK light, the Reverse Fault light, and the Home Fault light.

The Ready light goes off whenever any fault exists, warning the operator that the terminal is no longer operable. The Power OK light, when on, indicates that the power supply is operating normally. When off, the Power OK light indicates that the power supply is in a Reset condition or that the power supply is disabled. The other lights are related to the faults in the following manner: the Home Fault glowing indicates a Home fault, the Reverse Fault glowing indicates a Reverse fault, and the Paper Fault light glowing indicates a Paper fault.

Over Voltage Fault

An over voltage fault occurs when the +30vdc regulated output from the power supply increases above 36 volts. The over voltage protect circuit compares the +30vdc with a reference and latches up, inhibiting the PWM switching regulator. All the positive voltages drop to zero causing a complete shut down of the terminal and all indicator lights are off.

Head Fault

A head fault occurs when current flows in any print head solenoid for more than 1ms in order to protect the solenoids from overheating and becoming damaged. Whenever current flows through a print head solenoid, a timer is started; if the solenoid is energized after the timer times out, a fault signal is sent to the power supply which activates a latch and inhibits the PWM switching regulator. All positive voltages drop to zero causing a complete shut down of the terminal and all indicator lights are off.

Home Fault

A home fault occurs when the print head remains to the left of the home position for more than approximately one second, or when a home transducer or a circuit failure erroneously indicates that the print head is to the left of home. The home transducer generates a **HOME** signal when the print head moves behind the home position and starts a timer; if **HOME** is asserted when the timer times out, the carriage control motor step generator is disabled halting the carriage control motor, and illuminating the Home Fault light.

Reverse Fault

A reverse fault occurs when the carriage control step motor is driven in the reverse direction for more than one second. Whenever the carriage control motor is stepped in the reverse direction the signal **REV** is asserted and a timer is started; if **REV** is present when the timer times out, the carriage control motor step generator is disabled halting the carriage control motor, and illuminating the Reverse Fault light. The terminal remains in the home fault condition until the **POWER** switch has been toggled.

Paper Fault

A paper fault occurs when the terminal runs out of paper forms. A switch located in the paper path

Data General Corporation (DGC) has prepared this manual for use by DGC personnel and customers as a guide to the proper installation, operation, and maintenance of DGC equipment and software. The drawings and specifications contained herein are the property of DGC and shall neither be reproduced in whole or in part without DGC's prior written approval nor be implied to grant any license to make, use, or sell equipment manufactured in accordance herewith.

senses the absence of paper in the paper path. If after a carriage return there are no paper forms in the paper path, the terminal is switched off-line and the Paper Fault light is illuminated.

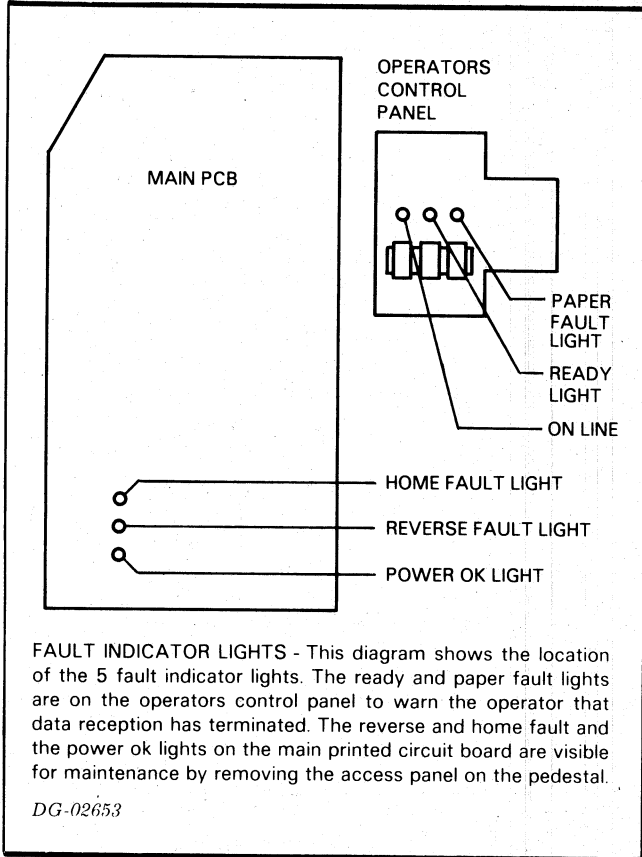

Reset

A reset fault occurs when the +5vdc regulated output from the power supply drops to less than 4 volts. Reset disables the carriage control and return sequencing logic and the print head solenoid drivers, stopping all terminal control functions. During Reset the Power OK light is off.

FAULT LIGHT SUMMARY TABLE

CONDITION	LIGHT				
	READY	PAPER FAULT	POWER OK	REV FAULT	HOME FAULT
NORMAL OPERATION	ON	OFF	ON	OFF	OFF
OUT-OF-FORMS	OFF	ON	ON	OFF	OFF
RESET	OFF	OFF	OFF	OFF	OFF
REVERSE FAULT	OFF	OFF	ON	ON	OFF
HOME FAULT	OFF	OFF	ON	OFF	ON
HEAD FAULT	OFF	OFF	OFF	OFF	OFF
OVER VOLTAGE FAULT	OFF	OFF	OFF	OFF	OFF

DG-02618

SECTION VI OPERATOR MAINTENANCE

INTRODUCTION

This section describes operator maintenance procedures recommended for Data General's 6042/6043 data terminals. Maintenance consists of periodically cleaning the mechanical assemblies; no lubrication of the assemblies is necessary.

Perform maintenance procedures according to the following schedule:

EVERY WEEK

Clean the printhead guide rails, the platen, and the tractor mechanism as follows:

- Turn the POWER switch to OFF. Unplug the power cord from the line supply outlet.
 - Lift up the top cover until it latches open.
 - Remove the paper from the terminal. Leave the platen in the rearmost position.
 - Remove the ribbon from the platen area. Slacken the ribbon sufficiently and lift it off the printhead and guides to expose the platen.
 - Use a lint-free tissue to wipe the carriage rails and lead screw. The tissue may be dampened with isopropyl alcohol if necessary.
 - Wipe the platen with a tissue. If the tissue is dampened with alcohol, ensure that the ribbon remains dry.
 - Wipe the tractor support shaft and drive shaft with a tissue. Clean any paper dust from the tractor assemblies.
 - Vacuum clean all debris and paper dust from the carriage cavity, using a non-conducting nozzle.
- Thread the paper through its guides and onto the printhead; take up any slack by rotating the idler spool. Be sure the ribbon follows the path outlined on a label atop the mechanism.
 - Replace the ribbon as described in the Operator's Section of this manual. Be sure to adjust the platen lever to give the desired print darkness for the form thickness used.
 - Release the top cover latch and close the cover.
 - Clean the outside of the terminal with a cloth dampened with a mild cleaning solution. Take care that no liquid enters into the keyboard or operator control panel.
 - Plug the power cord into the line supply receptacle and turn the POWER switch to ON.

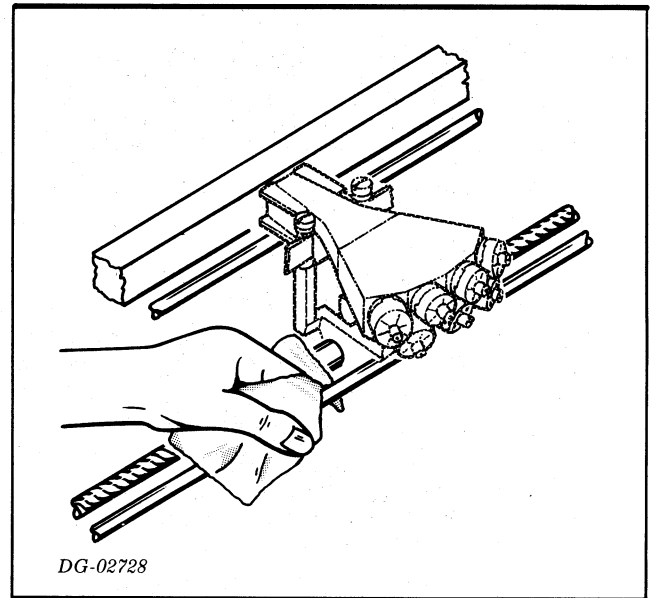

EVERY MONTH

Clean the two feed screw transducers and the slotted disc as follows:

- Turn the POWER switch to OFF. Unplug the power cord from the line supply outlet.
- Lift up the top cover until it latches open.
- Use a lint-free tissue or soft brush to wipe the transducer's faces as shown.

CAUTION *The slotted disc may be easily bent. Do not apply pressure to the disc with the tissue.*

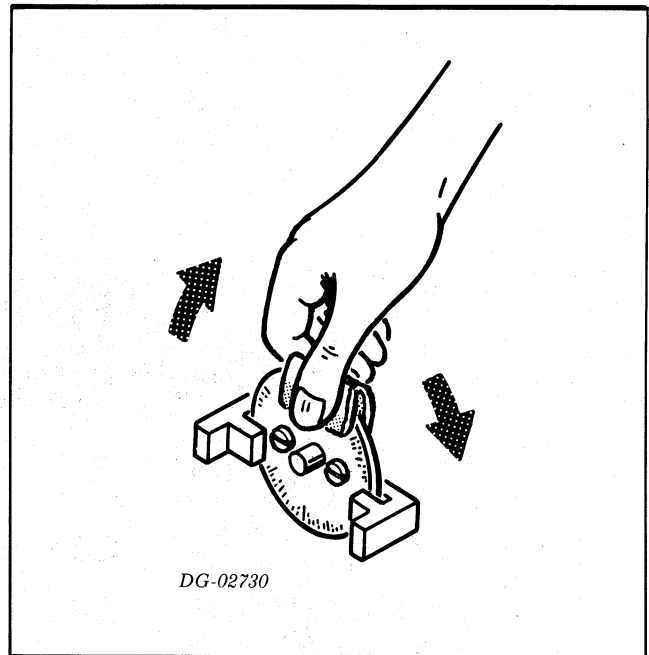
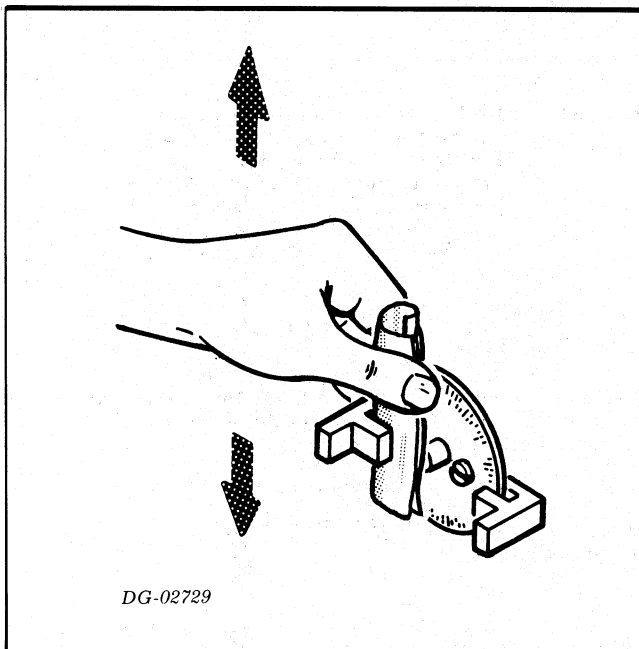

- Fold a lint-free tissue over the slotted disc and manually rotate the feed screw. The slotted disc will rotate and wipe clean on the tissue. Be careful not to bend the disc.
- Check that the transducers and disc are free of paper dust and other dirt. Repeat the cleaning procedure if they are not clean.
- Release the top cover latch and close the cover.
- Plug the power cord into the line supply receptacle and turn the POWER switch to ON.

APPENDIX A

TECHNICAL SPECIFICATIONS

MODEL 6042/6043

General

Maximum Throughput	30 characters/sec
Print Type	5 x 7 dot matrix 1.07in x 0.082in (nom.)
Character Sets	France Germany Japan Sweden United Kingdom United States
Character Subsets	96-character (standard) 126-character (field selectable) 64-character (field selectable)
Printhead Drive	Lead screw, permanent magnet stepping motor with open loop mode (while printing) and closed loop feedback control (carriage returns) Maximum carriage return time: 500ms Maximum slew speed: 2200 steps/sec (nom)
Print Technique	Impact through ribbon 7-wire, solenoid-actuated printhead
Solenoid Drive	Pulse Width: 420 μ sec (nom.) Actuating Voltage: 30Vdc Solenoid Current: 2.3A dc (max.)
Ribbon	0.5in wide, commercial spool mounted multi-pass, ink impregnated fabric: 40yds mylar: 80yds
Ribbon Drive	Spool to spool during carriage return ac induction motor with swing-arm gear train Auto-reverse at ribbon end Ribbon speed: 8.28 - 4.74 ips Drive motor output speed: 100rpm Spool rotation speed: 50rpm
Paper Forms	Pin-feed, fan-fold, 1 to 6 part paper maximum forms pack 0.025in Hole spacing: 0.5in centers (nom.) Forms weight: 15lb (first part) 9lb (2'nd - 6'th part) Form crimps: Tab type only

Paper Feed

Pin-feed tractors driven by permanent magnet stepping motor and timing belt
Feed drive rate 4-15deg steps
Tractor adjustment range: 4in to 15in
Vertical line spacing: 0.167in (nom.)
Time for single line feed: 33ms (nom.)
Continuous feed rate: 4.8ips (nom.)

Electrical

Interface	Plug compatible with DGC 20mA current loop and DGC standard EIA voltage interfaces 110, 150, 300 Baud only
Input Power	100, 120 220 240Vac (nominal) 47-63Hz
Power Dissipation	200 Watts (682 BTU/hr)
Power Cable	6ft

Mechanical

Dimensions	33.75in(h) 21in(d) 26.5in(w)
Weight	60lbs (27Kg)

Environmental

Temperature Ranges	Operating: 50degF--104degF (10degC--40degC) Storage/Shipping: -40degF--140degF (-40degC--60degC)
Humidity Ranges	Operating: 10%--90% (non condensing) Storage/Shipping: 5%--95% (non condensing)
Maximum Altitude	50,000ft

APPENDIX A (Continued)

MODEL 6040/6041

General

Data Rate (Transfer)	60 characters/sec
Print Type	5 x 7 dot matrix 1.07in x 0.082in (nom.)
Character Sets	France Germany Japan Sweden United Kingdom United States
Character Subsets	96-character (standard) 126-character (field selectable) 64-character (field selectable)
Printhead Drive	Lead screw, permanent magnet stepping motor with open loop mode (while printing) and closed loop feedback control (carriage returns) Maximum carriage return time: 500ms Maximum slew speed: 2200 steps/sec (nom)
Print Technique	Impact through ribbon 7-wire, solenoid-actuated printhead
Solenoid Drive	Pulse Width: 420 μ sec (nom.) Actuating Voltage: 30Vdc Solenoid Current: 2.3Adc (max.)
Ribbon	0.5in wide, commercial spool mounted multi-pass, ink impregnated fabric: 40yds mylar: 80yds
Ribbon Drive	Spool to spool during carriage return ac induction motor with swing-arm gear train Auto-reverse at ribbon end Ribbon speed: 8.28 - 4.74 ips Drive motor output speed: 100rpm Spool rotation speed: 50rpm
Paper Forms	Pin-feed, fan-fold, 1 to 6 part paper maximum forms pack 0.025in Hole spacing: 0.5in centers (nom.) Forms weight: 15lb (first part) 9lb (2'nd - 6'th part) Form crimps: Tab type only

Paper Feed

Pin-feed tractors driven by permanent magnet stepping motor and timing belt
Feed drive rate 4-15deg steps
Tractor adjustment range: 4in to 15in
Vertical line spacing: 0.167in (nom.)
Time for single line feed: 33ms (nom.)
Continuous feed rate: 4.8ips (nom.)

Electrical

Interface	Plug compatible with DGC 20mA current loop and DGC standard EIA voltage interfaces at 300 Baud; Modified 4010 controller (or equiv) recommended for 600 baud operation
Input Power	100, 120 220 240Vac (nominal) 47-63Hz
Power Dissipation	200 Watts (682 BTU/hr)
Power Cable	6ft

Mechanical

Dimensions	33.75in(h) 21in(d) 26.5in(w)
Weight	60lbs (27Kg)

Environmental

Temperature Ranges	Operating: 50degF--104degF (10degC--40degC) Storage/Shipping: -40degF--140degF (-40degC--60degC)
Humidity Ranges	Operating: 10%--90% (non condensing) Storage/Shipping 5%--95% (non condensing)
Maximum Altitude	50,000ft

APPENDIX B CHARACTER SETS

INTRODUCTION

There are six 124-symbol character sets available with standard DGC 6042 and 6043 data terminals, they correspond to standard usage ASCII code specifications in six countries: France, Germany, Japan, Sweden, United Kingdom, and United States. Each character set is shown in its entirety in charts on the pages that follow. All sets are similar to the United States-usage character set; characters variations in each export character set are highlighted in the charts for quick comparison.

Data General's 6042 and 6043 data terminals can print symbols for 124 of the 128 unique, 7-bit (ASCII), codes. The Delete character code, 177₈, is unconditionally ignored by the terminal, and no character is printed for character codes 007₈, 012₈, and 015₈; each of these codes is interpreted by the terminal as a control code, and initiates a specific function at the terminal. (The control functions are audible tone, *Bell*, line feed and carriage return.)

Jumpers positions on the terminal's main logic board allow the terminal to print all 124 characters, or they can be used to alter the action of the terminal's character generator and cause the terminal to ignore certain codes and/or to perform lower-to-upper-case character foldover. (Consult the Installation Data Sheets for 6042 and 6043 terminals: *DGC no. 010-000094*.)

Two character *subsets* may be selected with the jumpers: one restricts the printable character set to 95 symbols, the other restricts it to 64 symbols and enables character foldover.

When the full 124-symbol character set is enabled, the terminal prints ASCII specified symbols for 30 character

codes commonly known as (ASCII) control characters. The symbols that are printed for these 30 codes do not resemble alpha and numeric symbols or punctuation symbols.

95-Character Subset

The 95-character subset includes upper and lower case alpha characters, a blank or space character, punctuation marks, numerals, and certain symbols. The table on the left, below, lists the 30 character codes that are unconditionally ignored by the terminal when the 95-character subset is selected. (The same 30 codes are also ignored when the 64-character subset is selected.)

64-Character Subset

The 64-character subset includes upper case alpha characters, the blank or space character, punctuation marks, numerals and somewhat fewer additional symbols than the 95-character set. Additionally, 31 character codes are translated (character foldover) by the character generator. The translation affects principally lower case alpha character codes, converting them to upper case codes of the same letter *before* printing. Codes for five symbols are also converted to "upper case" equivalents.

Character foldover is accomplished by forcing a zero into bit 2 (from the left) of a 7-bit character code. For example, the following character code conversion, 141₈ → 101₈ causes this alpha character foldover: a → A).

The table on the right, below, lists the 31 character codes translated in the terminal; the character code is shown before and after foldover.

NON PRINTING CONTROL CODES IN 94- and 64-CHARACTER SUBSETS

All character codes are 7-bit, Octal			
000	010	020	030
001	011	021	031
002	012*	022	032
003	013	023	033
004	014	024	034
005	015*	025	035
006	016	026	036
007*	017	027	037
			177

*designates control character

CHARACTER FOLDOVER IN 64-CHARACTER SUBSETS

All character codes are 7-bit, Octal		
140→100	152→112	165→125
141→101	153→113	166→126
142→102	154→114	167→127
143→103	155→115	170→130
144→104	156→116	171→131
145→105	157→117	172→132
146→106	160→120	173→133
147→107	161→121	174→134
150→110	162→122	175→135
151→111	163→123	176→136
	164→124	

Data General Corporation (DGC) has prepared this manual for use by DGC personnel and customers as a guide to the proper installation, operation, and maintenance of DGC equipment and software. The drawings and specifications contained herein are the property of DGC and shall neither be reproduced in whole or in part without DGC's prior written approval nor be implied to grant any license to make, use, or sell equipment manufactured in accordance herewith.

UNITED STATES USAGE

000 ₈ 00 ₁₆ 	001 ₈ 01 ₁₆ 	002 ₈ 02 ₁₆ 	003 ₈ 03 ₁₆ 	004 ₈ 04 ₁₆ 	005 ₈ 05 ₁₆ 	006 ₈ 06 ₁₆ 	007 ₈ 07 ₁₆
010 ₈ 08 ₁₆ 	011 ₈ 09 ₁₆ 	012 ₈ 0A ₁₆ 	013 ₈ 0B ₁₆ 	014 ₈ 0C ₁₆ 	015 ₈ 0D ₁₆ 	016 ₈ 0E ₁₆ 	017 ₈ 0F ₁₆
020 ₈ 10 ₁₆ 	021 ₈ 11 ₁₆ 	022 ₈ 12 ₁₆ 	023 ₈ 13 ₁₆ 	024 ₈ 14 ₁₆ 	025 ₈ 15 ₁₆ 	026 ₈ 16 ₁₆ 	027 ₈ 17 ₁₆
030 ₈ 18 ₁₆ 	031 ₈ 19 ₁₆ 	032 ₈ 1A ₁₆ 	033 ₈ 1B ₁₆ 	034 ₈ 1C ₁₆ 	035 ₈ 1D ₁₆ 	036 ₈ 1E ₁₆ 	037 ₈ 1F ₁₆
040 ₈ 20 ₁₆ 	041 ₈ 21 ₁₆ 	042 ₈ 22 ₁₆ 	043 ₈ 23 ₁₆ 	044 ₈ 24 ₁₆ 	045 ₈ 25 ₁₆ 	046 ₈ 26 ₁₆ 	047 ₈ 27 ₁₆
050 ₈ 28 ₁₆ 	051 ₈ 29 ₁₆ 	052 ₈ 2A ₁₆ 	053 ₈ 2B ₁₆ 	054 ₈ 2C ₁₆ 	055 ₈ 2D ₁₆ 	056 ₈ 2E ₁₆ 	057 ₈ 2F ₁₆
060 ₈ 30 ₁₆ 	061 ₈ 31 ₁₆ 	062 ₈ 32 ₁₆ 	063 ₈ 33 ₁₆ 	064 ₈ 34 ₁₆ 	065 ₈ 35 ₁₆ 	066 ₈ 36 ₁₆ 	067 ₈ 37 ₁₆
070 ₈ 38 ₁₆ 	071 ₈ 39 ₁₆ 	072 ₈ 3A ₁₆ 	073 ₈ 3B ₁₆ 	074 ₈ 3C ₁₆ 	075 ₈ 3D ₁₆ 	076 ₈ 3E ₁₆ 	077 ₈ 3F ₁₆

DG-02786

Data General Corporation (DGC) has prepared this manual for use by DGC personnel and customers as a guide to the proper installation, operation, and maintenance of DGC equipment and software. The drawings and specifications contained herein are the property of DGC and shall neither be reproduced in whole or in part without DGC's prior written approval nor be implied to grant any license to make, use, or sell equipment manufactured in accordance herewith.

UNITED STATES USAGE (Continued)

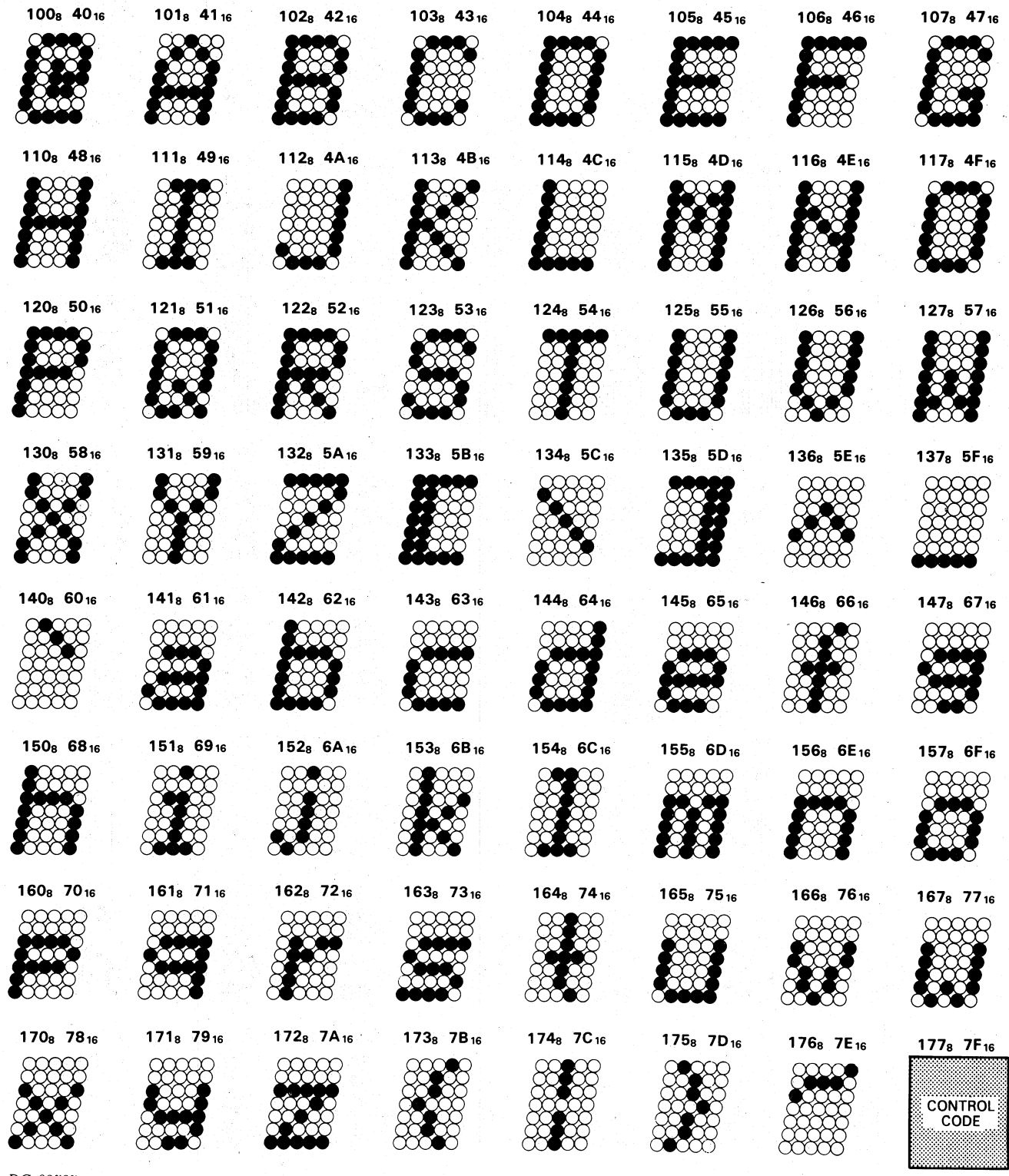









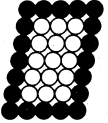
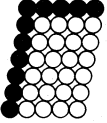
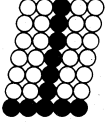
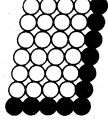
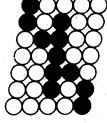
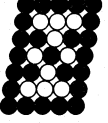
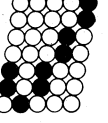

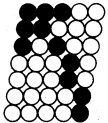
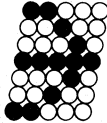
CONTROL CODE

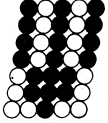
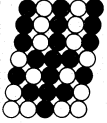
DG-02787

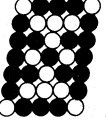
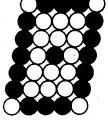
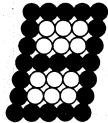
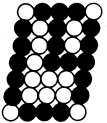
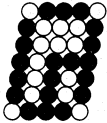
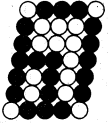
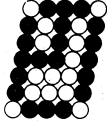
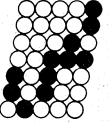
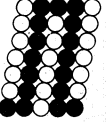
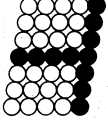
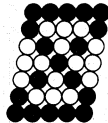
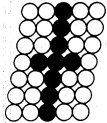
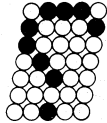
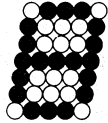
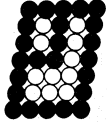
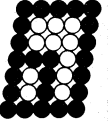
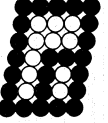
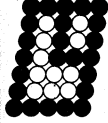
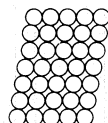
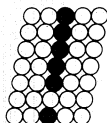
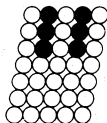
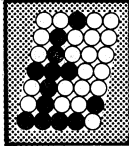
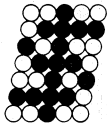
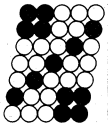
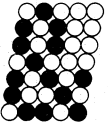
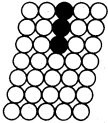
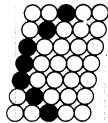
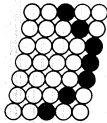
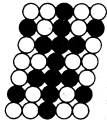
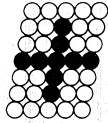
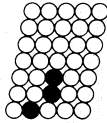
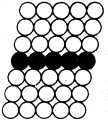
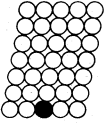
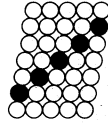
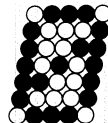
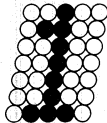
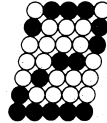
Data General Corporation (DGC) has prepared this manual for use by DGC personnel and customers as a guide to the proper installation, operation, and maintenance of DGC equipment and software. The drawings and specifications contained herein are the property of DGC and shall neither be reproduced in whole or in part without DGC's prior written approval nor be implied to grant any license to make, use, or sell equipment manufactured in accordance herewith.

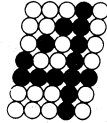
UNITED KINGDOM USAGE

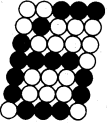
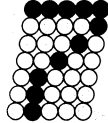
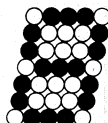
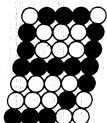
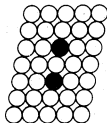
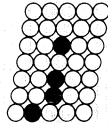
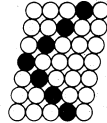
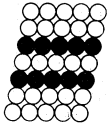
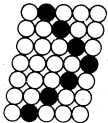
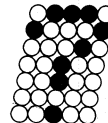
000 ₈ 00 ₁₆ 	001 ₈ 01 ₁₆ 	002 ₈ 02 ₁₆ 	003 ₈ 03 ₁₆ 	004 ₈ 04 ₁₆ 	005 ₈ 05 ₁₆ 	006 ₈ 06 ₁₆ 	007 ₈ 07 ₁₆ 
010 ₈ 08 ₁₆ 	011 ₈ 09 ₁₆ 	012 ₈ 0A ₁₆ 	013 ₈ 0B ₁₆ 	014 ₈ 0C ₁₆ 	015 ₈ 0D ₁₆ 	016 ₈ 0E ₁₆ 	017 ₈ 0F ₁₆ 
020 ₈ 10 ₁₆ 	021 ₈ 11 ₁₆ 	022 ₈ 12 ₁₆ 	023 ₈ 13 ₁₆ 	024 ₈ 14 ₁₆ 	025 ₈ 15 ₁₆ 	026 ₈ 16 ₁₆ 	027 ₈ 17 ₁₆ 
030 ₈ 18 ₁₆ 	031 ₈ 19 ₁₆ 	032 ₈ 1A ₁₆ 	033 ₈ 1B ₁₆ 	034 ₈ 1C ₁₆ 	035 ₈ 1D ₁₆ 	036 ₈ 1E ₁₆ 	037 ₈ 1F ₁₆ 
040 ₈ 20 ₁₆ 	041 ₈ 21 ₁₆ 	042 ₈ 22 ₁₆ 	043 ₈ 23 ₁₆ 	044 ₈ 24 ₁₆ 	045 ₈ 25 ₁₆ 	046 ₈ 26 ₁₆ 	047 ₈ 27 ₁₆ 
050 ₈ 28 ₁₆ 	051 ₈ 29 ₁₆ 	052 ₈ 2A ₁₆ 	053 ₈ 2B ₁₆ 	054 ₈ 2C ₁₆ 	055 ₈ 2D ₁₆ 	056 ₈ 2E ₁₆ 	057 ₈ 2F ₁₆ 
060 ₈ 30 ₁₆ 	061 ₈ 31 ₁₆ 	062 ₈ 32 ₁₆ 	063 ₈ 33 ₁₆ 	064 ₈ 34 ₁₆ 	065 ₈ 35 ₁₆ 	066 ₈ 36 ₁₆ 	067 ₈ 37 ₁₆ 
070 ₈ 38 ₁₆ 	071 ₈ 39 ₁₆ 	072 ₈ 3A ₁₆ 	073 ₈ 3B ₁₆ 	074 ₈ 3C ₁₆ 	075 ₈ 3D ₁₆ 	076 ₈ 3E ₁₆ 	077 ₈ 3F ₁₆ 

DG-02790

UNITED KINGDOM USAGE (Continued)

100 ₈ 40 ₁₆ 	101 ₈ 41 ₁₆ 	102 ₈ 42 ₁₆ 	103 ₈ 43 ₁₆ 	104 ₈ 44 ₁₆ 	105 ₈ 45 ₁₆ 	106 ₈ 46 ₁₆ 	107 ₈ 47 ₁₆
110 ₈ 48 ₁₆ 	111 ₈ 49 ₁₆ 	112 ₈ 4A ₁₆ 	113 ₈ 4B ₁₆ 	114 ₈ 4C ₁₆ 	115 ₈ 4D ₁₆ 	116 ₈ 4E ₁₆ 	117 ₈ 4F ₁₆
120 ₈ 50 ₁₆ 	121 ₈ 51 ₁₆ 	122 ₈ 52 ₁₆ 	123 ₈ 53 ₁₆ 	124 ₈ 54 ₁₆ 	125 ₈ 55 ₁₆ 	126 ₈ 56 ₁₆ 	127 ₈ 57 ₁₆
130 ₈ 58 ₁₆ 	131 ₈ 59 ₁₆ 	132 ₈ 5A ₁₆ 	133 ₈ 5B ₁₆ 	134 ₈ 5C ₁₆ 	135 ₈ 5D ₁₆ 	136 ₈ 5E ₁₆ 	137 ₈ 5F ₁₆
140 ₈ 60 ₁₆ 	141 ₈ 61 ₁₆ 	142 ₈ 62 ₁₆ 	143 ₈ 63 ₁₆ 	144 ₈ 64 ₁₆ 	145 ₈ 65 ₁₆ 	146 ₈ 66 ₁₆ 	147 ₈ 67 ₁₆
150 ₈ 68 ₁₆ 	151 ₈ 69 ₁₆ 	152 ₈ 6A ₁₆ 	153 ₈ 6B ₁₆ 	154 ₈ 6C ₁₆ 	155 ₈ 6D ₁₆ 	156 ₈ 6E ₁₆ 	157 ₈ 6F ₁₆
160 ₈ 70 ₁₆ 	161 ₈ 71 ₁₆ 	162 ₈ 72 ₁₆ 	163 ₈ 73 ₁₆ 	164 ₈ 74 ₁₆ 	165 ₈ 75 ₁₆ 	166 ₈ 76 ₁₆ 	167 ₈ 77 ₁₆
170 ₈ 78 ₁₆ 	171 ₈ 79 ₁₆ 	172 ₈ 7A ₁₆ 	173 ₈ 7B ₁₆ 	174 ₈ 7C ₁₆ 	175 ₈ 7D ₁₆ 	176 ₈ 7E ₁₆ 	177 ₈ 7F ₁₆

DG-02791

Data General Corporation (DGC) has prepared this manual for use by DGC personnel and customers as a guide to the proper installation, operation, and maintenance of DGC equipment and software. The drawings and specifications contained herein are the property of DGC and shall neither be reproduced in whole or in part without DGC's prior written approval nor be implied to grant any license to make, use, or sell equipment manufactured in accordance herewith.

GERMAN USAGE

000 ₈ 00 ₁₆ 	001 ₈ 01 ₁₆ 	002 ₈ 02 ₁₆ 	003 ₈ 03 ₁₆ 	004 ₈ 04 ₁₆ 	005 ₈ 05 ₁₆ 	006 ₈ 06 ₁₆ 	007 ₈ 07 ₁₆
010 ₈ 08 ₁₆ 	011 ₈ 09 ₁₆ 	012 ₈ 0A ₁₆ 	013 ₈ 0B ₁₆ 	014 ₈ 0C ₁₆ 	015 ₈ 0D ₁₆ 	016 ₈ 0E ₁₆ 	017 ₈ 0F ₁₆
020 ₈ 10 ₁₆ 	021 ₈ 11 ₁₆ 	022 ₈ 12 ₁₆ 	023 ₈ 13 ₁₆ 	024 ₈ 14 ₁₆ 	025 ₈ 15 ₁₆ 	026 ₈ 16 ₁₆ 	027 ₈ 17 ₁₆
030 ₈ 18 ₁₆ 	031 ₈ 19 ₁₆ 	032 ₈ 1A ₁₆ 	033 ₈ 1B ₁₆ 	034 ₈ 1C ₁₆ 	035 ₈ 1D ₁₆ 	036 ₈ 1E ₁₆ 	037 ₈ 1F ₁₆
040 ₈ 20 ₁₆ 	041 ₈ 21 ₁₆ 	042 ₈ 22 ₁₆ 	043 ₈ 23 ₁₆ 	044 ₈ 24 ₁₆ 	045 ₈ 25 ₁₆ 	046 ₈ 26 ₁₆ 	047 ₈ 27 ₁₆
050 ₈ 28 ₁₆ 	051 ₈ 29 ₁₆ 	052 ₈ 2A ₁₆ 	053 ₈ 2B ₁₆ 	054 ₈ 2C ₁₆ 	055 ₈ 2D ₁₆ 	056 ₈ 2E ₁₆ 	057 ₈ 2F ₁₆
060 ₈ 30 ₁₆ 	061 ₈ 31 ₁₆ 	062 ₈ 32 ₁₆ 	063 ₈ 33 ₁₆ 	064 ₈ 34 ₁₆ 	065 ₈ 35 ₁₆ 	066 ₈ 36 ₁₆ 	067 ₈ 37 ₁₆
070 ₈ 38 ₁₆ 	071 ₈ 39 ₁₆ 	072 ₈ 3A ₁₆ 	073 ₈ 3B ₁₆ 	074 ₈ 3C ₁₆ 	075 ₈ 3D ₁₆ 	076 ₈ 3E ₁₆ 	077 ₈ 3F ₁₆

DG-02788

GERMAN USAGE (Continued)

100₈ 40₁₆ 	101₈ 41₁₆ 	102₈ 42₁₆ 	103₈ 43₁₆ 	104₈ 44₁₆ 	105₈ 45₁₆ 	106₈ 46₁₆ 	107₈ 47₁₆
110₈ 48₁₆ 	111₈ 49₁₆ 	112₈ 4A₁₆ 	113₈ 4B₁₆ 	114₈ 4C₁₆ 	115₈ 4D₁₆ 	116₈ 4E₁₆ 	117₈ 4F₁₆
120₈ 50₁₆ 	121₈ 51₁₆ 	122₈ 52₁₆ 	123₈ 53₁₆ 	124₈ 54₁₆ 	125₈ 55₁₆ 	126₈ 56₁₆ 	127₈ 57₁₆
130₈ 58₁₆ 	131₈ 59₁₆ 	132₈ 5A₁₆ 	133₈ 5B₁₆ 	134₈ 5C₁₆ 	135₈ 5D₁₆ 	136₈ 5E₁₆ 	137₈ 5F₁₆
140₈ 60₁₆ 	141₈ 61₁₆ 	142₈ 62₁₆ 	143₈ 63₁₆ 	144₈ 64₁₆ 	145₈ 65₁₆ 	146₈ 66₁₆ 	147₈ 67₁₆
150₈ 68₁₆ 	151₈ 69₁₆ 	152₈ 6A₁₆ 	153₈ 6B₁₆ 	154₈ 6C₁₆ 	155₈ 6D₁₆ 	156₈ 6E₁₆ 	157₈ 6F₁₆
160₈ 70₁₆ 	161₈ 71₁₆ 	162₈ 72₁₆ 	163₈ 73₁₆ 	164₈ 74₁₆ 	165₈ 75₁₆ 	166₈ 76₁₆ 	167₈ 77₁₆
170₈ 78₁₆ 	171₈ 79₁₆ 	172₈ 7A₁₆ 	173₈ 7B₁₆ 	174₈ 7C₁₆ 	175₈ 7D₁₆ 	176₈ 7E₁₆ 	177₈ 7F₁₆

DG-02789

Data General Corporation (DGC) has prepared this manual for use by DGC personnel and customers as a guide to the proper installation, operation, and maintenance of DGC equipment and software. The drawings and specifications contained herein are the property of DGC and shall neither be reproduced in whole or in part without DGC's prior written approval nor be implied to grant any license to make, use, or sell equipment manufactured in accordance herewith.







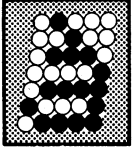
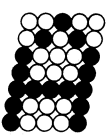
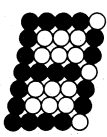
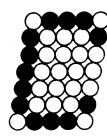
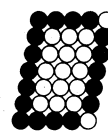

FRENCH USAGE

000 ₈ 00 ₁₆ 	001 ₈ 01 ₁₆ 	002 ₈ 02 ₁₆ 	003 ₈ 03 ₁₆ 	004 ₈ 04 ₁₆ 	005 ₈ 05 ₁₆ 	006 ₈ 06 ₁₆ 	007 ₈ 07 ₁₆
010 ₈ 08 ₁₆ 	011 ₈ 09 ₁₆ 	012 ₈ 0A ₁₆ 	013 ₈ 0B ₁₆ 	014 ₈ 0C ₁₆ 	015 ₈ 0D ₁₆ 	016 ₈ 0E ₁₆ 	017 ₈ 0F ₁₆
020 ₈ 10 ₁₆ 	021 ₈ 11 ₁₆ 	022 ₈ 12 ₁₆ 	023 ₈ 13 ₁₆ 	024 ₈ 14 ₁₆ 	025 ₈ 15 ₁₆ 	026 ₈ 16 ₁₆ 	027 ₈ 17 ₁₆
030 ₈ 18 ₁₆ 	031 ₈ 19 ₁₆ 	032 ₈ 1A ₁₆ 	033 ₈ 1B ₁₆ 	034 ₈ 1C ₁₆ 	035 ₈ 1D ₁₆ 	036 ₈ 1E ₁₆ 	037 ₈ 1F ₁₆
040 ₈ 20 ₁₆ 	041 ₈ 21 ₁₆ 	042 ₈ 22 ₁₆ 	043 ₈ 23 ₁₆ 	044 ₈ 24 ₁₆ 	045 ₈ 25 ₁₆ 	046 ₈ 26 ₁₆ 	047 ₈ 27 ₁₆
050 ₈ 28 ₁₆ 	051 ₈ 29 ₁₆ 	052 ₈ 2A ₁₆ 	053 ₈ 2B ₁₆ 	054 ₈ 2C ₁₆ 	055 ₈ 2D ₁₆ 	056 ₈ 2E ₁₆ 	057 ₈ 2F ₁₆
060 ₈ 30 ₁₆ 	061 ₈ 31 ₁₆ 	062 ₈ 32 ₁₆ 	063 ₈ 33 ₁₆ 	064 ₈ 34 ₁₆ 	065 ₈ 35 ₁₆ 	066 ₈ 36 ₁₆ 	067 ₈ 37 ₁₆
070 ₈ 38 ₁₆ 	071 ₈ 39 ₁₆ 	072 ₈ 3A ₁₆ 	073 ₈ 3B ₁₆ 	074 ₈ 3C ₁₆ 	075 ₈ 3D ₁₆ 	076 ₈ 3E ₁₆ 	077 ₈ 3F ₁₆

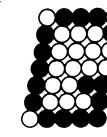
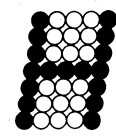
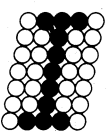
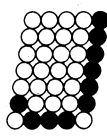
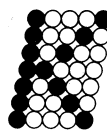
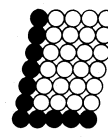
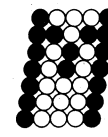
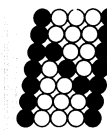
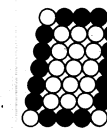
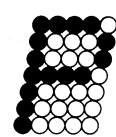
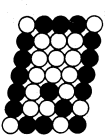
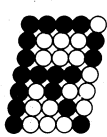
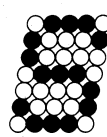
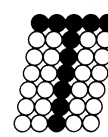
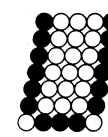
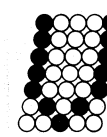
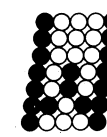
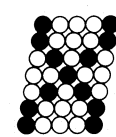
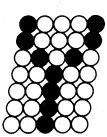
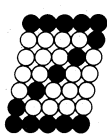
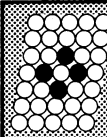
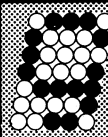
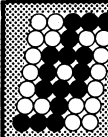
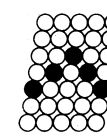
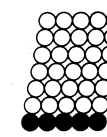
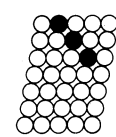
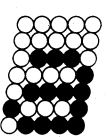
DG-02792

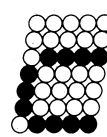
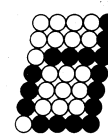
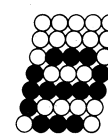
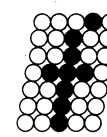
Data General Corporation (DGC) has prepared this manual for use by DGC personnel and customers as a guide to the proper installation, operation, and maintenance of DGC equipment and software. The drawings and specifications contained herein are the property of DGC and shall neither be reproduced in whole or in part without DGC's prior written approval nor be implied to grant any license to make, use, or sell equipment manufactured in accordance herewith.

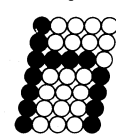
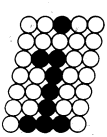
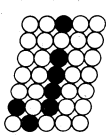
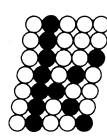
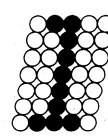
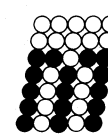
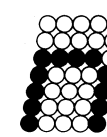
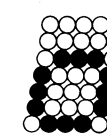
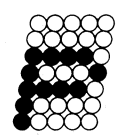
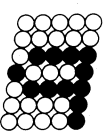
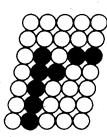
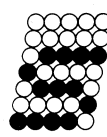
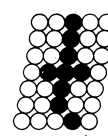
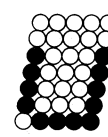
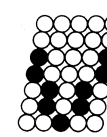
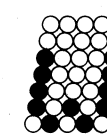
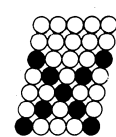
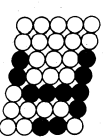
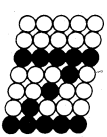
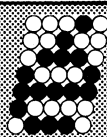
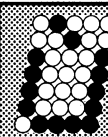
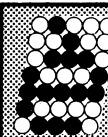
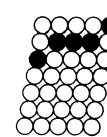
FRENCH USAGE (Continued)

 100 ₈ 40 ₁₆	 101 ₈ 41 ₁₆	 102 ₈ 42 ₁₆	 103 ₈ 43 ₁₆	 104 ₈ 44 ₁₆	 105 ₈ 45 ₁₆	 106 ₈ 46 ₁₆	 107 ₈ 47 ₁₆
 110 ₈ 48 ₁₆	 111 ₈ 49 ₁₆	 112 ₈ 4A ₁₆	 113 ₈ 4B ₁₆	 114 ₈ 4C ₁₆	 115 ₈ 4D ₁₆	 116 ₈ 4E ₁₆	 117 ₈ 4F ₁₆
 120 ₈ 50 ₁₆	 121 ₈ 51 ₁₆	 122 ₈ 5A ₁₆	 123 ₈ 5B ₁₆	 124 ₈ 54 ₁₆	 125 ₈ 55 ₁₆	 126 ₈ 56 ₁₆	 127 ₈ 57 ₁₆
 130 ₈ 58 ₁₆	 131 ₈ 59 ₁₆	 132 ₈ 5A ₁₆	 133 ₈ 5B ₁₆	 134 ₈ 5C ₁₆	 135 ₈ 5D ₁₆	 136 ₈ 5E ₁₆	 137 ₈ 5F ₁₆
 140 ₈ 60 ₁₆	 141 ₈ 61 ₁₆	 142 ₈ 62 ₁₆	 143 ₈ 63 ₁₆	 144 ₈ 64 ₁₆	 145 ₈ 65 ₁₆	 146 ₈ 66 ₁₆	 147 ₈ 67 ₁₆
 150 ₈ 68 ₁₆	 151 ₈ 69 ₁₆	 152 ₈ 6A ₁₆	 153 ₈ 6B ₁₆	 154 ₈ 6C ₁₆	 155 ₈ 6D ₁₆	 156 ₈ 6E ₁₆	 157 ₈ 6F ₁₆
 160 ₈ 70 ₁₆	 161 ₈ 71 ₁₆	 162 ₈ 72 ₁₆	 163 ₈ 73 ₁₆	 164 ₈ 74 ₁₆	 165 ₈ 75 ₁₆	 166 ₈ 76 ₁₆	 167 ₈ 77 ₁₆
 170 ₈ 78 ₁₆	 171 ₈ 79 ₁₆	 172 ₈ 7A ₁₆	 173 ₈ 7B ₁₆	 174 ₈ 7C ₁₆	 175 ₈ 7D ₁₆	 176 ₈ 7E ₁₆	 177 ₈ 7F ₁₆

DG-02793

Data General Corporation (DGC) has prepared this manual for use by DGC personnel and customers as a guide to the proper installation, operation, and maintenance of DGC equipment and software. The drawings and specifications contained herein are the property of DGC and shall neither be reproduced in whole or in part without DGC's prior written approval nor be implied to grant any license to make, use, or sell equipment manufactured in accordance herewith.

SWEDISH USAGE

000 ₈ 00 ₁₆ 	001 ₈ 01 ₁₆ 	002 ₈ 02 ₁₆ 	003 ₈ 03 ₁₆ 	004 ₈ 04 ₁₆ 	005 ₈ 05 ₁₆ 	006 ₈ 06 ₁₆ 	007 ₈ 07 ₁₆
010 ₈ 08 ₁₆ 	011 ₈ 09 ₁₆ 	012 ₈ 0A ₁₆ 	013 ₈ 0B ₁₆ 	014 ₈ 0C ₁₆ 	015 ₈ 0D ₁₆ 	016 ₈ 0E ₁₆ 	017 ₈ 0F ₁₆
020 ₈ 10 ₁₆ 	021 ₈ 11 ₁₆ 	022 ₈ 12 ₁₆ 	023 ₈ 13 ₁₆ 	024 ₈ 14 ₁₆ 	025 ₈ 15 ₁₆ 	026 ₈ 16 ₁₆ 	027 ₈ 17 ₁₆
030 ₈ 18 ₁₆ 	031 ₈ 19 ₁₆ 	032 ₈ 1A ₁₆ 	033 ₈ 1B ₁₆ 	034 ₈ 1C ₁₆ 	035 ₈ 1D ₁₆ 	036 ₈ 1E ₁₆ 	037 ₈ 1F ₁₆
040 ₈ 20 ₁₆ 	041 ₈ 21 ₁₆ 	042 ₈ 22 ₁₆ 	043 ₈ 23 ₁₆ 	044 ₈ 24 ₁₆ 	045 ₈ 25 ₁₆ 	046 ₈ 26 ₁₆ 	047 ₈ 27 ₁₆
050 ₈ 28 ₁₆ 	051 ₈ 29 ₁₆ 	052 ₈ 2A ₁₆ 	053 ₈ 2B ₁₆ 	054 ₈ 2C ₁₆ 	055 ₈ 2D ₁₆ 	056 ₈ 2E ₁₆ 	057 ₈ 2F ₁₆
060 ₈ 30 ₁₆ 	061 ₈ 31 ₁₆ 	062 ₈ 32 ₁₆ 	063 ₈ 33 ₁₆ 	064 ₈ 34 ₁₆ 	065 ₈ 35 ₁₆ 	066 ₈ 36 ₁₆ 	067 ₈ 37 ₁₆
070 ₈ 38 ₁₆ 	071 ₈ 39 ₁₆ 	072 ₈ 3A ₁₆ 	073 ₈ 3B ₁₆ 	074 ₈ 3C ₁₆ 	075 ₈ 3D ₁₆ 	076 ₈ 3E ₁₆ 	077 ₈ 3F ₁₆

DG-02796

SWEDISH USAGE (Continued)







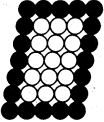
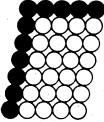
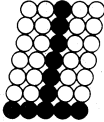
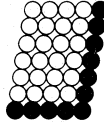
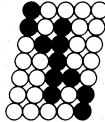
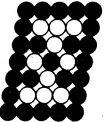
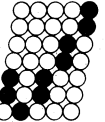

100 ₈ 40 ₁₆ 	101 ₈ 41 ₁₆ 	102 ₈ 42 ₁₆ 	103 ₈ 43 ₁₆ 	104 ₈ 44 ₁₆ 	105 ₈ 45 ₁₆ 	106 ₈ 46 ₁₆ 	107 ₈ 47 ₁₆
110 ₈ 48 ₁₆ 	111 ₈ 49 ₁₆ 	112 ₈ 4A ₁₆ 	113 ₈ 4B ₁₆ 	114 ₈ 4C ₁₆ 	115 ₈ 4D ₁₆ 	116 ₈ 4E ₁₆ 	117 ₈ 4F ₁₆
120 ₈ 50 ₁₆ 	121 ₈ 51 ₁₆ 	122 ₈ 52 ₁₆ 	123 ₈ 53 ₁₆ 	124 ₈ 54 ₁₆ 	125 ₈ 55 ₁₆ 	126 ₈ 56 ₁₆ 	127 ₈ 57 ₁₆
130 ₈ 58 ₁₆ 	131 ₈ 59 ₁₆ 	132 ₈ 5A ₁₆ 	133 ₈ 5B ₁₆ 	134 ₈ 5C ₁₆ 	135 ₈ 5D ₁₆ 	136 ₈ 5E ₁₆ 	137 ₈ 5F ₁₆
140 ₈ 60 ₁₆ 	141 ₈ 61 ₁₆ 	142 ₈ 62 ₁₆ 	143 ₈ 63 ₁₆ 	144 ₈ 64 ₁₆ 	145 ₈ 65 ₁₆ 	146 ₈ 66 ₁₆ 	147 ₈ 67 ₁₆
150 ₈ 68 ₁₆ 	151 ₈ 69 ₁₆ 	152 ₈ 6A ₁₆ 	153 ₈ 6B ₁₆ 	154 ₈ 6C ₁₆ 	155 ₈ 6D ₁₆ 	156 ₈ 6E ₁₆ 	157 ₈ 6F ₁₆
160 ₈ 70 ₁₆ 	161 ₈ 71 ₁₆ 	162 ₈ 72 ₁₆ 	163 ₈ 73 ₁₆ 	164 ₈ 74 ₁₆ 	165 ₈ 75 ₁₆ 	166 ₈ 76 ₁₆ 	167 ₈ 77 ₁₆
170 ₈ 78 ₁₆ 	171 ₈ 79 ₁₆ 	172 ₈ 7A ₁₆ 	173 ₈ 7B ₁₆ 	174 ₈ 7C ₁₆ 	175 ₈ 7D ₁₆ 	176 ₈ 7E ₁₆ 	177 ₈ 7F ₁₆

DG-02797

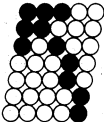
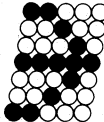
CONTROL
CODE

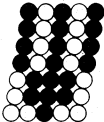
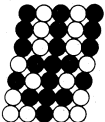
Data General Corporation (DGC) has prepared this manual for use by DGC personnel and customers as a guide to the proper installation, operation, and maintenance of DGC equipment and software. The drawings and specifications contained herein are the property of DGC and shall neither be reproduced in whole or in part without DGC's prior written approval nor be implied to grant any license to make, use, or sell equipment manufactured in accordance herewith.

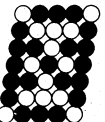
JAPANESE USAGE

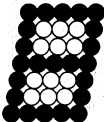
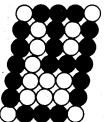
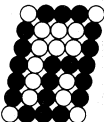
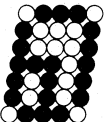
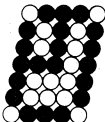
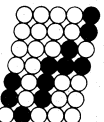
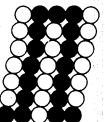
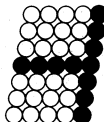
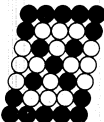
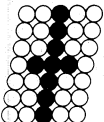
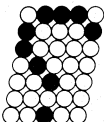
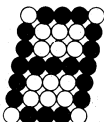
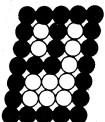
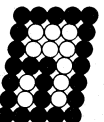
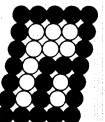
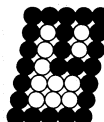
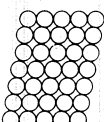
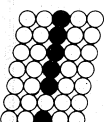
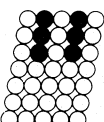
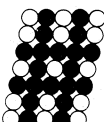
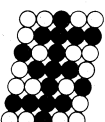
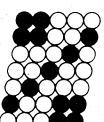
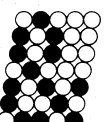
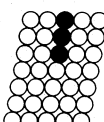
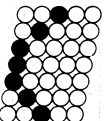
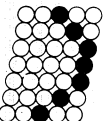
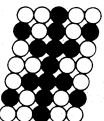
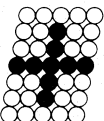
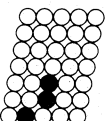
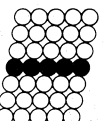
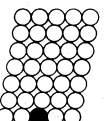
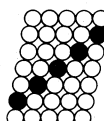
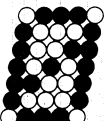
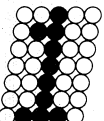
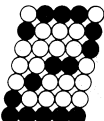
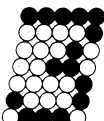
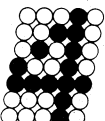
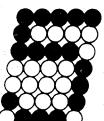
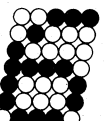
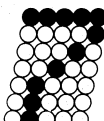
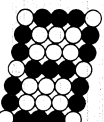
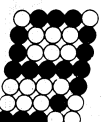
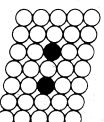
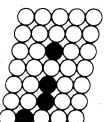
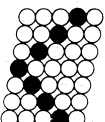
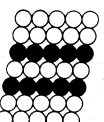
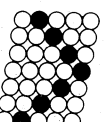
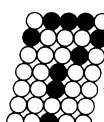
000 ₈ 00 ₁₆ 	001 ₈ 01 ₁₆ 	002 ₈ 02 ₁₆ 	003 ₈ 03 ₁₆ 	004 ₈ 04 ₁₆ 	005 ₈ 05 ₁₆ 	006 ₈ 06 ₁₆ 	007 ₈ 07 ₁₆ 
010 ₈ 08 ₁₆ 	011 ₈ 09 ₁₆ 	012 ₈ 0A ₁₆ 	013 ₈ 0B ₁₆ 	014 ₈ 0C ₁₆ 	015 ₈ 0D ₁₆ 	016 ₈ 0E ₁₆ 	017 ₈ 0F ₁₆ 
020 ₈ 10 ₁₆ 	021 ₈ 11 ₁₆ 	022 ₈ 12 ₁₆ 	023 ₈ 13 ₁₆ 	024 ₈ 14 ₁₆ 	025 ₈ 15 ₁₆ 	026 ₈ 16 ₁₆ 	027 ₈ 17 ₁₆ 
030 ₈ 18 ₁₆ 	031 ₈ 19 ₁₆ 	032 ₈ 1A ₁₆ 	033 ₈ 1B ₁₆ 	034 ₈ 1C ₁₆ 	035 ₈ 1D ₁₆ 	036 ₈ 1E ₁₆ 	037 ₈ 1F ₁₆ 
040 ₈ 20 ₁₆ 	041 ₈ 21 ₁₆ 	042 ₈ 22 ₁₆ 	043 ₈ 23 ₁₆ 	044 ₈ 24 ₁₆ 	045 ₈ 25 ₁₆ 	046 ₈ 26 ₁₆ 	047 ₈ 27 ₁₆ 
050 ₈ 28 ₁₆ 	051 ₈ 29 ₁₆ 	052 ₈ 2A ₁₆ 	053 ₈ 2B ₁₆ 	054 ₈ 2C ₁₆ 	055 ₈ 2D ₁₆ 	056 ₈ 2E ₁₆ 	057 ₈ 2F ₁₆ 
060 ₈ 30 ₁₆ 	061 ₈ 31 ₁₆ 	062 ₈ 32 ₁₆ 	063 ₈ 33 ₁₆ 	064 ₈ 34 ₁₆ 	065 ₈ 35 ₁₆ 	066 ₈ 36 ₁₆ 	067 ₈ 37 ₁₆ 
070 ₈ 38 ₁₆ 	071 ₈ 39 ₁₆ 	072 ₈ 3A ₁₆ 	073 ₈ 3B ₁₆ 	074 ₈ 3C ₁₆ 	075 ₈ 3D ₁₆ 	076 ₈ 3E ₁₆ 	077 ₈ 3F ₁₆ 

DG-0279-1

Data General Corporation (DGC) has prepared this manual for use by DGC personnel and customers as a guide to the proper installation, operation, and maintenance of DGC equipment and software. The drawings and specifications contained herein are the property of DGC and shall neither be reproduced in whole or in part without DGC's prior written approval nor be implied to grant any license to make, use, or sell equipment manufactured in accordance herewith.

JAPANESE USAGE (Continued)

100 ₈ 40 ₁₆ 	101 ₈ 41 ₁₆ 	102 ₈ 42 ₁₆ 	103 ₈ 43 ₁₆ 	104 ₈ 44 ₁₆ 	105 ₈ 45 ₁₆ 	106 ₈ 46 ₁₆ 	107 ₈ 47 ₁₆
110 ₈ 48 ₁₆ 	111 ₈ 49 ₁₆ 	112 ₈ 4A ₁₆ 	113 ₈ 4B ₁₆ 	114 ₈ 4C ₁₆ 	115 ₈ 4D ₁₆ 	116 ₈ 4E ₁₆ 	117 ₈ 4F ₁₆
120 ₈ 50 ₁₆ 	121 ₈ 51 ₁₆ 	122 ₈ 52 ₁₆ 	123 ₈ 53 ₁₆ 	124 ₈ 54 ₁₆ 	125 ₈ 55 ₁₆ 	126 ₈ 56 ₁₆ 	127 ₈ 57 ₁₆
130 ₈ 58 ₁₆ 	131 ₈ 59 ₁₆ 	132 ₈ 5A ₁₆ 	133 ₈ 5B ₁₆ 	134 ₈ 5C ₁₆ 	135 ₈ 5D ₁₆ 	136 ₈ 5E ₁₆ 	137 ₈ 5F ₁₆
140 ₈ 60 ₁₆ 	141 ₈ 61 ₁₆ 	142 ₈ 62 ₁₆ 	143 ₈ 63 ₁₆ 	144 ₈ 64 ₁₆ 	145 ₈ 65 ₁₆ 	146 ₈ 66 ₁₆ 	147 ₈ 67 ₁₆
150 ₈ 68 ₁₆ 	151 ₈ 69 ₁₆ 	152 ₈ 6A ₁₆ 	153 ₈ 6B ₁₆ 	154 ₈ 6C ₁₆ 	155 ₈ 6D ₁₆ 	156 ₈ 6E ₁₆ 	157 ₈ 6F ₁₆
160 ₈ 70 ₁₆ 	161 ₈ 71 ₁₆ 	162 ₈ 72 ₁₆ 	163 ₈ 73 ₁₆ 	164 ₈ 74 ₁₆ 	165 ₈ 75 ₁₆ 	166 ₈ 76 ₁₆ 	167 ₈ 77 ₁₆
170 ₈ 78 ₁₆ 	171 ₈ 79 ₁₆ 	172 ₈ 7A ₁₆ 	173 ₈ 7B ₁₆ 	174 ₈ 7C ₁₆ 	175 ₈ 7D ₁₆ 	176 ₈ 7E ₁₆ 	177 ₈ 7F ₁₆

DG-02795

Data General Corporation (DGC) has prepared this manual for use by DGC personnel and customers as a guide to the proper installation, operation, and maintenance of DGC equipment and software. The drawings and specifications contained herein are the property of DGC and shall neither be reproduced in whole or in part without DGC's prior written approval nor be implied to grant any license to make, use, or sell equipment manufactured in accordance herewith.

This page intentionally left blank.



