

INSTALLATION SPECIFICATIONS

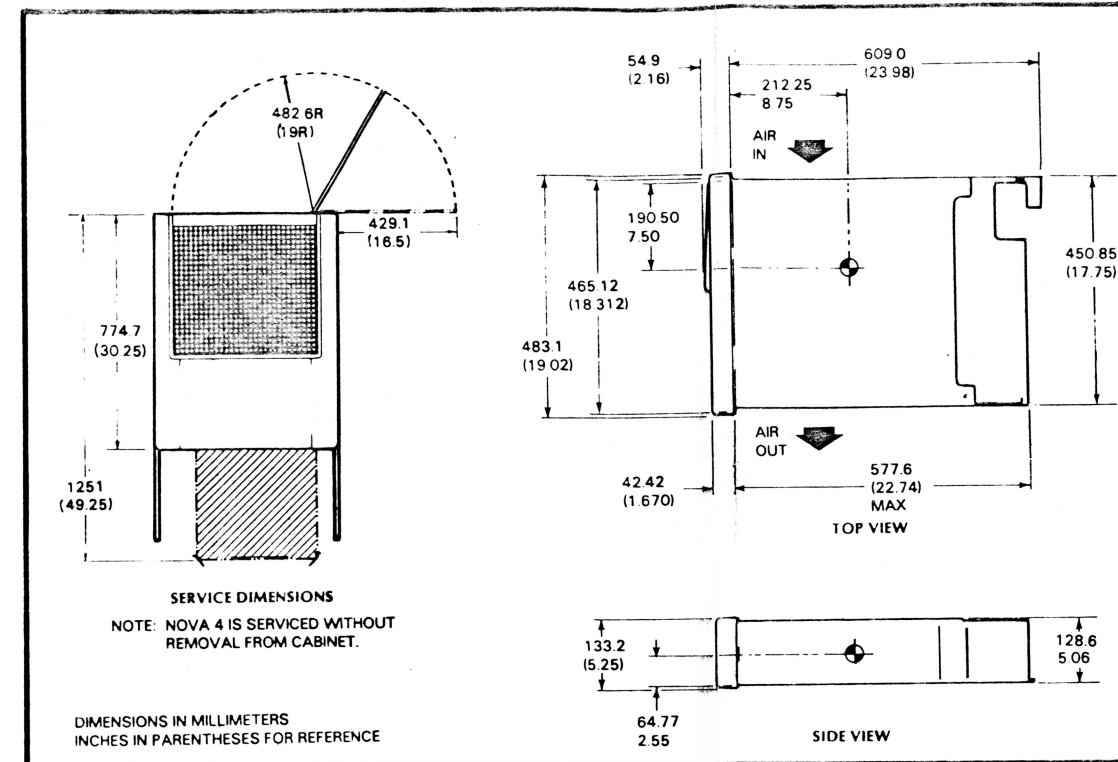
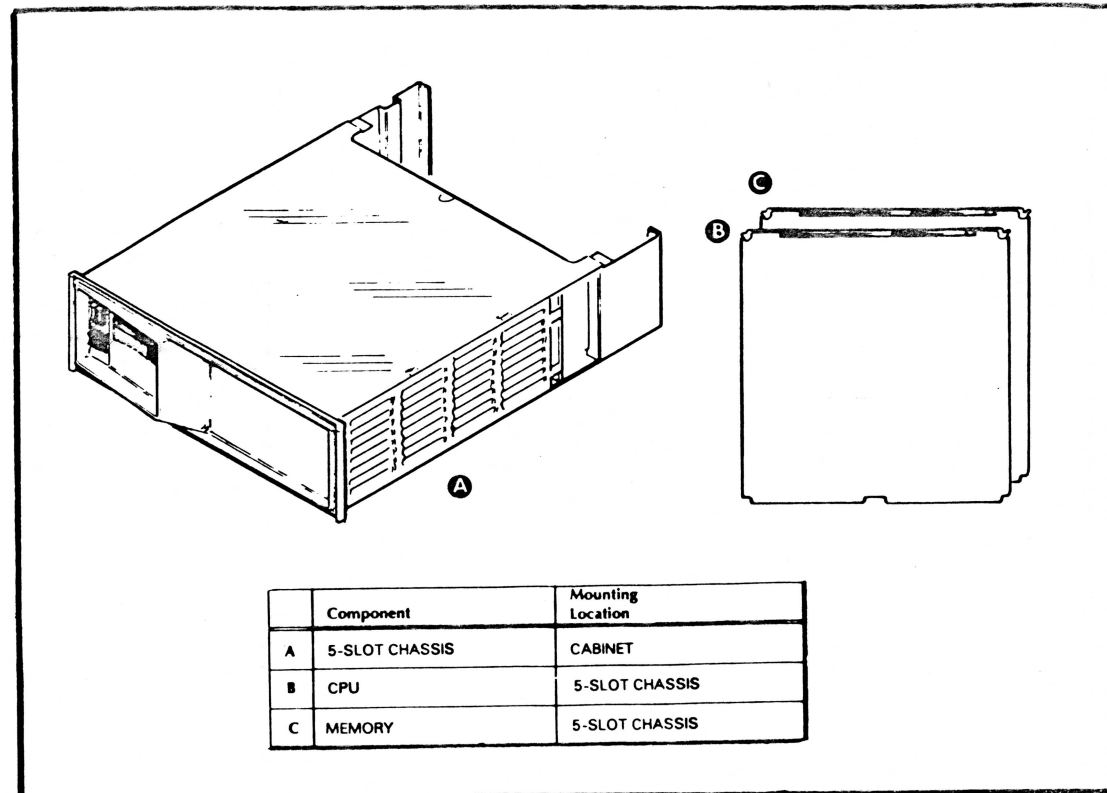

SLOT ASSIGNMENTS

Slot	Data Channel Speeds Available		+5V Current Draw
	Allowed (Slot Chart)	Assigned	
5	I/O		
4	I/O		
3	I/O		
2	MEMORY or I/O		NOTE 2
1	CPU		NOTE 1
0	POWER SUPPLY		

Standard High Speed
 High Speed

Total +5V Current draw
Max +5 Current Available
+5 Current Surplus 35A

- NOTES:**
1. NOVA 4/S and NOVA 4/X NOVA 4/C 17A
8A
 2. MEMORY (NOVA 4/S & 4/X only) 5.6A
 3. PUSH ON TERMINATORS ON MEMORY SLOT (NOVA 4/S & 4/X ONLY)
 4. MAX DRAW +15V, +12V, +12V MEM 5.0A
 5. MAX DRAW -5V, -5V MEM 1.5A

SPECIFICATIONS		NOVA 4 5-slot		HEAT OUTPUT: 400 watts (1365 BTU/hr)	
DIMENSIONS:	Width	Depth	Height	POWER REQUIREMENTS:	
Millimeters	483.1	663.9	133.2	(Domestic)	
Inches	19.02	26.14	5.25	Voltage	85-132
SERVICE CLEARANCES:	Front			Hz	47-63
Millimeters	508.0			Max Amp per Phase	6.0
Inches	20.0			Phase	1
WEIGHT:	Empty	Fully Loaded		(Export)	
Kilograms	18.14	22.68		Voltage	187-264
Pounds	40	50		Hz	47-63
OPERATING ENVIRONMENT:				Max Amp per Phase	3.5
Temperature (max)	55°C (131°F) 60Hz			Phase	1
Relative Humidity (max)	45°C (113°F) 50Hz			LINE CORDS:	
Altitude (max)	3084m (10,000')			Supply	Part No.
CABLES:	Length	Conn	Mating Conn	100V	109 000239
Primary Power				120V	109 000238
Domestic	1.8m(6')	5-15P	5-15R	220V	109 000237
Export	1.8m(6')	6-15P	6-15R	240V	109 000240
External I/O Bus Cable	15.3m (50') max				

013-000840
BRUNING 40-526 27928

THIS DRAWING AND SPECIFICATIONS HEREIN ARE THE PROPERTY OF DATA GENERAL CORPORATION AND SHALL NOT BE REPRODUCED OR COPIED OR USED IN WHOLE OR IN PART AS THE BASIS FOR MANUFACTURE OR SALE OF ITEMS WITHOUT WRITTEN PERMISSION.

REV	1	2	3	4	5	6	7	8	9	10	11	12	13	14	15	16	17	18	19	20
ECO	1/12	FEK	FBBS	1/5/1																
APP																				
DATE	2/25	4/17/71	1/1/72																	

DRAWN	APPROVED
CHECKED	FIRST USED ON
ENGINEER	CODE IDENT 34984

TITLE
INSTALLATION DATA SHEET
NOVA 4 5-SLOT

DATA GENERAL CORPORATION			
WESTBORO MASSACHUSETTS 01581			
SIZE	CODE	DRAWING NUMBER	REV
C	010	000212	03

SHIPPING

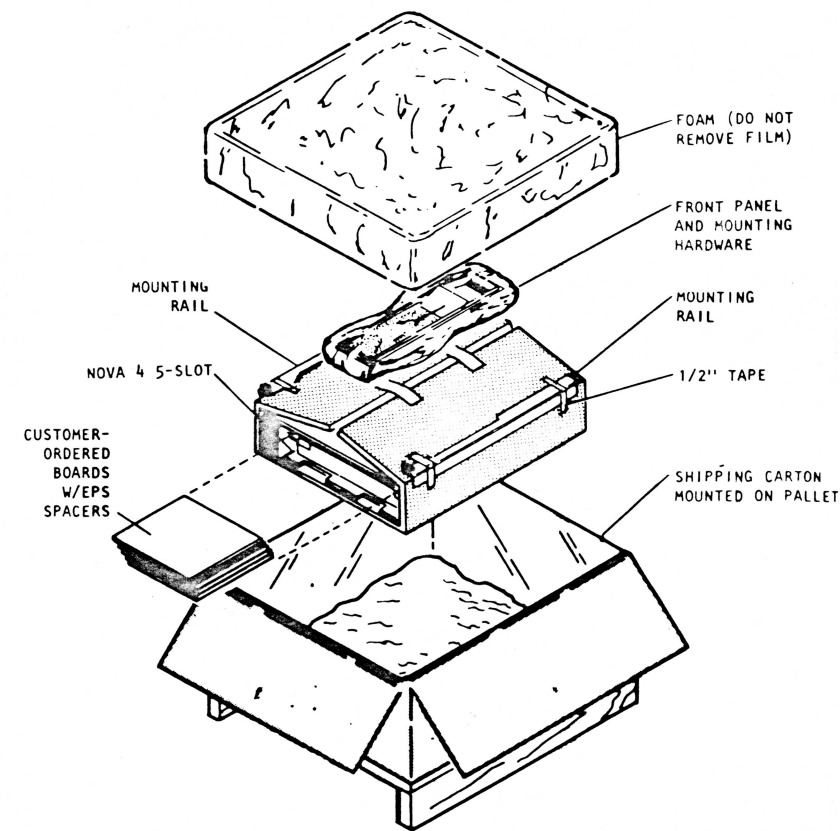

DG-08726

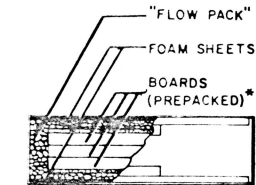
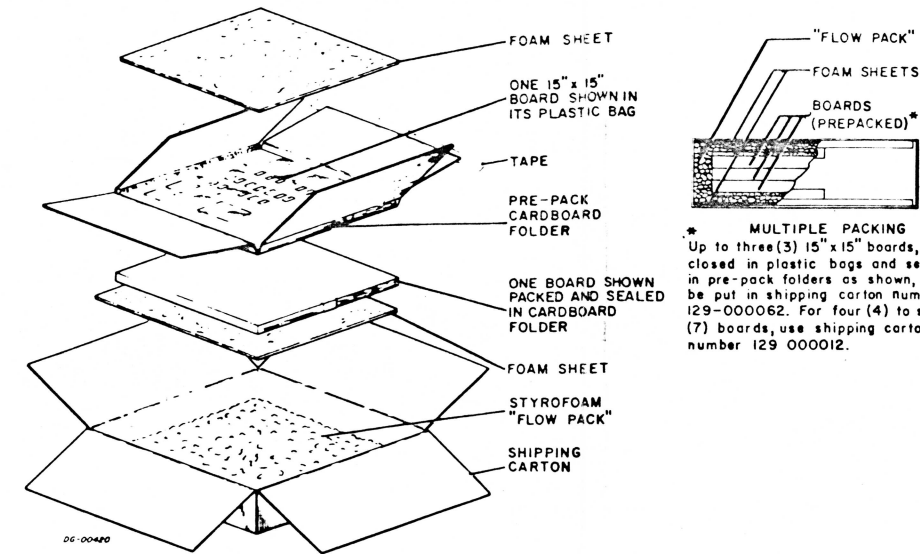

* MULTIPLE PACKING
Up to three (3) 15" x 15" boards, enclosed in plastic bags and sealed in pre-pack folders as shown, can be put in shipping carton number 129-00062. For four (4) to seven (7) boards, use shipping carton number 129 00012.

SHIPPING AND PACKAGE DATA					
Outside Dimensions			Weight (Gross)	Volume	Density
Length	Width	Depth			
in.	in.	in.	lbs.	cu ft.	lbs/cu ft.
cm	cm	cm	kg	cu m	kg/cu m
36	28	24.5	75	14.29	
91.4	71.12	62.2	34.01	.4287	
SHIPPING SPECIFICATIONS			STORAGE SPECIFICATIONS		
Temperature Range	Relative Humidity	Maximum Altitude	Temperature Range	Relative Humidity	Maximum Period
°F	(Non-condensing)		°F	(Non-condensing)	
°C			°C		
-40to+160	0%/90%	50,000ft. 15,200m	-40to+160	0%/90%	90 days
-40to+71			-40to+71		

DG-03224

013-000840
BRUNING 40-526 2792B

THIS DRAWING AND SPECIFICATIONS, HEREIN, ARE THE PROPERTY OF DATA GENERAL CORPORATION, AND SHALL NOT BE REPRODUCED OR COPIED OR USED IN WHOLE OR IN PART AS THE BASIS FOR MANUFACTURE OR SALE OF ITEMS WITHOUT WRITTEN PERMISSION

REV	DATE	APP	ECO

DRAWN	ENGINEER	APPROVED	CODE IDENT
			34984

TITLE
INSTALLATION DATA SHEET
NOVA 4 5-SLOT

DATA GENERAL CORPORATION			
WESTBORO, MASSACHUSETTS 01581			
SIZE	CODE	DRAWING NUMBER	REV
C	010	000212	03

TAILORING CPU JUMPERING NOVA 4/C

DEVICE CODE JUMPERS FOR FRONT PANEL AUTOMATIC PROGRAM LOAD
SELECT THE PROGRAM LOAD DEVICE CODE BY INSTALLING JUMPERS
W11, W8, W6, W7, W9, W10, AS FOLLOWS:

JUMPER OUT = 1 JUMPER IN = 0

EXAMPLE JUMPERING FOR DEVICE CODE 278:

W11	W8	W6	W7	W9	W10
IN	OUT	IN	OUT	OUT	OUT

W4 IS NOT INSERTED IF THE PROGRAM LOAD DEVICE IS A HIGH SPEED DEVICE, OTHERWISE IT IS INSERTED.

TYPE OF TRANSMISSION JUMPERS

TYPE OF TRANSMISSION	JUMPERS INSERTED*
20MA CURRENT LOOP	W1, W3
EIA RS232-C	W2

* JUMPER 25 IS INSERTED IF THE SYSTEM TERMINAL IS A TELETYPE, OTHERWISE IT IS NOT INSERTED.

* JUMPERS W17 AND W18 MUST ALSO BE INSERTED AS SHOWN BELOW.

20MA CURRENT LOOP

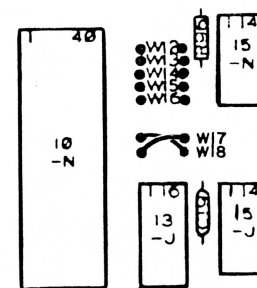

EIA RS232-C

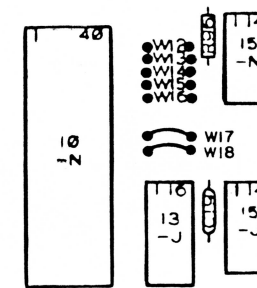

JUMPERS W17 AND W18 MUST NOT TOUCH!

W23 IS INSERTED TO DETERMINE THE BAUD RATE AS SHOWN BELOW: (9600 SHOWN)

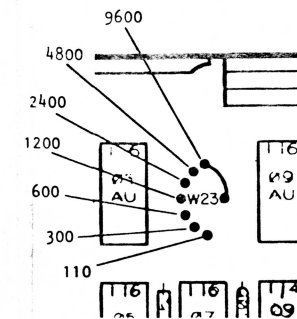

W22 IS NEVER INSERTED.

THE FOLLOWING JUMPERS ARE ALWAYS INSERTED:

- W5
- W19
- W20
- W21
- W24

CPU/MEMORY LOADS

VOLTAGE	DESCRIPTION	CURRENT DRAW
+5V	SYSTEM WITHOUT BATTERY BACKUP	8.0A
+5V	SYSTEM WITH BATTERY BACKUP	7.5A
+5V MEM		0.5A
+12V MEM		0.7A
+15V		0.04A

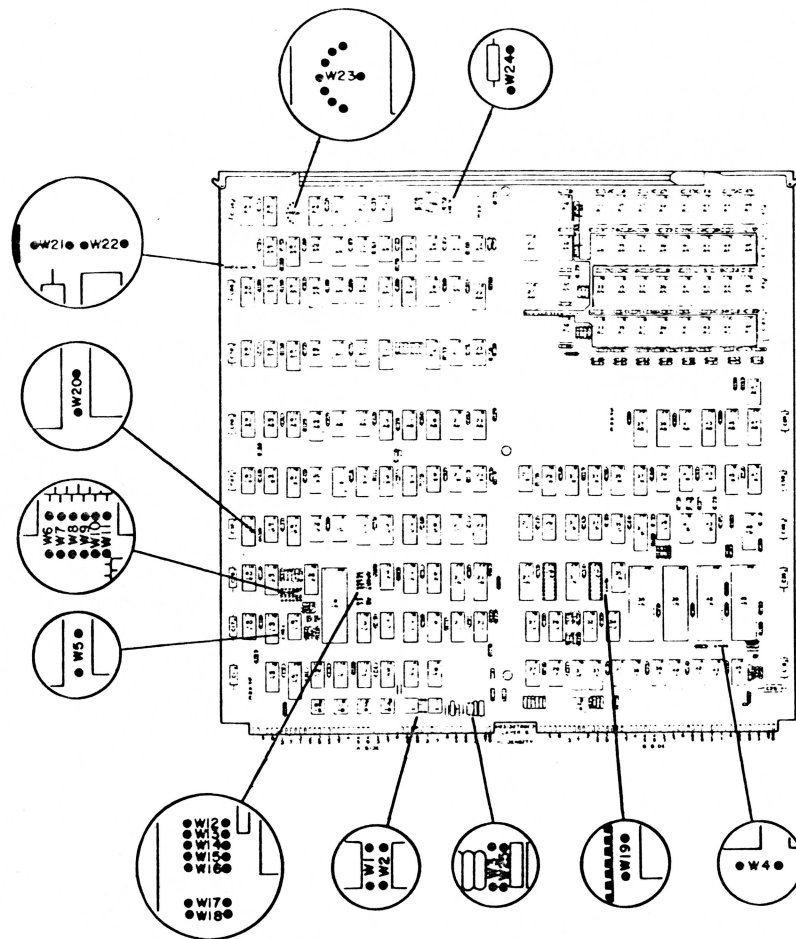

STOP BIT JUMPERS

NUMBER OF STOP BITS	W15 JUMPER POSITION
1	IN
2	OUT

PARITY JUMPERS

TYPE OF PARITY	JUMPER POSITION	
	W12	W16
EVEN	OUT	IN
ODD	IN	IN
NONE	OUT	OUT

CHARACTER LENGTH JUMPERS

CHARACTER LENGTH	JUMPER POSITION	
	W13	W14
5 BITS	IN	IN
6 BITS	OUT	IN
7 BITS	IN	OUT
8 BITS	OUT	OUT

THIS DRAWING AND SPECIFICATIONS, HEREIN, ARE THE PROPERTY OF DATA GENERAL CORPORATION AND SHALL NOT BE REPRODUCED OR COPIED OR USED IN WHOLE OR IN PART AS THE BASIS FOR MANUFACTURE OR SALE OF ITEMS WITHOUT WRITTEN PERMISSION.

REV	DATE	APP	ENGINEER	DRAWN	CHECKED	APPROVED	FIRST USED ON	CODE IDENT
ECO								34984
APP								
DATE								

TITLE
INSTALLATION DATA SHEET
NOVA 4 5-SLOT

DATA GENERAL CORPORATION WESTBORO, MASSACHUSETTS 01581			
SIZE	CODE	DRAWING NUMBER	REV
C	010	000212	03

TAILORING (CONT)
CPU JUMPERING
NOVA 4/S OR 4/X

BAUD RATE JUMPERS

BAUD RATE	JUMPER POSITION				
	W17	W18	W19	W20	W27
50	IN	IN	OUT	IN	OUT
75	IN	IN	OUT	OUT	OUT
110	OUT	OUT	OUT	OUT	IN
134.5	IN	OUT	IN	IN	OUT
150	OUT	OUT	OUT	IN	OUT
200	IN	OUT	IN	OUT	OUT
300	OUT	OUT	IN	OUT	OUT
600	IN	OUT	OUT	IN	OUT
1200	OUT	IN	OUT	OUT	OUT
1600	OUT	IN	OUT	IN	OUT
2400	OUT	OUT	IN	IN	OUT
4800	OUT	IN	IN	OUT	OUT
9600	OUT	IN	IN	IN	OUT
19200	IN	IN	IN	OUT	OUT

PARITY JUMPERS

TYPE OF PARITY	JUMPER POSITION	
	W22	W21
EVEN	OUT	IN
ODD	IN	IN
NONE	OUT	OUT

CHARACTER LENGTH JUMPERS

CHARACTER LENGTH	JUMPER POSITION	
	W25	W24
5 BITS	IN	IN
6 BITS	OUT	IN
7 BITS	IN	OUT
8 BITS	OUT	OUT

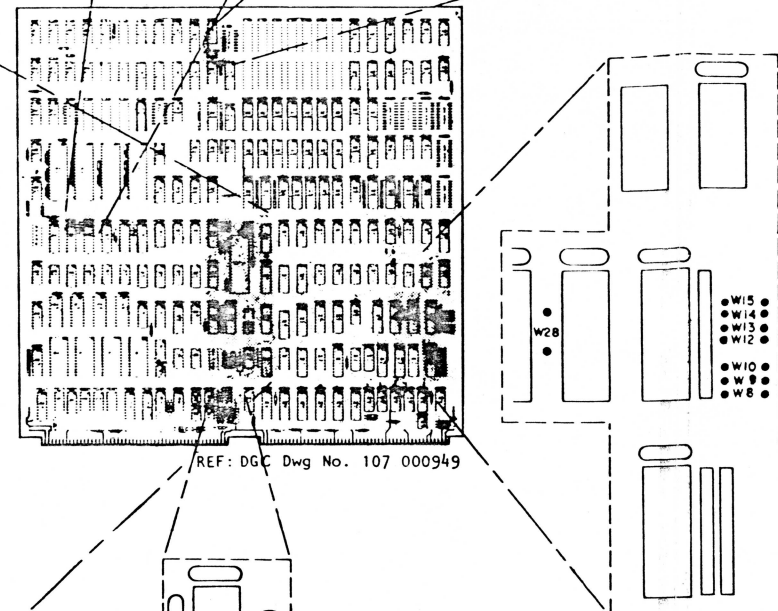
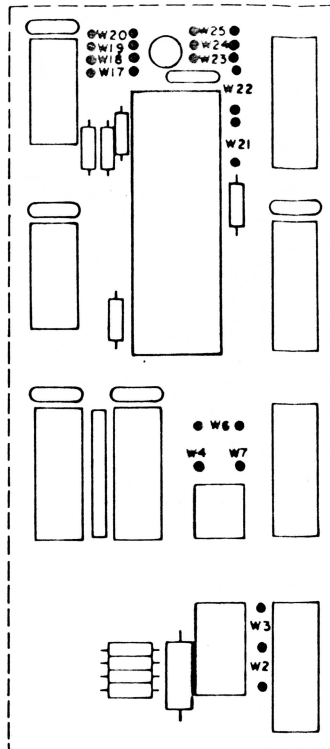

TYPE OF TRANSMISSION JUMPERS

TYPE OF TRANSMISSION	JUMPERS INSERTED
20MA CURRENT LOOP	W4, W7, W2, W1
EIA RS232-C	W6, W3

STOP BIT JUMPERS

NUMBER OF STOP BITS	W23 JUMPER POSITION
1	IN
2	OUT

REAL TIME CLOCK JUMPER

RTC ENABLED	W28
RTC DISABLED	IN
RTC ENABLED	OUT

DEVICE CODE JUMPERS FOR FRONT PANEL AUTOMATIC PROGRAM LOAD
 SELECT THE PROGRAM LOAD DEVICE CODE BY INSTALLING JUMPERS W13, W15, W14, W12, W10, W8 AS FOLLOWS:
 JUMPER IN = 1 JUMPER OUT = 0
 EXAMPLE JUMPERING FOR DEVICE CODE 27 :

W13	W15	W14	W12	W10	W8
OUT	IN	OUT	IN	IN	IN

W9 IS INSERTED IF THE PROGRAM LOAD DEVICE IS A HIGH SPEED DEVICE, OTHERWISE, IT IS REMOVED.
 NOTE: JUMPERS W16 AND W26 ARE ALWAYS INSERTED. JUMPERS W5 AND W11 DO NOT EXIST.

+5V CURRENT DRAW = 17A

013-000840
BRUNING 40-528 27928

THIS DRAWING AND SPECIFICATIONS, HEREIN, ARE THE PROPERTY OF DATA GENERAL CORPORATION AND SHALL NOT BE REPRODUCED OR COPIED OR USED IN WHOLE OR IN PART AS THE BASIS FOR MANUFACTURE OR SALE OF ITEMS WITHOUT WRITTEN PERMISSION.

REV	DATE	APP	ECO	DRAWN	CHECKED	ENGINEER

APPROVED	FIRST USED ON	CODE IDENT
		34984

TITLE
INSTALLATION DATA SHEET
NOVA 4 5-SLOT

DATA GENERAL CORPORATION WESTBORO, MASSACHUSETTS 01581			
SIZE	CODE	DRAWING NUMBER	REV
C	010	000212	03

TAILORING (CONT)

MEMORY JUMPERING NOVA 4/S AND 4/X

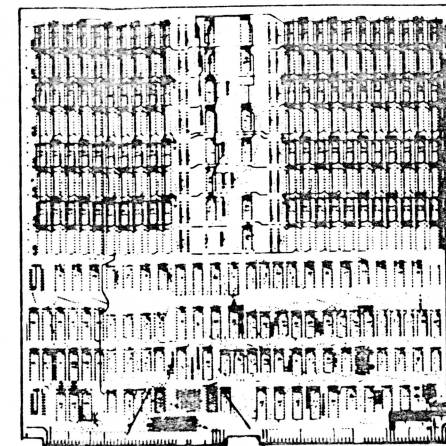

REF: DGC Dwg No. 107 000813

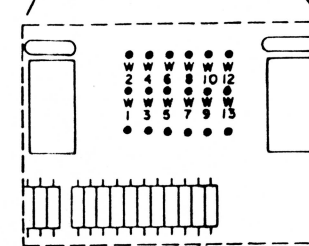

NOVA 4/X MEMORY BOARD SELECT JUMPERS

ADDRESS RANGE	JUMPERS INSERTED*	
	BOARD SIZE	
	256KBYTES	128KBYTES
0377777-	NONE	W7
0300000-		
0277777-		
0200000-		
0177777-		
0100000-		
0077777-		
0000000-		

*NOTE: JUMPERS W1, W3, AND W5 ARE ALWAYS INSERTED.
JUMPERS W2, W4, AND W6 ARE NEVER INSERTED.

NOVA 4/S MEMORY BOARD SELECT JUMPERS

ADDRESS RANGE	JUMPERS INSERTED*	
	BOARD SIZE	
	64 KBYTES	32KBYTES
0077777-	W7 W9	W7 W9 W11
0040000-		
0037777-		
0000000-		

NOTE: JUMPERS W1, W3, AND W5 ARE ALWAYS INSERTED;
JUMPERS W2, W4, AND W6 ARE NEVER INSERTED.

MEMORY LOADS

VOLTAGE	DESCRIPTION	CURRENT DRAW
+5V	SYSTEM WITH BATTERY BACKUP	4.4A
+5V	SYSTEM WITHOUT BATTERY BACKUP	5.6A
+5V MEM		1.2A
+12V MEM	FIRST BOARD IN CHASSIS	2.3A

013-000840
BRUNING 40-526 27928

THIS DRAWING AND SPECIFICATIONS, HEREIN, ARE THE PROPERTY OF DATA GENERAL CORPORATION AND SHALL NOT BE REPRODUCED OR COPIED OR USED IN WHOLE OR IN PART AS THE BASIS FOR MANUFACTURE OR SALE OF ITEMS WITHOUT WRITTEN PERMISSION

REV	DATE	APP	ECO	DRAWN	CHECKED	ENGINEER	APPROVED	FIRST USED ON	CODE IDENT
									34984

TITLE
INSTALLATION DATA SHEET
NOVA 4 5-SLOT

DATA GENERAL CORPORATION WESTBORO, MASSACHUSETTS 01581			
SIZE C	CODE 010	DRAWING NUMBER 000212	REV 03

4 3 2 1

TAILORING (CONT)
BACKPANEL JUMPERING

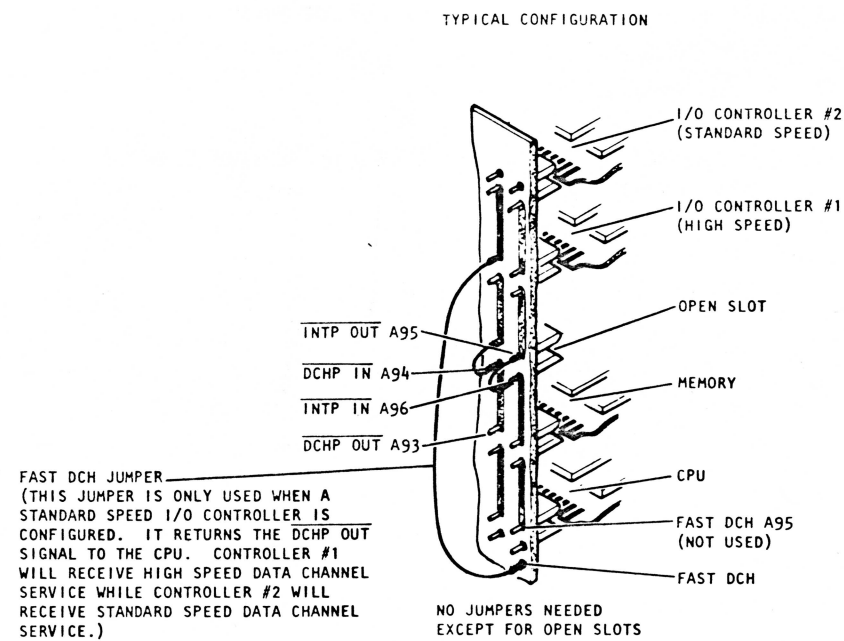

NOTE: WHEN AN I/O CONTROLLER RESIDES OUTSIDE THE CHASSIS, IT MUST BE CONFIGURED AS A STANDARD DATA CHANNEL CONTROLLER.

FOR MORE INFORMATION CONCERNING INTERRUPT AND DATA CHANNEL PRIORITY SCHEMES, REFER TO THE INTERFACE DESIGNER'S REFERENCE, NOVA AND ECLIPSE LINE COMPUTERS, DG NO. 015-000031.

DG-05828

INTERNAL CABLING
BACKPANEL CONNECTORS

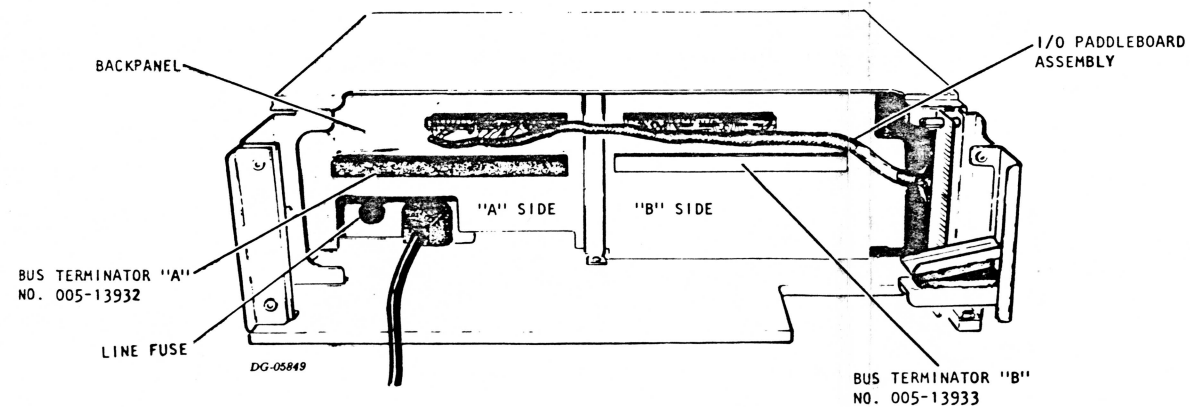
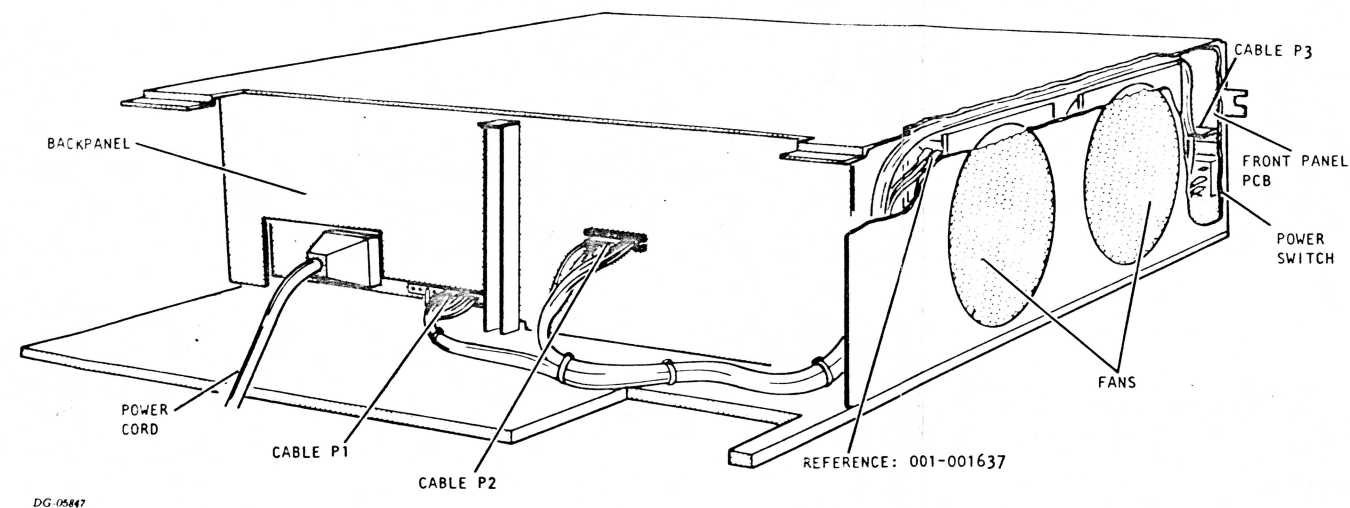

A
013-000840
BRUNING 40-526 27928

THIS DRAWING AND SPECIFICATIONS, HEREIN, ARE THE PROPERTY OF DATA GENERAL CORPORATION AND SHALL NOT BE REPRODUCED OR COPIED OR USED IN WHOLE OR IN PART AS THE BASIS FOR MANUFACTURE OR SALE OF ITEMS WITHOUT WRITTEN PERMISSION

REV	DATE	APP	ECO

DRAWN	APPROVED
CHECKED	FIRST USED ON
ENGINEER	CODE IDENT 34984

TITLE
INSTALLATION DATA SHEET
NOVA 4 5-SLOT

DATA GENERAL CORPORATION			
WESTBORO, MASSACHUSETTS 01581			
SIZE	CODE	DRAWING NUMBER	REV
C	010	000212	03

INTERNAL CABLING (CONT)

PADDLEBOARD MOUNTING

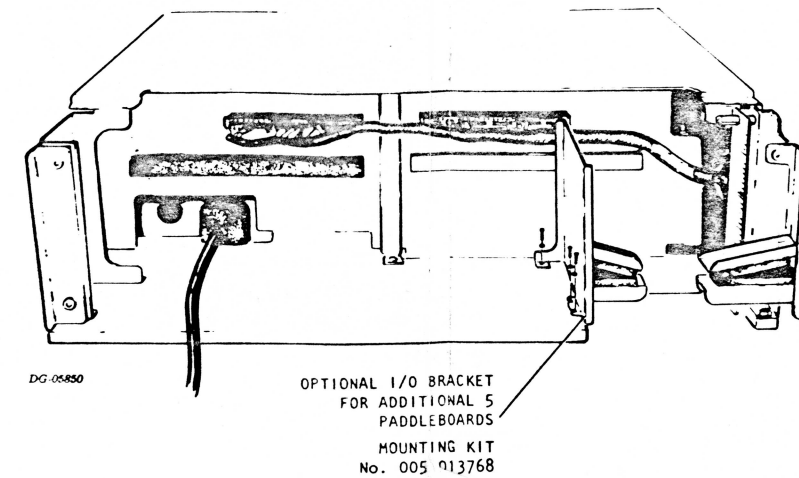
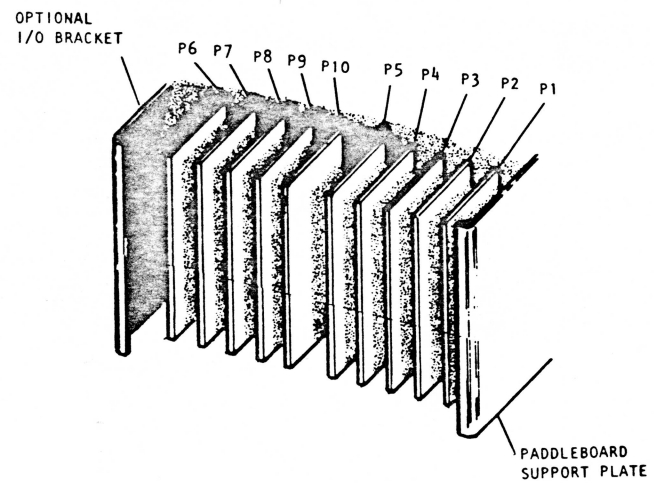

NOVA 4 I/O PADDLEBOARDS

ASSEMBLY No.	TYPE
005 012472	GENERAL PURPOSE I/O
005 012751	EXTERNAL I/O BUS**
005 012765	UNIVERSAL LINE MUX (SYNC) MODEL 4241, 4241A, 4242, 4243***
005 012476	I/O BUS REPEATER MODEL 8315
005 012590	DCU-50 MODELS 4250, 4254
005 012473*	ASYNCHRONOUS INTERFACE MODELS 4007, 4010, 4023, 4075, 4077, 4078
005 012585	MCA MODEL 4206

* THIS PADDLEBOARD MUST BE PLACED IN THE OUTSIDE POSITION: I.e. THE FURTHEST AWAY FROM THE PADDLEBOARD SUPPORT PLATE.

** EXTERNAL I/O BUS MUST BE TERMINATED AT THE END AWAY FROM THE COMPUTER BY TERMINATOR NO. 005-9067, OR EQUIVALENT.

*** REQUIRES TWO PADDLEBOARD LOCATIONS.

POWER SYSTEM LOADING RULES:

- SUPPLY VOLTAGES +5V, +12V, -5V ARE TIGHTLY REGULATED (SEE 001-001615 FOR LIMITS). +15 VOLTS IS NOT LOAD REGULATED; IT'S TYPICAL OUTPUT VOLTAGE IS SHOWN IN THE GRAPH TO THE RIGHT.
- LOADING ON +5V VOLTS MUST BE DIVIDED SO THAT SLOTS 1 AND 2 DRAW LESS THAN 22 AMPERES, SLOTS 3, 4, AND 5 DRAW LESS THAN 22 AMPERES AND THE TOTAL LOAD IS LESS THAN 35 AMPERES.

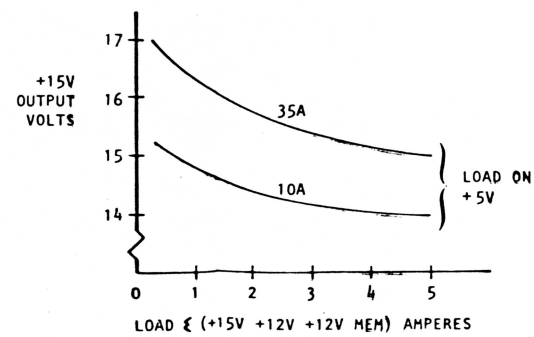

013-000640
BRUNING 40-526 27928

THIS DRAWING AND SPECIFICATIONS, HEREIN, ARE THE PROPERTY OF DATA GENERAL CORPORATION AND SHALL NOT BE REPRODUCED OR COPIED OR USED IN WHOLE OR IN PART AS THE BASIS FOR MANUFACTURE OR SALE OF ITEMS WITHOUT WRITTEN PERMISSION

REV	ECO	APP	DATE

DRAWN	APPROVED
CHECKED	FIRST USED ON
ENGINEER	CODE IDENT 34984

TITLE
INSTALLATION DATA SHEET
NOVA 4 5-SLOT

DATA GENERAL CORPORATION WESTBORO, MASSACHUSETTS 01581			
SIZE	CODE	DRAWING NUMBER	REV
C	010	000212	03

CABINET MOUNTING

INSERTING PC BOARD

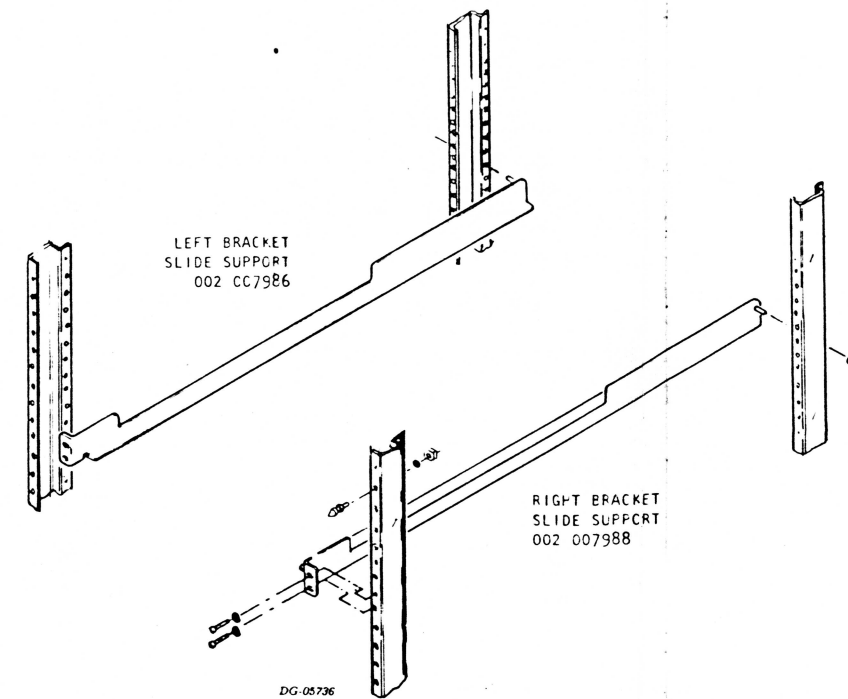
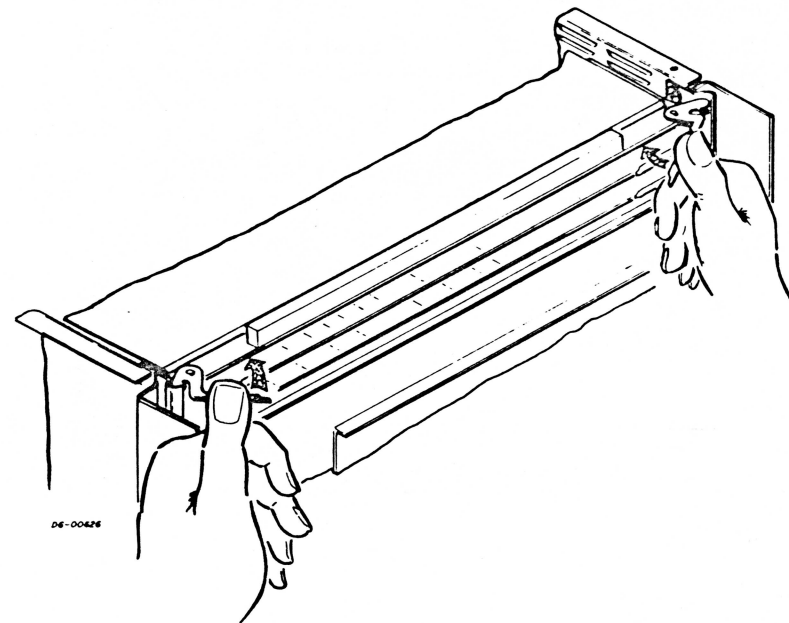

INSERTING POWER SUPPLY PCB

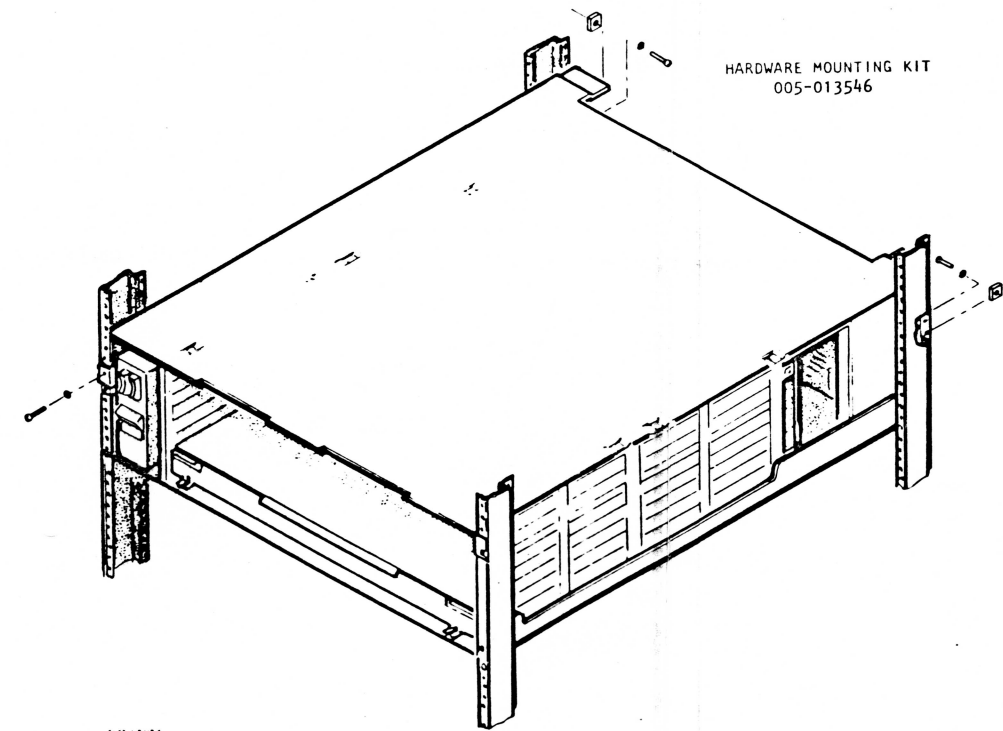
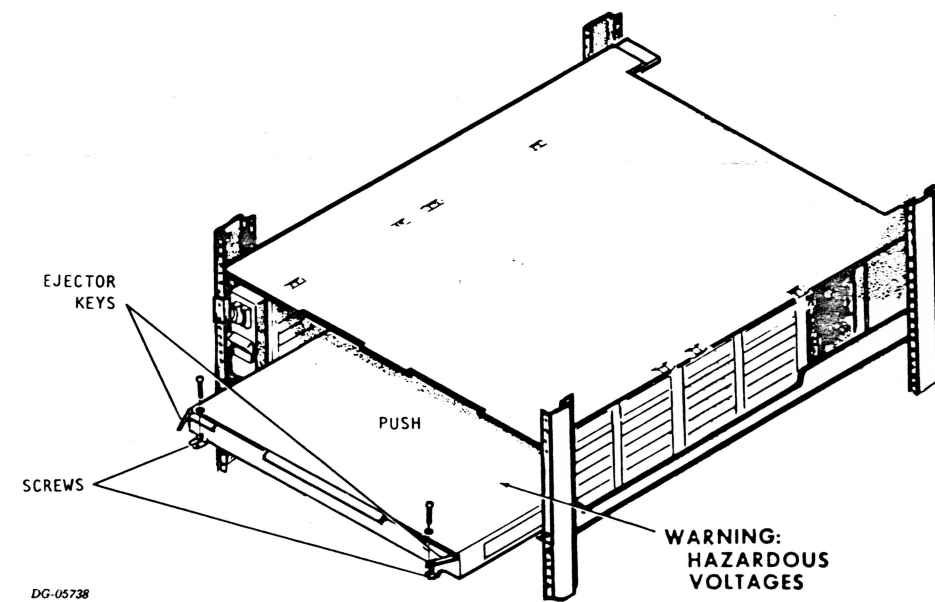

013-000840
BRUNING 40-556 27928

THIS DRAWING AND SPECIFICATIONS HEREIN ARE THE PROPERTY OF DATA GENERAL CORPORATION AND SHALL NOT BE REPRODUCED OR COPIED OR USED IN WHOLE OR IN PART AS THE BASIS FOR MANUFACTURE OR SALE OF ITEMS WITHOUT WRITTEN PERMISSION.

REV	ECO	APP	DATE

DRAWN	APPROVED
CHECKED	FIRST USED ON
ENGINEER	CODE IDENT 34984

TITLE
INSTALLATION DATA SHEET
NOVA 4 5-SLOT

DATA GENERAL CORPORATION WESTBORO, MASSACHUSETTS 01581			
SIZE	CODE	DRAWING NUMBER	REV
C	010	000212	03