

ALL DIMENSIONS AND SPECIFICATIONS HEREIN ARE THE PROPERTY OF DATA GENERAL CORPORATION AND SHALL NOT BE REPRODUCED OR COPIED IN ANY MANNER WITHOUT WRITTEN PERMISSION.

| REVISIONS |             |      |        |      |
|-----------|-------------|------|--------|------|
| REV       | DESCRIPTION | DATE | APP BY | DATE |
|           |             |      |        |      |

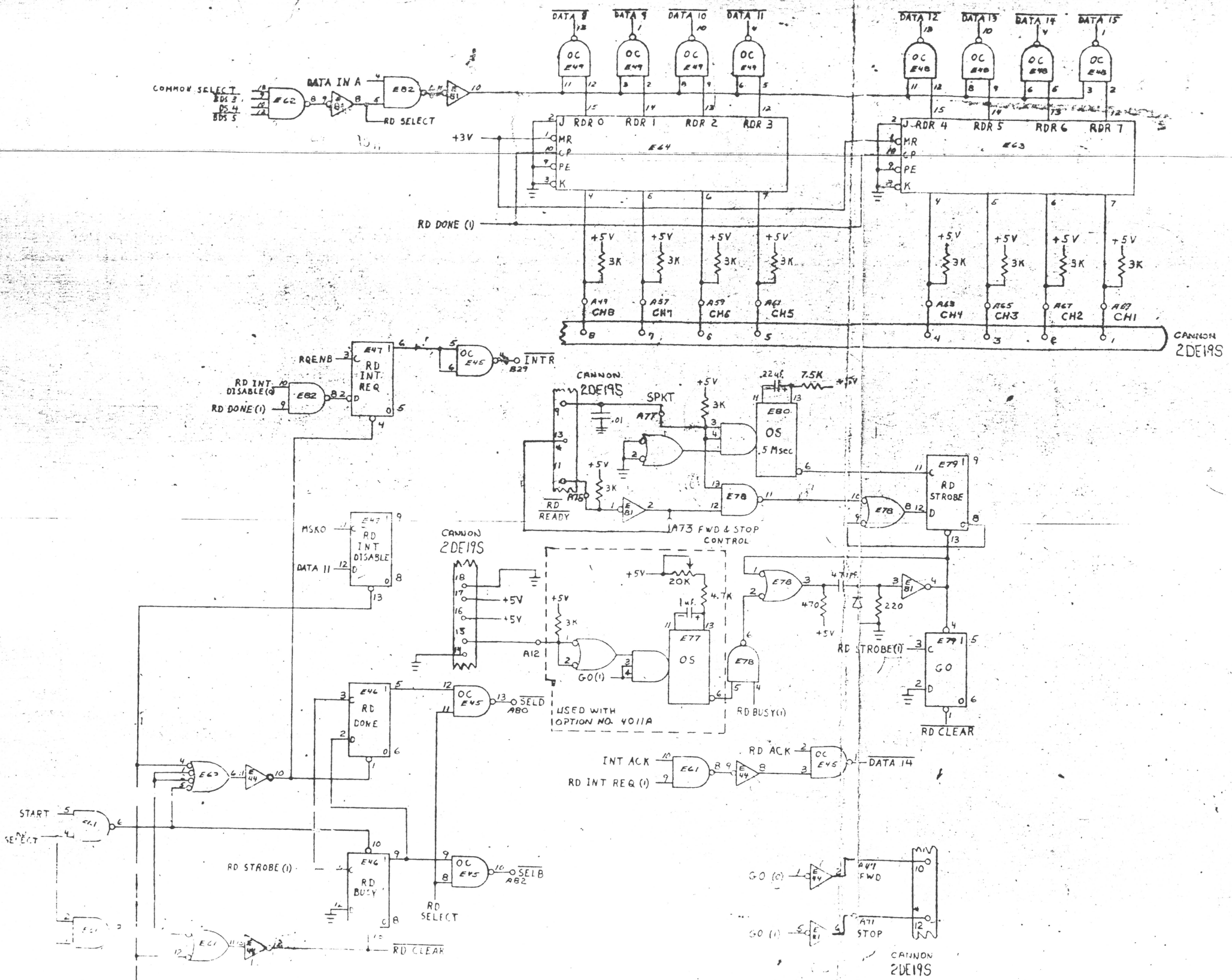

NOTE  
\* USED WITH OPTION NO 4011B

| QTY           |    | DESCRIPTION              |      | ...T NO        |
|---------------|----|--------------------------|------|----------------|
|               |    |                          |      |                |
| DRAWN         |    | DATA GENERAL CORPORATION |      |                |
| CHECKED       |    | TITLE                    |      |                |
| ENGINEER      |    | PAPER TAPE READER        |      |                |
| APPROVED      |    | CONTROL 4011             |      |                |
| FIRST USED ON |    |                          |      |                |
| MATERIAL      |    |                          |      |                |
| FINISH        |    |                          |      |                |
| SHEET         | OF | SIZE                     | CODE | DRAWING NUMBER |
|               |    | D                        | 001  | 000004         |