

**RDOS/DOS Sort/Merge  
and Vertical Format  
Unit Utilities**

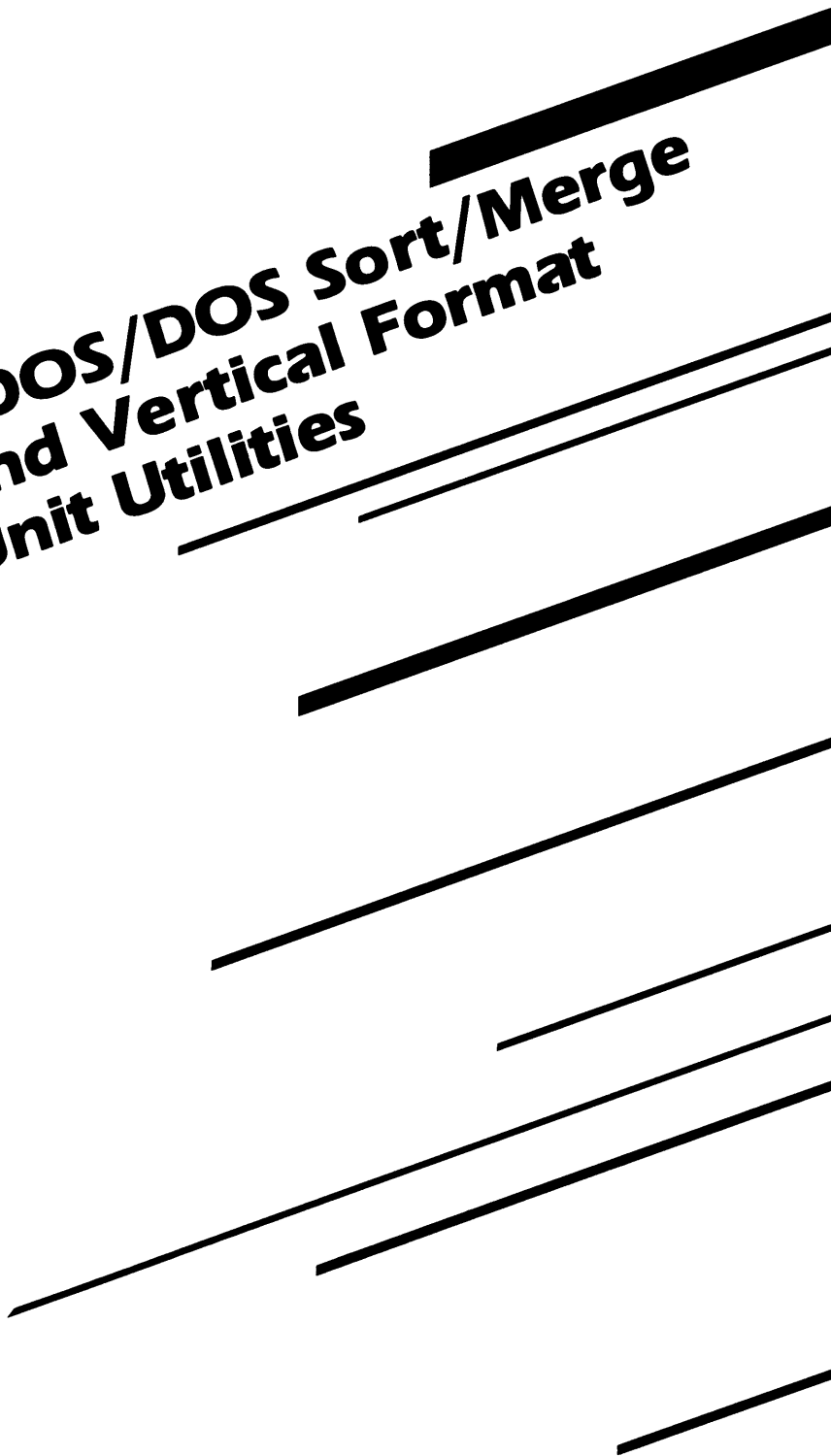

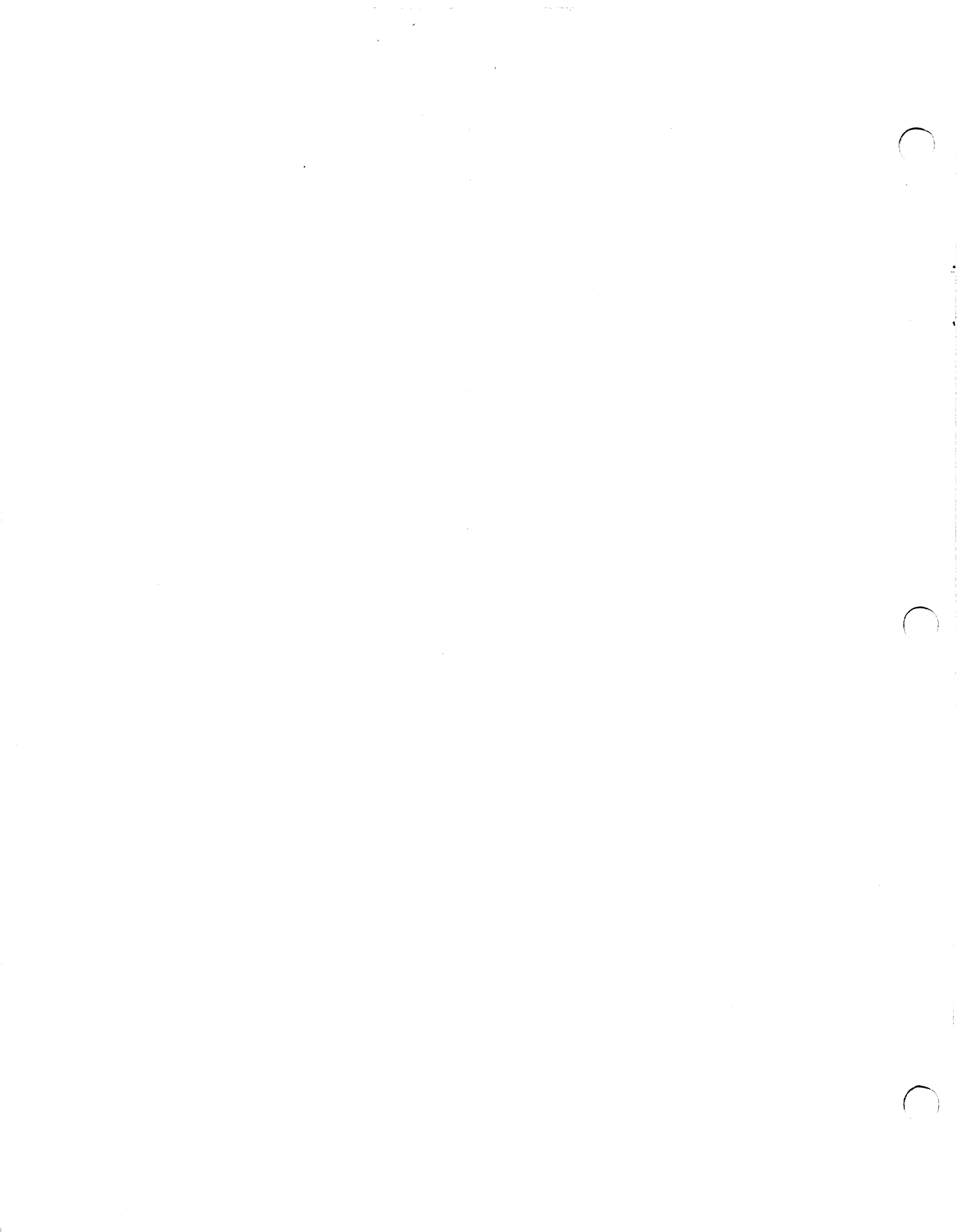

# **RDOS/DOS Sort/Merge and Vertical Format Unit Utilities**

## Notice

Data General Corporation (DGC) has prepared this document for use by DGC personnel, customers, and prospective customers. The information contained herein shall not be reproduced in whole or in part without DGC's prior written approval.

DGC reserves the right to make changes in specifications and other information contained in this document without prior notice, and the reader should in all cases consult DGC to determine whether any such changes have been made.

THE TERMS AND CONDITIONS GOVERNING THE SALE OF DGC HARDWARE PRODUCTS AND THE LICENSING OF DGC SOFTWARE CONSIST SOLELY OF THOSE SET FORTH IN THE WRITTEN CONTRACTS BETWEEN DGC AND ITS CUSTOMERS. NO REPRESENTATION OR OTHER AFFIRMATION OF FACT CONTAINED IN THIS DOCUMENT INCLUDING BUT NOT LIMITED TO STATEMENTS REGARDING CAPACITY, RESPONSE-TIME PERFORMANCE, SUITABILITY FOR USE OR PERFORMANCE OF PRODUCTS DESCRIBED HEREIN SHALL BE DEEMED TO BE A WARRANTY BY DGC FOR ANY PURPOSE, OR GIVE RISE TO ANY LIABILITY OF DGC WHATSOEVER.

IN NO EVENT SHALL DGC BE LIABLE FOR ANY INCIDENTAL, INDIRECT, SPECIAL OR CONSEQUENTIAL DAMAGES WHATSOEVER (INCLUDING BUT NOT LIMITED TO LOST PROFITS) ARISING OUT OF OR RELATED TO THIS DOCUMENT OR THE INFORMATION CONTAINED IN IT, EVEN IF DGC HAS BEEN ADVISED, KNEW OR SHOULD HAVE KNOWN OF THE POSSIBILITY OF SUCH DAMAGES.

CEO, DASHER, DATAPREP, ECLIPSE, INFOS, ENTERPRISE, microNOVA, NOVA, PROXI, SUPERNOVA, ECLIPSE MV/4000, ECLIPSE MV/6000, ECLIPSE MV/8000, TRENDVIEW, MANAP, and PRESENT are U.S. registered trademarks of Data General Corporation, and AZ-TEXT, ECLIPSE MV/10000, GW/4000, GDC/1000, REV-UP, SWAT, XODIAC, GENAP, DEFINE, SLATE, microECLIPSE, BusiPEN, BusiGEN, DG/L, and BusiTEXT are U.S. trademarks of Data General Corporation.

Ordering No. 069-400021

© Data General Corporation, 1983

All Rights Reserved

Printed in the United States of America

Rev. 00, June 1983

---

# Preface

This manual describes two utilities. The first is the Sort/Merge utility that is capable of rearranging, deleting, and reformatting records in a disk or tape file. It can also produce sorted address files and merge a number of disk or tape files into a single file. The execution is initiated with the Command Line Interpreter (CLI) or the Batch monitor. The Batch monitor allows you to simulate a CLI session by grouping Batch commands in a file for later processing. Batch accepts job routines from a variety of devices and sends output to specified disk files or devices. For further information, see the *RDOS/DOS Command Line Interpreter* (DGC No. 069-400015).

The second utility, called the Vertical Format Unit (VFU), allows you to create and edit format control files for data channel line printers. Both utilities operate as processing programs under the Real-Time Disk Operating System (RDOS). Sort/Merge also operates under the Disk Operating System (DOS).

## Reading Path

To use this manual properly, you will need some experience with the CLI. Review the *RDOS/DOS Command Line Interpreter* (DGC No. 069-400015) if you are not familiar with the CLI. You should also be familiar with a text editor. See the *RDOS/DOS Text Editor* (DGC No. 069-400016) or the *RDOS/DOS Superedit Text Editor* (DGC No. 069-400017).

## Manual Organization

We have organized this manual as follows:

Part I contains Chapters 1 through 3 and deals with the Sort/Merge Utility.

Chapter 1, "Introduction to Sort/Merge," introduces you to and gives you a general description of the functions of Sort/Merge. It also describes system preparations.

Chapter 2, "Operating Procedures," explains the command line format and command switches. It also explains the operations needed to complete a Sort/Merge procedure. These operations include specification of input, output, and control limits; keyfields; collating sequences; and work file usage.

Chapter 3, "Operating Cycles," describes the operating cycles of both sort and merge operations.

Part II contains chapter 4 and describes the Direct Access Vertical Format Unit (DAVFU).

Chapter 4, "Introduction to Direct Access Vertical Format Unit," introduces DAVFU. It explains in detail the operating procedures for creating, editing, loading, and displaying a .VF file. It also covers channels and indexing to channels.

Appendix A, "Sort/Merge Error Messages," lists and defines Sort/Merge error messages.

Appendix B, "Timing and Storage Considerations," describes timing and storage considerations for the Sort/Merge Utility.

The following manuals are part of a series of books that document RDOS and DOS.

*Introduction to RDOS* (DGC No. 069-400011) describes the fundamentals of using RDOS and summarizes the features, utilities, and capabilities of the operating system.

*Guide to RDOS Documentation* (DGC No. 069-400012) describes all of the books that comprise the revised documentation set for RDOS and DOS, and lists the previous books that each replaces.

*How to Load and Generate RDOS* (DGC No. 069-400013) explains how to load, generate, and maintain RDOS. Instructions are provided for preparing hardware, program loading, initializing disks, installing the bootstrap root and starter system, tailoring, and system backup, among others.

*How to Generate Your DOS System* (DGC No. 093-000222-01) explains how to generate and maintain DOS. Instructions are provided for preparing hardware, initializing disks, installing the bootstrap root and starter system, tailoring, system backup, and optimization, among others.

*RDOS/DOS Command Line Interpreter* (DGC No. 069-400015) discusses the user interface with the operating system. It covers the Command Line Interpreter (CLI) features and command mechanisms, as well as instructions on how to

use CLI commands. It also presents features and operation of the Batch monitor, a CLI utility.

*RDOS/DOS Text Editor* (DGC No. 069-400016) documents how to load, use, and operate the single-user Text Editor (Edit) or Multi-user Text Editor (Medit) to create and edit text files.

*RDOS/DOS Superedit Text Editor* (DGC No. 069-400017) introduces the commands and concepts of the Superedit Text Editor (Speed), which offers many powerful features for editing text.

*RDOS System Reference* (DGC No. 093-400027) describes RDOS system features, system calls, and user device driver implementation for assembly language and high-level language programming.

*DOS Reference Manual* (DGC No. 093-000201-03) discusses all features of DOS including system control, memory management, and system calls for system programmers.

*RDOS/DOS User's Handbook* (DGC No. 093-000105-04) summarizes the commands, calls, and error messages of RDOS and DOS, the Command Line Interpreter (CLI), the text editors (Edit, Medit, and Speed), the Batch monitor, and utility programs.

*RDOS/DOS Assembly Language and Program Utilities* (DGC No. 069-400019) details the Extended Assembler (ASM), Macroassembler (MAC), Extended Relocatable Loader (RLDR and OVLDR), and Library File Editor (LFE) utilities that aid in programming.

*RDOS/DOS Debugging Utilities* (DGC No. 069-400020) describes five utilities that assist you in editing, debugging, and patching programs—the Symbolic Editor (SEdit), Symbolic Debugger (DEBUG), Disk Editor (DSKED), and Patch (ENPAT and PATCH).

*RDOS/DOS Backup Utilities* (DGC No. 069-400022) presents the features and operation of the utilities that perform disk and tape backup. These are BURST/TBURST, DBURST/MBURST/RBURST, DDUMP/DLOAD, FDUMP/FLOAD, and OWNER.

## Typesetting Conventions

We use the following conventions for command formats in this manual:

COMMAND *required* [*optional*] . . . .

Where	Means
COMMAND	Enter the command or its accepted abbreviation as shown. Uppercase letters indicate the command mnemonic.
<i>required</i>	Enter an argument such as a filename. Lowercase italic letters indicate this argument.  Required arguments also appear as:  <i>required<sub>1</sub>   required<sub>2</sub></i>  In this case, you may choose between the arguments. Do not type the vertical bar; it merely separates the choices.
[ <i>optional</i> ]	Brackets mean that you have the option of entering the argument indicated in lowercase italic letters. Command switches also appear in this format. Do not include the brackets in your code; they only set off the choices.
...	Repeat the preceding entry or entries. The explanation indicates exactly what to repeat.
.	Where this symbol appears, the process has continued without incident and you may now take the next action described.

In examples of dialogue, we use:

THIS TYPEFACE TO SHOW YOUR ENTRY

and

THIS TYPEFACE TO SHOW SYSTEM RESPONSES.

Additionally, we use certain symbols in special ways:

<b>Symbol</b>	<b>Means</b>
<CR>	Carriage Return. Press the CR key on your keyboard. <b>NOTE:</b> If you have a D100, D200, or G300 terminal, you should press the New Line key (NEW LINE) on your keyboard instead.
□	Include a space at this point. We use this to clarify command lines in some cases. Normally, you can see where you should put spaces.
CTRL-	Depress and hold the Control key (CTRL) while you press the character that follows CTRL-
<NL>	New Line. Press the NEW LINE key on your keyboard.
R	RDOS/DOS Command Line Interpreter prompt.

All numbers are decimal unless we indicate otherwise; for example, to indicate octal 35, we use 35<sub>8</sub>.

The keys defined as DEL and RUBOUT perform the same function. Depending on the console you are using, you will find one of these keys on your keyboard. In this manual, we use DEL to represent that function.

The up arrow symbol (↑) is also executed by different keys, depending on your console. You execute it by pressing either SHIFT-N or SHIFT-6. In this manual, we reference SHIFT-6 to execute the up arrow symbol.

We welcome your suggestions for the improvement of this and other Data General publications. To communicate with us, use the postpaid comment form at the end of this manual.

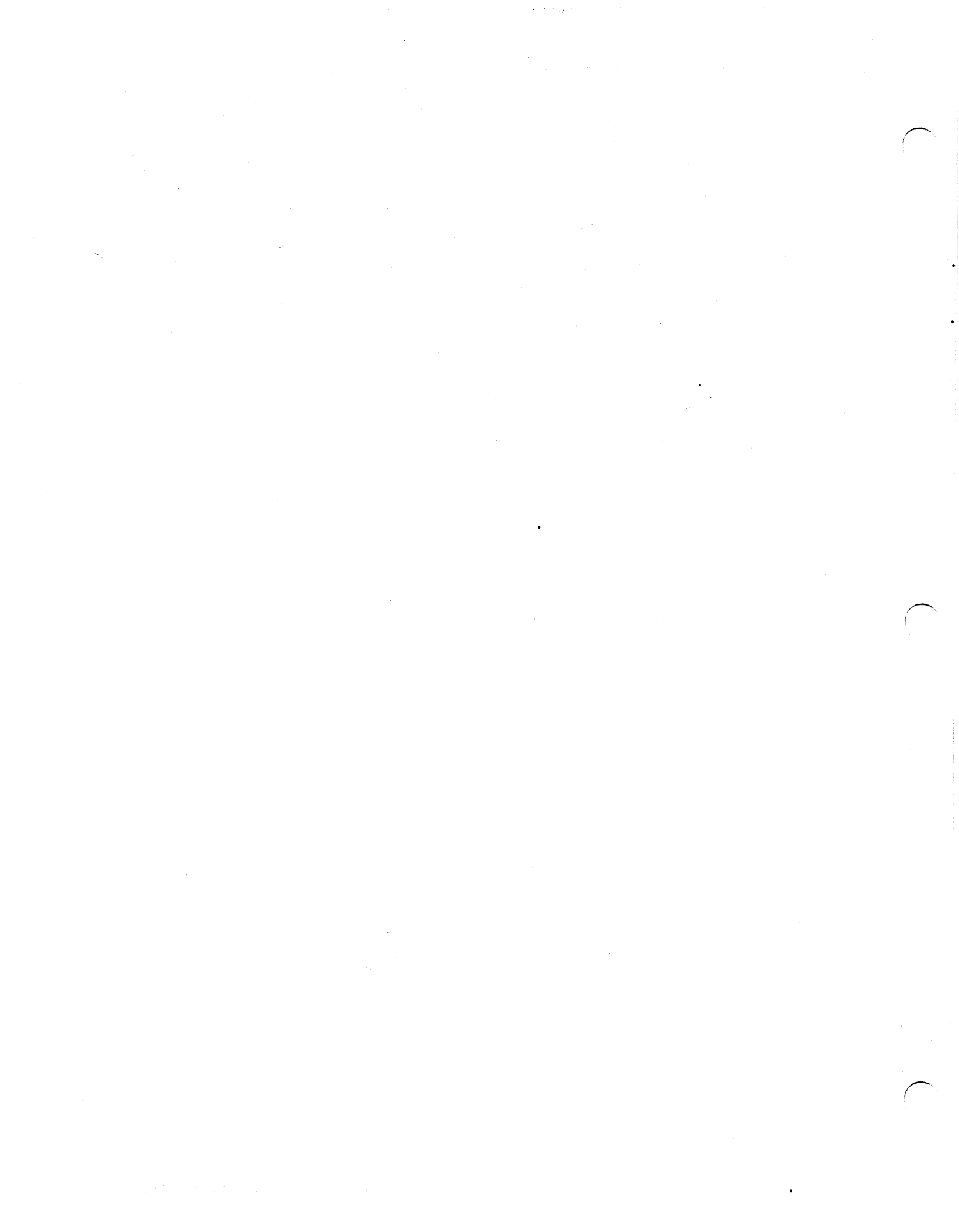



---

# Table of Contents

---

## Preface

Reading Path i  
Manual Organization i  
Typesetting Conventions ii

---

## Part I 1

### Sort/Merge Utility

---

#### Chapter 1

##### Introduction to Sort/Merge

Operation 3  
RDOS Sort/Merge Functions 3  
    Rearranging Records 3  
    Deleting Records 4  
    Reformatting Records 4  
    Producing Address Files 4  
    Merging Files 4  
System Preparation 4

---

#### Chapter 2

##### Operating Procedures

Command Line Format 7  
Collating Sequence 7  
Key Fields 8  
Input/Output Control Field  
    Specifications 8  
Control Limit Specifications 9  
Deleting Records 9  
Work File Usage 9

---

#### Chapter 3

##### Operating Cycles

Sort Operating Cycle 11  
Merge Operating Cycle 12

---

## Part II 13

### Format Utilities

---

#### Chapter 4

##### Introduction to Direct Access Vertical Format Unit

Command Line Format and  
    Description 15  
Creating a Vertical Format File 16  
Displaying a VFU File Setting 17  
Editing a VFU File 18  
Accessing the Printer's Memory 18  
Loading a File Into the Printer's  
    Memory 18  
Indexing to Selected Channels 19  
Indexing Cautions 20

---

## Appendix A 21

### Sort/Merge Error Messages

Error Messages 21

---

## Appendix B 23

### Timing and Storage Considerations

Main Storage Size 23  
Number of Records to be Sorted 23  
Record/Control Field Size 23  
Alternate Collating Sequence 23  
Location of the Files 23

---

## Index 25

### DG Offices

### How to Order Technical Publications

### ISD User Documentation Remarks Form

### Users' Group Membership Form

## **Figures**

- 1.1 Rearranging records 3
- 1.2 Deleting records 4
- 1.3 Reformatting records 4
- 1.4 Producing address files 4
- 1.5 Merging files 4
- 2.1 RDOS SORT/MERGE CLI command  
line format 7
- 2.2 Key field structures 8
- 3.1 Input record format 11
- 3.2 Resulting work record 11
- 4.1 Creating a .VF file 17

## **Tables**

- 2.1 Sort/Merge switches 7
- 3.1 Core loads of work records 11
- 4.1 VFU command switches 16
- 4.2 File setting switches 17
- 4.3 DAVFU control byte codes for skip  
to channel 19
- 4.4 DAVFU control byte codes 20

# Part I

---

## Sort/Merge Utility



## Introduction to Sort/Merge

Sort/Merge is a disk-oriented utility that operates as a processing program under control of the Real-Time Disk Operating System (RDOS) and the Disk Operating System (DOS). The program runs on any Data General ECLIPSE® or NOVA® system, in the background of an unmapped computer or in either partition of a mapped computer. The utility is executed using the Command Line Interpreter (CLI) or Batch monitor. It can also be executed through a user program.

RDOS Sort/Merge performs the following functions:

- Rearranges the records in a disk or tape file,
- Deletes records from a disk or tape file,
- Reformats the records in a disk or tape file,
- Produces sorted address files for a disk file,
- Merges disk or tape files into a single disk or tape file.

Normally, records in output files produced by RDOS Sort/Merge are exact images of records in the input file. A special feature of the utility, however, allows you to select portions of the input records for output. This feature permits you to generate a variety of different output files from a single input file. It can save you time by relieving the need to generate a unique input file for each desired output file.

Another feature allows you to produce an indexed sequential keyed access list by generating an output file that contains pointers to the logical records of the input file and the key fields of those records.

RDOS Sort/Merge has additional options that allow you to specify:

- Collating sequence order and type,
- Major and minor keys,
- Upper and lower bounds.

### Operation

RDOS Sort/Merge accepts as input any sequential, random, or contiguous file containing fixed-length records in unblocked format. Maximum record size is 512 bytes, and the default record size is 80 bytes.

Only one input file can be sorted during a particular execution, but up to six sorted files can be merged at one time.

RDOS Sort/Merge requires the use of temporary workspace. You can control the amount of workspace, thereby increasing the efficiency of a particular execution. Workspace can be located on disk, tape, or both. If you choose not to control workspace, RDOS Sort/Merge does it automatically.

### RDOS Sort/Merge Functions

The following section describes the different functions of the RDOS Sort/Merge program.

#### Rearranging Records

When RDOS Sort/Merge rearranges records, the order of the records in the output file is determined by the collating sequence that you have specified. You can specify ascending or descending ASCII, or a unique collating sequence. Figure 1.1 illustrates how records can be rearranged.

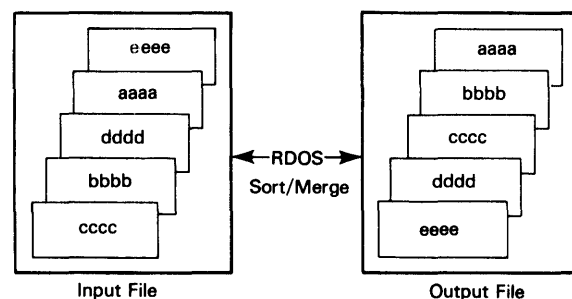

Figure 1.1 Rearranging records

DG-09280

## Deleting Records

You can direct RDOS Sort/Merge to include certain records in the output file. The utility will not include any others. Figure 1.2 shows how RDOS Sort/Merge deletes records.

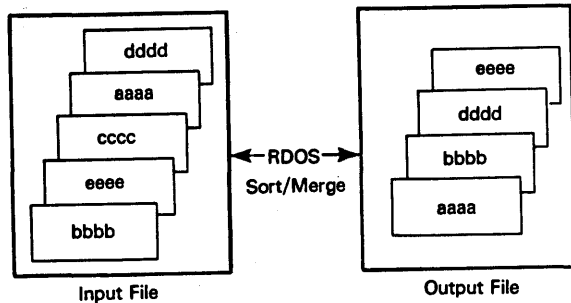

Figure 1.2 Deleting records

DG-09281

## Reformatting Records

Fields in an input record can be rearranged for records in the output file. Figure 1.3 illustrates how the fields are rearranged.

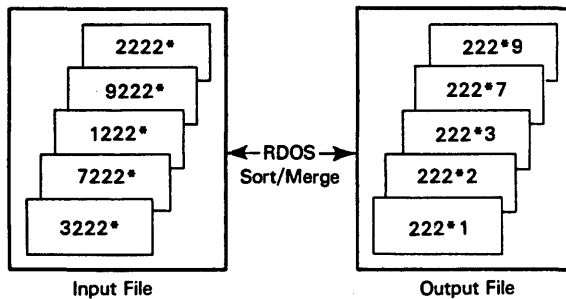

Figure 1.3 Reformatting records

DG-09282

## Producing Address Files

RDOS Sort/Merge can produce an output file in which the records contain the relative record address of the records in the input file. Such an output file is called a *tag* file. Figure 1.4 demonstrates how the RDOS Sort/Merge utility produces address files.

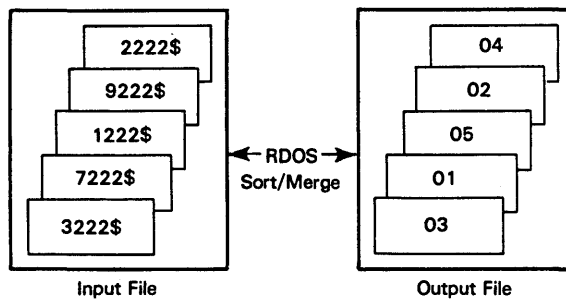

Figure 1.4 Producing address files

DG-09283

## Merging Files

RDOS Sort/Merge can combine up to six previously sorted input files into a single, sorted output file. Figure 1.5 shows how input files are combined.

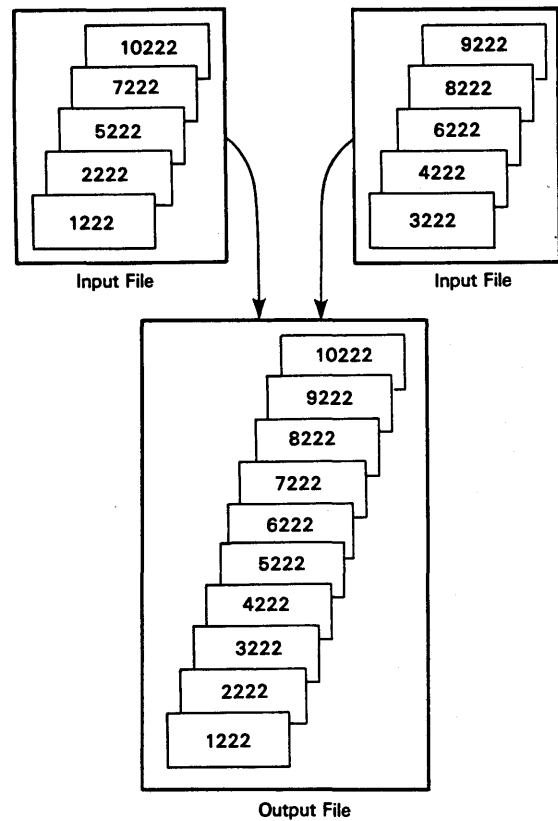

Figure 1.5 Merging files

DG-09284

## System Preparation

Your computer system must be operating under the Data General Real-Time Disk Operating System (RDOS) and have at least a 10-Kword user program partition available to the RDOS Sort/Merge utility. The utility is supplied to licensed users in the form of an RDOS dump file containing relocatable binaries of the utilities mainline program and the overlays.

The RDOS dump file contains the following modules:

```

RDOSSORT.RB
SORTG.RB
SORTL.RB
SORTM.RB
SORTP.RB
SORTT.RB
MERGE.RB
SORTE.RB
    
```

Once you have loaded the dump tape on the disk, a relocatable load must be performed to link these modules together into a save file and an overlay file.

The load command is:

```
RLDR RDOSSORT [SORTG  SORTE, SORTP  SORTM,↑  
SORTL, MERGE SORTT] loadmap/L
```

The current system library (SYS.LB) must be used, because RDOS Sort/Merge is a multitasking program, and the multitasking modules on mapped and unmapped RDOS systems are different.

RDOSSORT *must* then be patched using the patch file (refer to the RDOS monthly newsletter for further information).

**NOTE:** Intermediate storage (also called work areas) is required for every sorting job. The storage can be assigned on the following devices:

- cassette tape units
- magnetic tape units
- fixed-head disks
- moving-head disks

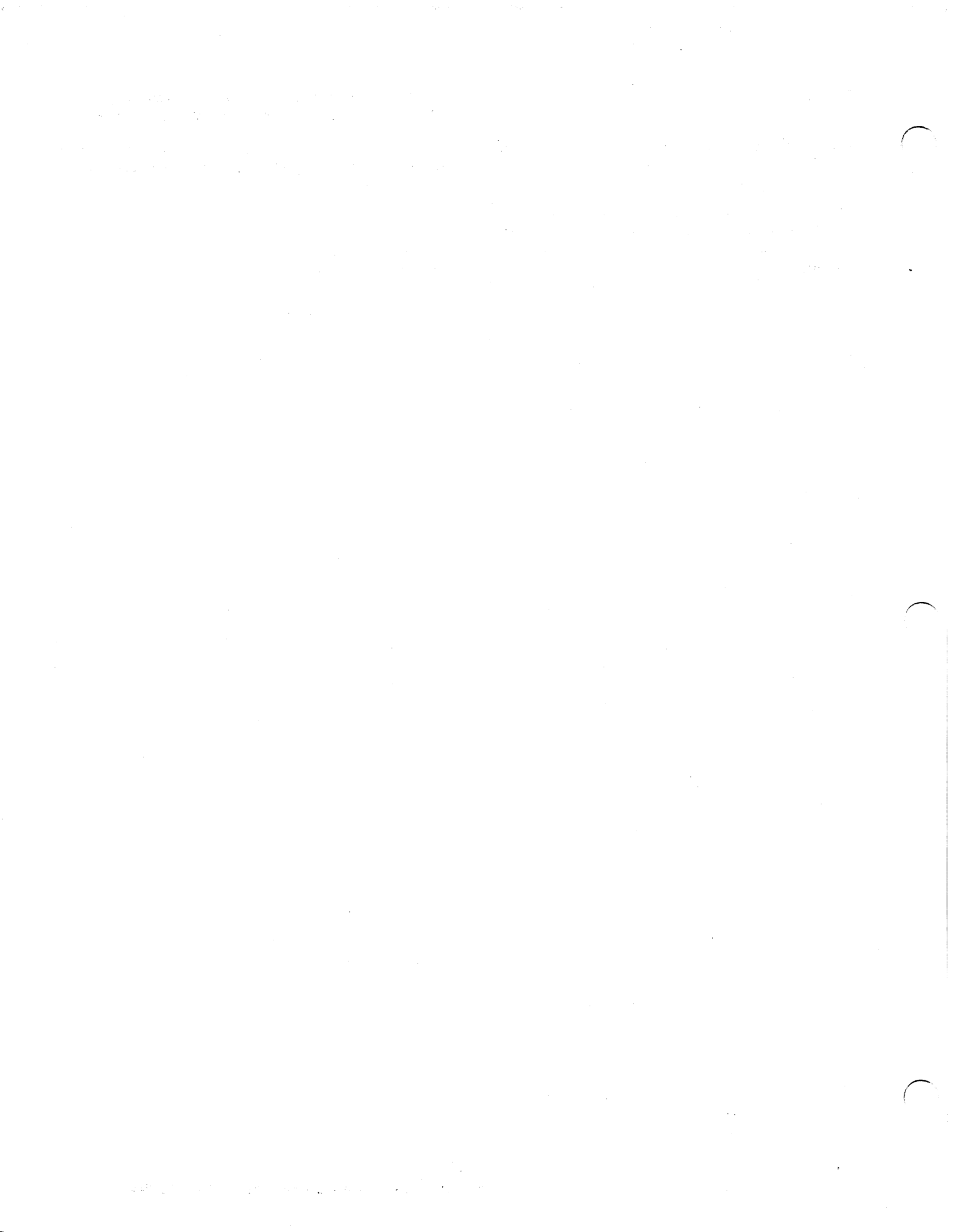



## Operating Procedures

### Command Line Format

You can execute RDOS Sort/Merge with a CLI command line entered through the operator console; with a BATCH job file; or with a user program. The CLI command line format is shown in Figure 2.1. Table 2.1 lists all of the switches available for use with the RDOS Sort/Merge utility.

The BATCH command line is similar to the CLI command line in format. In the BATCH command line, however, an exclamation point appears before RDOSSORT, and the pound sign appears as the first character in continuation lines.

```
RDOSSORT(/D)(/N)(/M)↑
  INPUT FILENAME(/D)↑
  (INPUT FILE 2) (INPUT FILE 3)↑
  (INPUT FILE 4) (INPUT FILE 5)↑
  (INPUT FILE 6)↑
  (OUTPUT FILENAME/O)↑
  KEY SPECIFIER 1↑
  (KEY SPECIFIER 2)↑
  (KEY SPECIFIER 3) (KEY SPECIFIER 4)↑
  (KEY SPECIFIER 5) (KEY SPECIFIER 6)↑
  (KEY SPECIFIER 7) (KEY SPECIFIER 8)↑
  (OUTPUT FIELD 1) (OUTPUT FIELD 2)↑
  (OUTPUT FIELD 3) (OUTPUT FIELD 4)↑
  (OUTPUT FIELD 5) (OUTPUT FIELD 6)↑
  (OUTPUT FIELD 7) (OUTPUT FIELD 8)↑
  (WORK FILE 1/W) (WORK FILE 2/W)↑
  (WORK FILE 3/W) (WORK FILE 4/W)↑
  (SORTED KEY FILENAME/K)↑
  (LISTING FILENAME/L)↑
  (SEQUENCE FILENAME/S)↑
  (RECORD SIZE/R)↑
  (LOWER LIMIT FILENAME/B)↑
  (UPPER LIMIT FILENAME/U)
```

NOTE: Information contained in ( ) is optional. Refer to Table 2.1 for an explanation of switches.

Figure 2.1 RDOS SORT/MERGE CLI command line format

Switch	Action
--------	--------

#### Global Switches:

/D	Arranges key fields in descending ASCII collating sequence.
/M	Requests merge operation.
/N	Suppresses the listing of statistics.

#### Local Switches:

/B	Names file containing lower field limit.
/D	Deletes input file after sort is completed. This switch is overridden if no output file is specified.
/K	Names file of sorted keys.
/L	Lists filename for sorting statistics. The listing is output to the console output device (\$TTO or \$TTO1) by default.
/O	Names file of sorted data which is the output file.
/S	Specifies filename for non-ASCII collating sequence.
/R	Gives the record size in decimal.
/U	Names file containing upper field limit.
/W	Specifies work or temporary files. Up to six files can be specified.

Table 2.1 Sort/Merge switches

### Collating Sequence

RDOS Sort/Merge uses ascending or descending ASCII collating sequences, or you can create your own collating sequence. Data in key fields is compared, and the sequence of the data is determined according to the specific collating sequence. The default collating sequence is ascending ASCII. In this sequence the significant byte is the lowest numerical byte. You can make the highest numerical byte the significant byte by using the global switch /D. In straight numerical comparison, characters such as plus (+), minus (-), and exclamation point (!) have higher priority than the alphabetic characters.

You can use a filename followed by the local switch /S to indicate that a user-supplied collating sequence should be used. The file must contain the characters of the collating sequence in order of decreasing priority, and be terminated by a null character (CTRL-Z). This file need only contain the characters with which you are concerned, because all characters not specified are automatically given a lower priority.

Suppose you want to collate a file so that the following characters are in order of descending priorities: alphabetic characters, numeric characters, a space or a dollar sign, and all remaining characters. The following command sequence creates a file named COLLAT, and specifies the collating sequence that we have described.

```
XFER/A $TTI COLLAT <CR>
```

```
ABC...XYZ 0123456789 $ $
```

Terminate the command sequence by typing CTRL-Z, which appears on the screen as a second \$. The file COLLAT can now be used within a sort or merge command line to specify a particular collating sequence. The command line

```
RDOSSORT FILEIN FILEOUT/O COLLAT/S
```

takes the records from the input file (FILEIN) and places them in the following order in the output file (FILEOUT):

```
AA
A1
A$
BA
B$
CA
CC
```

## Key Fields

You can determine the sequence of records in an output file by analyzing the characters that make up the *control word* for a record. RDOS Sort/Merge compares the data in the control word of each record in the input file to determine the sequence of records in the output file.

The control word can be divided into as many as eight *key fields*. The first key field specified has the highest priority and is called the major key field. The remaining fields are minor key fields, and their priorities are determined by the order in which they are specified. Minor key fields are compared only when the comparison of the preceding key field results in an equal condition.

Each key field can be contiguous to, separated from, or overlapping other key fields. Figure 2.2 shows the different ways that a key field can be structured. A key field can occur anywhere in a data record, but a given key field must

be located in the same relative position in each record of the input file.

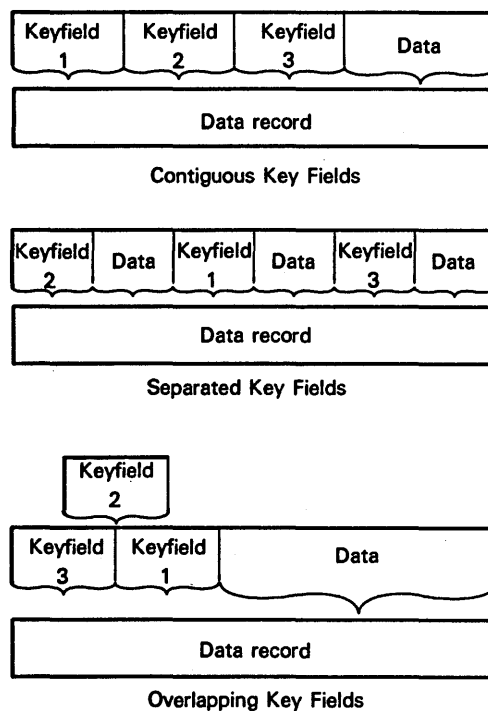

Figure 2.2 Key field structures

ID-00521

## Input/Output Control Field Specifications

Key field specifiers 1 through 8 govern the operation of the RDOS Sort/Merge utility. At least one of these key specifiers must be present for any sort or merge operation. The other seven are optional.

The format of a key field specifier is:

*<starting byte number>.<field length>*

For example, the following key field specifiers—6.10, 18.4, and 103.1—indicate that there is a 10-byte key in positions 6 through 15, a 4-byte key in positions 18 through 21, and a single-byte key at position 103.

Output field specifiers 1 through 8 control the format of the records in the output file (if one is specified). All eight output field specifiers are optional.

When output field specifiers are not used, RDOS Sort/Merge defaults and outputs the complete input record to the output file. The format of an output field specifier is:

*<starting byte number>.<field length>*

For example, the following output field specifiers—1:30 and 50:64—indicate that the output record will be 94 bytes in length, made up of a 30-byte field from positions 1 through 30 of the input record and a 64-byte field from positions 50 through 113 of the input record.

When specifying either key field specifiers or output field specifiers, you must meet the following conditions.

1. The starting byte number must be less than or equal to the size of a record.
2. The field length must be in the range of 1 to 64.
3. The starting byte number plus the field length must not be more than the record size plus 1.
4. There must be no fewer than one and no more than eight key field specifiers.

A maximum number of eight output field specifiers can be used. If output field specifiers are not present, the complete input record is output. In addition, the key field specifiers and output fields can be separated, contiguous, or overlapping.

## Control Limit Specifications

To select certain records from an input file you must specify upper and/or lower limits for the major key field. You can specify the upper and lower limits in the command line by inserting the name of the files in which the limits are contained, followed by the appropriate local switch. These files must be as long as the major key field specified. The upper and lower limit file names specified in the command line can be the same if you want to extract only those records that match the limit file contents exactly. Limit files can be produced under program control or from the operator console.

## Deleting Records

You can mark records to be deleted from a file by setting the first word of the record to zero. The maintenance program that wants to delete records only needs to mark them for deletion; the next operation of the RDOS Sort/Merge utility on the file removes the inactive record.

## Work File Usage

During a sort operation, up to six work files can be used by the RDOS Sort/Merge utility. These files are created in the disk partition in which the utility is operating and are named SORTW1.TP, SORTW2.TP, . . . , SORTW6.TP.

You can use other disks in the system by specifying alternative work files. These files must be specified in the order of their level of activity. Because the level of activity is not uniform, you must consider work file activity when specifying alternative work files. The level of activity is:

Work File 1  
Work File 4  
Work File 2  
Work File 5  
Work File 3  
Work File 6

For example, using three disks, you might specify work files as:

```
DP0:O/W WORK2/W WORK3/W D21:O/W <CR>
```

If the system contains only a dual-disk unit, you should specify alternative work files so that:

1. The first three work files are not on the same disk unit as the input file.
2. The last three work files are on the same disk unit as the input file.

When the system contains only a dual-disk unit, you should specify alternative work files as follows (assuming that DP0 is the current partition):

```
INPUT DP1:W1/W DP1:W2/W DP1:W3/W WORK4/W #  
WORK5/W WORK6/W <CR>
```

**Note:** Magnetic tape cannot be used for work files.



## Operating Cycles

### Sort Operating Cycle

This section lists and describes the steps taken by RDOS Sort/Merge when working with data files in sort mode.

1. RDOS Sort/Merge reads a data record from the input file. This input file must be disk resident if you desire a sorted output file.
2. RDOS Sort/Merge checks the first word of the data record for a nonzero value. When it finds a zero value, RDOS Sort/Merge assumes the record is not active in the data file and bypasses it, going to step 1 again to read another record.
3. RDOS Sort/Merge checks the key field against upper and lower limit bounds (if they have been specified) to see whether the record is to be included in the sort operation.
4. If the record is to be sorted, the utility builds a work record in which the first word specifies the relative record number within the input data file. The remainder of the work record is formatted according to key field specifications. RDOS Sort/Merge extracts the key fields from the input file record and translates them, using appropriate collating sequence. The format of the work record is important because it controls the order of sorting operations.

For example, with the input record format shown in Figure 3.1 assume the key field specifiers are as follows:

The contents of positions 76 through 80 in the input record are the primary key field.

The contents of positions 6 through 10 in the input record are the secondary key field.

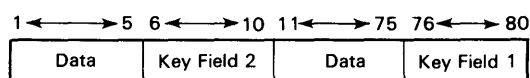

Figure 3.1 Input record format

DG-09285

The work record built is shown in Figure 3.2

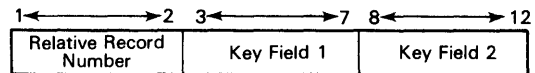

Figure 3.2 Resulting work record

DG-09286

5. The RDOS Sort/Merge utility builds these work records in main memory until it is filled. The utility then sorts these records in memory and writes them out to a work file. The sort operation is in ascending or descending order, in the collating sequence that you have defined. These core loads of work records are written to one of three work files as shown in Table 3.1.

Work File 1	Work File 2	Work File 3
Core load #1	Core load #2	Core load #3
Core load #4	Core load #5	Core load #6
Core load #7	Core load #8	Core load #9
⋮	⋮	⋮

Table 3.1 Core loads of work records

6. RDOS Sort/Merge then merges these work files to produce a single work file of work records in sorted order. The utility builds this single work file by gradually reducing the number of core loads present in the work files. It merges core loads 1, 2, and 3 and stores the output in work file 4. It then merges core loads 4, 5, and 6 and stores the output in work file 5. This continues until the contents of work files 1, 2, and 3 are merged and transferred to work files 4, 5, and 6. Work files 1, 2, and 3 are deleted and the above operation is again performed, with work files 1, 2, and 3 receiving the merged output. This series of operations continues until a single work file is produced.
7. The utility now produces a sorted output file and a sorted tag file.
  - a. To produce a sorted output file, RDOS Sort/Merge reads records from the input file in the order specified by the sorted work file. The record is either completely

written out to the output file or selected parts of the input record (output control field specifiers) are written out sequentially to the output file.

- b. RDOS Sort/Merge retains the sorted work file for the user. This tag file is in the same format as the work file specified in step 5 above.

## Merge Operating Cycle

This section lists and describes the steps taken by RDOS Sort/Merge when working with data files in merge mode.

1. The RDOS Sort/Merge utility reads a data record from each of the merge input files. These input files can be either disk or tape files.
2. The utility extracts the key fields from each record and translates them, using the appropriate collating sequence. It then compares these record key fields to find the lowest order key field.
3. Once the lowest order key field is found, this record is output to the merge output file in total, or the specified output key fields are extracted from the input record and are output to the merge output file.
4. RDOS Sort/Merge reads a data record from the input file to replace the record just written to the merge output file, and then the utility returns to step 2. This loop continues until all input records have been read and written to the merge output file.

**Format Utilities**





## Introduction to Direct Access Vertical Format Unit

The Vertical Format Utility (VFU) allows you to create and edit format control files for data channel line printers which have the Direct Access Vertical Format Unit option installed. These resulting files may then be loaded into the printer's memory, which sets up a specific format for that printer. Three settings are available for the printer forms in each command line: tab stops, form length (in lines), and multiple line-number/channel-number pairs.

The VFU performs the following functions:

- Creates files (always appending the .VF extension to the specified filename).
- Displays page format settings specified in .VF files.
- Edits existing .VF files.
- Loads an existing .VF file into the printer's memory.

The VFU enables and disables access to the printer's memory through user programs. While the utility is running, it disables spooling. (The spooling mechanism diverts output for a slow output device to a temporary disk file.) Upon completion, VFU restores the prior state of spooling (enabled or disabled). The page format of the printer can be changed by loading a new .VF file. The printer returns to the default format if power to the printer is cycled (turned off and then on again).

### Command Line Format and Description

To access the Direct Access Vertical Format Unit (DAVFU), you must execute the VFU command, followed by a global switch. Switches inform the utility which function you want to use. All switches, except the global switches /A and /D, must be followed by a new or existing VFU filename. The /A and /D global switches enable and disable access to DAVFU memory commands, and must be followed by a line printer filename.

The access switches must be used alone in a command line. The create, edit, load, and display switches, however, can be combined in a single command line. When a command line contains more than one switch, the create and edit switches are processed first, followed by the load and display switches.

Every time a DAVFU file is created, the extension .VF is attached to the filename. However, you do not need to specify the extension in a VFU command line. The format of a VFU command line is:

`VFU/[switches]vfu-filename`

Table 4.1 lists all of the switches and their meanings. Global switches follow the command name and local switches follow the argument.

Switch	Action
<b>Global Switches:</b>	
/A	Allows user programs to access the line printer's memory. This switch is used without an argument.
/C	Creates a VFU file. The utility asks questions about the tab and VFU control that you want in a specific .VF file.
/D	Disables user program access to the printer's memory. This switch is used without an argument.
/E	Edits an existing VFU file. VFU allows you to set or clear tab stops and VFU control entries.
/L	Prints page format settings of an existing .VF filename on \$LPT.
/S	Secondary printer. Loads into or lists on \$LPT1, depending on other switches.
/V	Displays the current page format settings of a .VF file on the console.
/X	Loads filename into the primary memory of the line printer (\$LPT). You can omit all switches to do this.
<b>Local Switches:</b>	
/L	Sends page format settings list for filename to this file.

Table 4.1 VFU command switches

## Creating a Vertical Format File

To create a Vertical Format (.VF) file you must use the /C switch in the command line. Once the utility recognizes this switch, it responds by creating *filename.VF*.

VFU continues with the following questions and directions.

**TAB CONTROL:**  
**WANT STANDARD TABS (EVERY 8 COLUMNS)?**  
**ENTER Y/N ==>**

Type Y if you want standard tab stops with intervals of eight spaces beginning at 0 and continuing with 7, 15, 23, up to column 127. The utility continues with the question on VFU control.

Type N if you want to set your own tab stops. The utility now asks you to enter the specific column numbers to be set.

**ENTER COLUMN NO. (1-132) OR CR ==>**

Type the number of each column at which you want a tab stop, followed by a Carriage Return ((CR)). Press the Carriage Return key by itself when all tab stops are set and you are ready to continue with the file.

**VFU CONTROL:**  
**WANT STANDARD (11 INCH)?**  
**ENTER Y/N ==>**

Type Y if you want the standard 11-inch form length (66 lines). The standard form length sets line 1 to channel 1, indicating the top of the form, and sets line 63 to channel 12, the end of the form. A .VF file is now complete and is written to disk.

Type N if you want to set your own form length. Continue with the next direction.

**ENTER FORM SIZE IN LINES (1-143) ==>**

Type a number between 1 and 143 representing the total length of the form. If the number is greater than the maximum allowed, the direction is repeated.

**ENTER LINE NUMBER OR CR ==>**

Type the line numbers to which you want to direct the printer. Setting channels in response to the next direction allows the printer to start printing information at a specific position on your form. When you do not specify any line numbers, the default sets line 1 to channel 1 and the line number indicated in the previous question to channel 12. Press the Carriage Return key by itself to continue.

**ENTER CHANNEL NO. (1-12) ==>**

Type the channel number that you want associated with the line number you gave in response to the last direction. Channel 1 always indicates the beginning of the form, and channel 12 always indicates the end of the form. Channels 2 through 11 can be used to instruct the printer to stop at a specific line and do not have to be set in numerical order. The utility continues to ask for line and channel numbers until you press the Carriage Return by itself.

You have created a complete .VF file which has been written to disk. Figure 4.1 is a flowchart for the process of creating a .VF file.

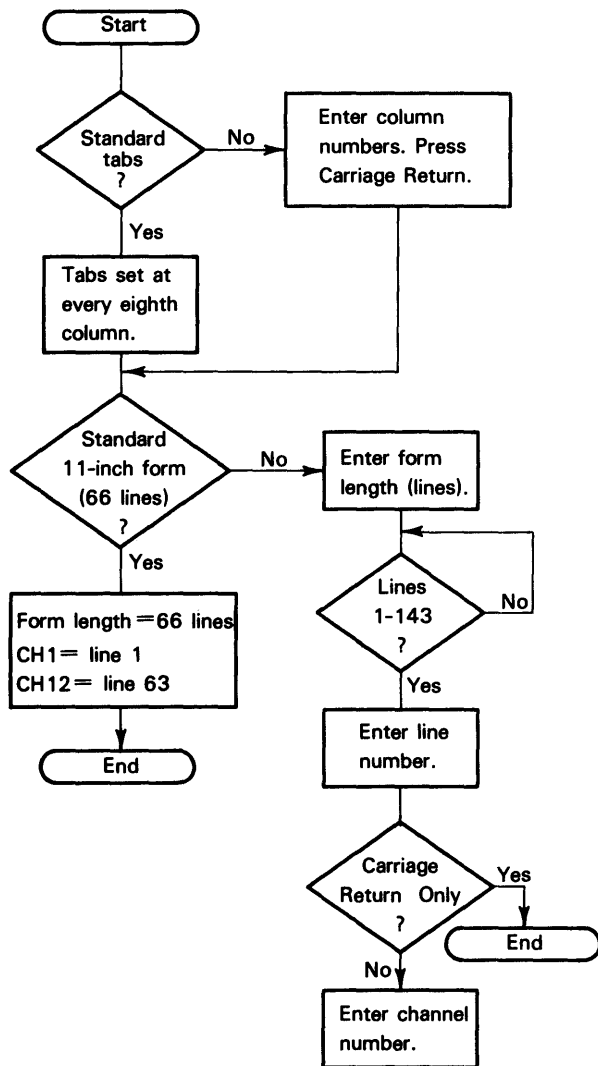

Figure 4.1 Creating a .VF file

The following sequence creates a VFU file called PAYROLL1.VF.

```

R
VFU/C PAYROLL1
DATA CHANNEL LINE PRINTER
FORMAT CONTROL PROGRAM
CREATING PAYROLL1.VF
TAB CONTROL:
WANT STANDARD TABS (EVERY 8 COLUMNS)?
ENTER Y/N ==> N
ENTER COLUMN NO. (1-132) OR CR ==> 3
ENTER COLUMN NO. (1-132) OR CR ==> 9
ENTER COLUMN NO. (1-132) OR CR ==> 16
ENTER COLUMN NO. (1-132) OR CR ==> 28
ENTER COLUMN NO. (1-132) OR CR ==> 50
ENTER COLUMN NO. (1-132) OR CR ==>
VFU CONTROL:
WANT STANDARD (11 INCH)?
ENTER Y/N ==> N
ENTER FORM SIZE IN LINES (1-143) ==> 44
ENTER LINE NUMBER OR CR ==> 1
ENTER CHANNEL NO. (1-12) ==> 1
ENTER LINE NUMBER OR CR ==> 4
ENTER CHANNEL NO. (1-12) ==> 2
ENTER LINE NUMBER OR CR ==> 9
ENTER CHANNEL NO. (1-12) ==> 3
ENTER LINE NUMBER OR CR ==> 41
ENTER CHANNEL NO. (1-12) ==> 12
ENTER LINE NUMBER OR CR ==>
R
  
```

## Displaying a VFU File Setting

File settings can be displayed in various ways, depending on the switches specified. These switches are listed in Table 4.2.

Switch	Action
<b>Global Switches</b>	
/L	Displays the settings of <i>vf</i> -filename on the first line printer.
/S	Displays the settings of <i>vf</i> -filename on the secondary line printer.
/V	Displays the settings of <i>vf</i> -filename on the console.
<b>Local Switches</b>	
/L	Sends the settings to the file named. (This switch overrides the global /L.)

Table 4.2 File setting switches

VFU displays the tab-stop and VFU channel settings or sends them to the specified file. It shows line-number/channel settings in the form *n-c*, where *n* is the line number of a setting and *c* is the channel number of a setting. When you default during the process of creating a file—thus specifying 11-inch forms—VFU channels would be:

1-1 63-12

## Editing a VFU File

When you specify a display option along with the switch /E, the current settings in *vfufilename* will be displayed, and VFU will then enter its editing mode. Now you can edit the VFU file by answering the following questions:

**TAB CONTROL:**

ENTER COLUMN NO. (1-132) OR CR ==>

Type the column number at which you want to set a new tab or clear an old tab, and press the Carriage Return ((CR)).

ENTER SET(S) OR CLEAR (C) ==>

Type S to set a tab at the column number specified in the previous step or C to clear a tab at this column. The utility returns to the first question again; this loop continues until you type a Carriage Return by itself.

**VFU CONTROL:**

ENTER LINE NUMBER OR CR ==>

Type the line number of a channel that you wish to set or clear, and then press the Carriage Return. VFU continues with the next direction.

ENTER CHANNEL NO. (1-12) ==>

Type the channel number associated with the line number (for Set) or the channel number that is already associated with the line number (for Clear). The utility continues with the following direction.

ENTER SET (S) OR CLEAR (C) ==>

Type S to set a new channel and type C to clear an existing channel setting. These final three steps are repeated until you respond to the direction about the line number by pressing a Carriage Return.

VFU now updates the existing *vfufilename* with the new setting and displays the new settings on the display file you specified.

Following is an example of the commands needed to display and edit the VFU file PAYROLL1.VF.

```
R
VFU/VE PAYROLL1
DATA CHANNEL LINE PRINTER
FORMAT CONTROL PROGRAM
PAYROLL1.VF 09/28/81 10:08:27
TAB STOPS:
3,9,16,28,50
VFU CHANNELS:
1-1,4-2,9-3,41-12
```

EDITING PAYROLL1.VF

```
TAB CONTROL:
ENTER COLUMN NO. (0-132) OR CR ==> 8
ENTER SET(S) OR CLEAR(C) ==> S
ENTER COLUMN NO. (0-132) OR CR ==> 9
ENTER SET(S) OR CLEAR(C) ==> C
ENTER COLUMN NO. (0-132) OR CR ==>
VFU CONTROL:
ENTER LINE NUMBER OR CR ==> 14
ENTER CHANNEL NO. (1-2) ==> 4
ENTER LINE NUMBER OR CR ==>
PAYROLL1.VF 09/28/81 10:15:37
TABSTOPS:
3,8,16,28,50
VFU CHANNELS:
1-1,4-2,9-3,14-4,41-12
R
```

## Accessing the Printer's Memory

User programs can access the printer's memory directly to change tab and VFU settings after you type VFU/A or VFU/A/S for the second printer. The printer memory is unprotected until you load a VFU file or disable access with VFU/D or VFU/D/S.

The following sequence enables and then disables access to the printer's memory with the program INVOICEAPR.SV.

```
R
VFU/A
DATA CHANNEL LINE PRINTER
FORMAT CONTROL PROGRAM
ENABLING ACCESS TO PRINTER
CONTROL MEMORY
R
INVOICEAPR
```

```
R
VFU/D
DATA CHANNEL LINE PRINTER
FORMAT CONTROL PROGRAM
DISABLING ACCESS TO PRINTER
CONTROL MEMORY
R
```

## Loading a File Into the Printer's Memory

To load a file into the printer's memory you must type VFU *filename* or VFU/X *filename*. The file will be loaded to the first data channel line printer with these two commands.

You can also use the /S switch, which will load the file to the secondary data channel line printer. VFU then displays the following message:

```
DATA CHANNEL LINE PRINTER FORMAT
CONTROL PROGRAM
PREPARE TO LOAD PAYROLL1.VF
WAIT UNTIL OUTPUT TO THE PRINTER HAS COMPLETED.
MAKE SURE THE PRINTER IS READY AND ON-LINE.
STRIKE ANY KEY WHEN READY.
```

When you press a key and the printer is ready, VFU disables spooling and transfers the VFU file into the printer's memory, after which the previous spooling state is restored. You can then print files using the page format control specified by the VFU file.

The command

```
VFU PAYROLL1
```

loads the VFU file PAYROLL1.VF into the printer's memory. Loading the DAVFU does not provide automatic forms indexing to the selected channels. This is done with an additional 2-byte command sequence discussed in the next section.

## Indexing to Selected Channels

The DAVFU-controlled forms indexing feature is a flexible, runtime-selectable feature consisting of a 2-byte command sequence. These two bytes must be preceded by a line termination character (Form-Feed or Carriage Return) for proper operation. The format of the control sequence is:

`<022 > <control byte>`

The DAVFU control sequence can be followed by any combination of printable characters, the horizontal tab character, and line terminators. The control byte allows the selection of indexing to any of 12 channels or the skipping of up to 15 lines. The format of the control byte is:

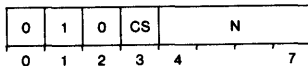

### Control Select (CS)

CS = 0: Skip to channel  $n + 1$ , where  $n$  is the channel number minus 1, in the range between 0 and 11 (decimal).

CS = 1: Skip  $n$  lines, where  $n$  is in the range between 0 and 15 (decimal).

Tables 4.3 and 4.4 list the DAVFU control byte codes.

Channel	Binary	Control Code		ASCII
		Octal	Decimal	
1	010 0 0000	100	64	@
2	010 0 0001	101	65	A
3	010 0 0010	102	66	B
4	010 0 0011	103	67	C
5	010 0 0100	104	68	D
6	010 0 0101	105	69	E
7	010 0 0110	106	70	F
8	010 0 0111	107	71	G
9	010 0 1000	110	72	H
10	010 0 1001	111	73	I
11	010 0 1010	112	74	J
12	010 0 1011	113	75	K

Table 4.3 DAVFU control byte codes for skip to channel

N	Binary	Control Code		ASCII
		Octal	Decimal	
0	010 1 0000	120	80	P
1	010 1 0001	121	81	Q
2	010 1 0010	122	82	R
3	010 1 0011	123	83	S
4	010 1 0100	124	84	T
5	010 1 0101	125	85	U
6	010 1 0110	126	86	V
7	010 1 0111	127	87	W
8	010 1 1000	130	88	X
9	010 1 1001	131	89	Y
10	010 1 1010	132	90	Z
11	010 1 1011	133	91	[
12	010 1 1100	134	92	
13	010 1 1101	935	93	]
14	010 1 1110	136	94	
15	010 1 1111	137	95	(underscore)

Table 4.4 DAVFU control byte codes

## Indexing Cautions

Be aware of two situations when indexing.

First, setting VFU channels on two successive lines indexes the selected channel on the next form. For example, suppose you set channel  $n$  on line  $L$  and another channel at line  $L + 1$ . The current form indexes to channel  $n$ , and prints line  $L$ . Upon receipt of a line terminator, the printer indexes the form to line  $L + 1$ . If at this point the DAVFU is instructed to index to a channel set to line  $L + 1$  (now the current line), it obliges by indexing to the same line on the next form.

Second, a form also skips when indexing from channel 12 to channel 1, when channel 1 is set at the top-of-form position and channel 12 is set at the bottom-of-form position, so that these two lines are physically contiguous and on opposite sides of the perforation on the form. When you print on the last line of a form and then index to channel 1, the next form is skipped, because the last line of the current form has already positioned the first line of the next form at the printing station. When you do not need to print on the last line, index directly to channel 1 to get to the first printing position of the next form; do not index to channel 12 before returning to channel 1.

## Sort/Merge Error Messages

RDOS Sort/Merge produces two types of error messages. These messages result from either a nonsystem or a system error.

The nonsystem error message is output to the listing file (if one has been specified) or to the console output device. The format of a nonsystem error is:

*GENERATOR - (error message)*

where *(error message)* is one of the messages described in the following text.

RDOS Sort/Merge produces the system error message any time the utility is unable to complete a system action such as creating, deleting, opening, closing, reading, or writing a file; loading an overlay; or extending the size of the user program space. The format of a system error message is:

*(filename) - (error message)*

where *(filename)* is the name of the last file or program segment referenced by the program and *(error message)* is one of the messages described in the following text. The filename can also be the name of one of the phases of RDOS Sort/Merge. The following are all possible filenames:

GENERATOR,  
PRESORT,  
LASTPASS,  
SORT/MERGE,  
MERGE

The filename can also be the name of a file referenced by one of the phases of RDOS Sort/Merge, such as:

RDOSSORT.OL,  
*(inputfile)*,  
*(outputfile)*,  
*(collate file)*,  
*(key file)*

### Error Messages

The following are the error messages produced by RDOS Sort/Merge.

#### *DUPLICATE KEY FILES*

You have specified two or more files to contain the record number and control field data.

#### *DUPLICATE LISTING FILES*

You have specified two or more listing files in the command line.

#### *DUPLICATE LOWER LIMIT KEY FILE NAMES*

You specified more than one lower limit filename in the command line.

#### *DUPLICATE OUTPUT FILES*

You specified more than one output file in the command line.

#### *DUPLICATE SEQUENCE FILES*

You have specified two or more files containing alternate collating sequences in the command line.

#### *DUPLICATE UPPER LIMIT KEY FILE NAMES*

You specified more than one upper limit filename in the command line.

#### *ILLEGAL RECORD SIZE*

You specified a record length in the command line that was larger than 512.

#### *INPUT RECORD TOO SMALL*

In the command line, you specified a record length of zero or a length less than the record length needed to contain the specified control fields.

**INSUFFICIENT MEMORY FOR PRESORT**

Enough memory must be present to sort at least ten records at one time. To proceed, you could use a smaller control field.

**INVALID KEY SPECIFIERS**

You have set up the key (control field) for either input or output incorrectly; for example, you may have entered a non-numeric character or omitted the period or colon between the start position and field length.

**KEY RANGE ERROR**

The input or output key field specified did not exist completely within the record as indicated by the user or the default record size (80 bytes).

**NO INPUT FILE SPECIFIED FOR RDOSSORT**

You must specify at least one input file for RDOS Sort/Merge to operate.

**NO KEY OR OUTPUT FILE FOR RDOSSORT**

You must specify at least one of these files for RDOS Sort/Merge to function.

**NO KEY SPECIFIERS**

You did not specify any key field in the command line. One or more are required for operation in either sort or merge modes.

**NO OUTPUT FILE SPECIFIED FOR MERGE MODE**

You neglected to specify an output file for merge mode.

**TOO MANY INPUT FILES SPECIFIED**

You specified more than one input file for a sort operation or more than six input files for the merge operation.

**TOO MANY KEY SPECIFIERS**

You have specified more than eight input or output control fields in the command line.

**TOO MANY WORK FILES SPECIFIED**

You specified more than six work files in the command line.

**UNIDENTIFIED LOCAL SWITCH**

You have used a local switch that RDOS Sort/Merge cannot recognize during the generation phase.



## Timing and Storage Considerations

The time needed to run a sort or merge job can vary greatly depending on the size of the main storage, the number of records to be sorted, the record/control field size, the collating sequence, and the location of the files. This appendix explains how each of these factors can affect the length of time required to run your job.

### Main Storage Size

The amount of main storage available for the sort program will affect the length of time it takes to execute a job. The more main memory storage the utility has to use, the greater the number of control fields you can specify. Larger main memory size also allows the use of longer input records. RDOS Sort/Merge uses all of the main storage that is available to it.

### Number of Records to be Sorted

Since the length of time that a job takes depends on the number of records you want to sort, you should use the record limit feature whenever possible, so that only the records you are interested in are included.

### Record/Control Field Size

If the keys are large, it will take longer to sort a file, since only a small number of keys can be sorted in main memory. Your control fields should contain only pertinent information. Each extra character increases your runtime, and every control field you include increases the size of your work record.

### Alternate Collating Sequence

If you use an alternate collating sequence, you slightly increase the time it takes to run a sort job, because the utility has to translate the control fields.

### Location of the Files

File location affects the length of time required to run a sort job, because the RDOS Sort/Merge Utility must move each record from the input file to the output file. It is therefore important to place the high activity files—for example, the work files—on a fast access head/track disk whenever possible. When multiple disk packs or disk cartridge systems are available, the work files should be distributed over these disk units. Magnetic tape units can be used for work files or for the output file.

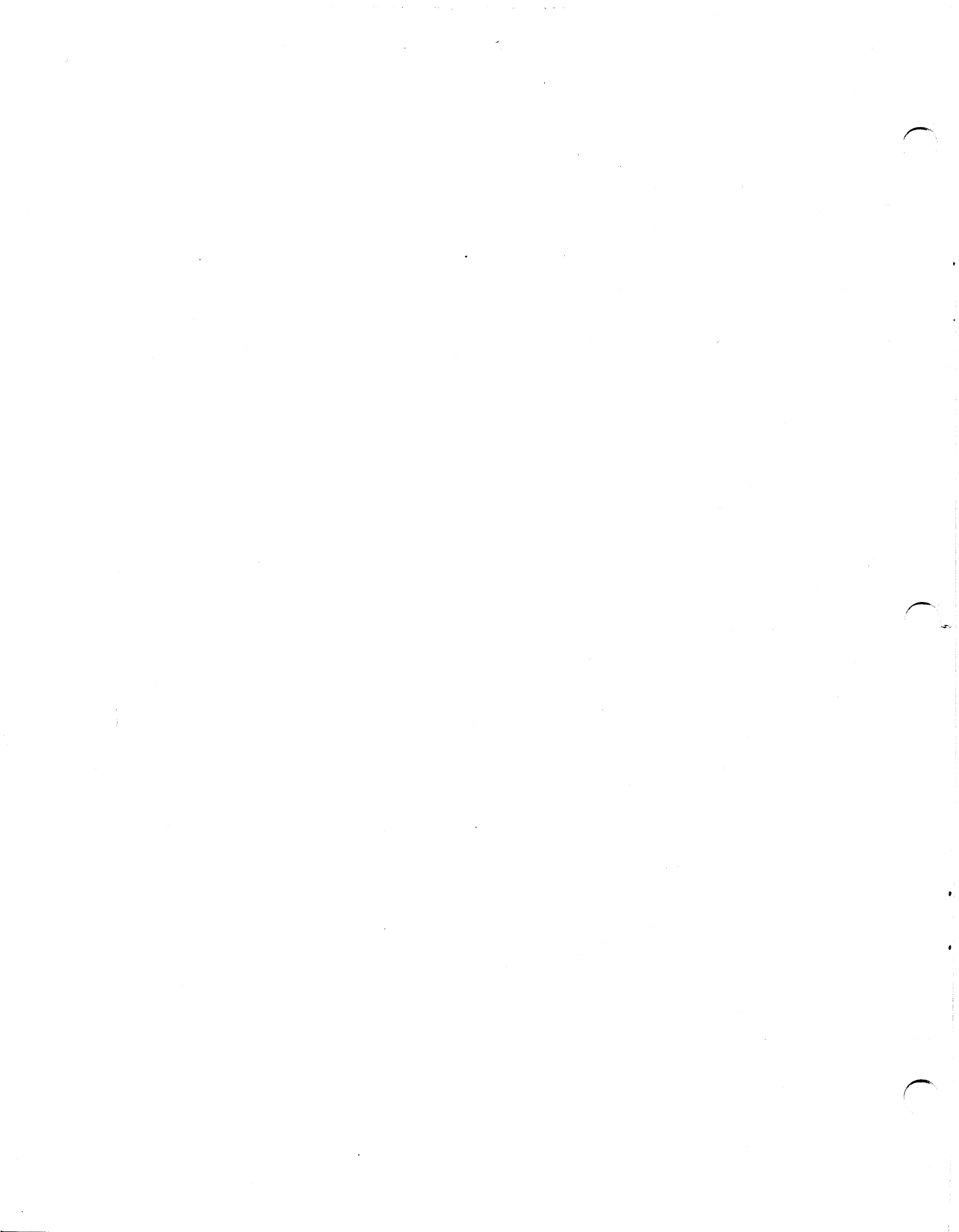

---

# Index

- .DV filename extension 15
  - .VF file 16-17
    - creating 16
  - /A (access printer's memory) 16
  - /A (enable DAVFU) 15
  - /B 15
  - /C 16
  - /D 16
  - /E 18
  - /L (display file settings of VFU-filename on primary printer) 17
  - /L (print page format for existing .VF filename) 17
  - /L (send VFU file settings to file named) 17
  - /S (display settings of VFU-filename on secondary printer) 17
  - /S (load or list onto primary printer) 16
  - /V 17
  - /X 16
- A**
- Alternative work files 9
- C**
- Channels 17-18
  - Collating sequence 7
    - during sort 11
  - Command line 16
    - global VFU switches for 16
    - switches in 7, 15
  - Command
    - RLDR RDOSSORT load 4
  - Commands 18
    - control limit specifications 9
    - operating Sort/Merge on mapped computer 5
  - Control byte codes 19
  - Control sequence 18
- D**
- DAVFU (Direct Access Vertical Format Unit) 15
    - control sequence 18
      - accessing 15
      - commands 15
      - control byte codes for skip to channel 19
      - control sequence format 19
      - file name extensions 15
  - Deleting records 3, 9
- E**
- Error messages 21
- F**
- Field specifiers, output 8
  - File names, specifying for DAVFU 15
  - File of selected items 23
  - File setting
    - VFU 17
  - File displaying
    - VFU 17
  - File types
    - .DV 15
    - limit 9
    - ordered item 23
    - relocatable binary files 4
    - work 9
  - Files 18
    - alternative work files 9
    - creating a .VF file 16-17
    - editing VFU files 18
    - merging 11
    - sorting 11
    - work 9
  - Form length 16
  - Format 17
    - .VF file creation 17
    - DAVFU control sequence 19
    - VFU file creation 15
    - channel numbers 17
    - errors, nonsystem 21
    - form length for .VF files 16
    - improper setting
    - output field specifier 8
    - records 3
    - system error messages 21, 23
    - record deletion 3
  - Forms 19

## I

Indexing 19  
  DAVFU-controlled forms 18  
  to selected channels 18-19  
  improper setting of forms 20  
Input 3  
  file 3  
  file characteristics 3  
Item file, ordered 23

## K

Key field  
  major 9  
  minor 8  
  specifier 8

## L

L/S 17  
Limit files 9  
Line format, .VF files 17

## M

Major key field 9  
Merge operating cycle 12  
Minor key fields 8

## O

Operating system 4, 15  
Ordered item file 23  
Output 15  
  field specifier 8

## P

Page format, changing 15

## R

RLDR RDOSSORT load command 4  
Records  
  collating sequence 3  
  deleting 3, 9  
  rearranging 3  
  reformatting 4  
  sorting and merging 11  
Relocatable binary files, SORTG.RB 4  
  listed 4

## S

SORTG.RB, relocatable binary files 4  
Setting forms 16-20

Skip to channel, control byte codes 19  
Sort/Merge, features 3  
  operating cycle 11  
Sorted tag file 11  
Specifiers, key field 8  
  output field 8  
Spooling 15  
Switches  
  /A (access printer's memory) 16  
  /A (enable DAVFU) 15  
  /B (disable DAVFU) 15  
  /C (create VFU file 16  
  /D (disable user program access to printer's memory) 16  
  /E (edit VFU files) 18  
  /L (print page format for existing .VF filename) 17  
  /L (send VFU file settings to file named) 17  
  /S (load or list onto primary lineprinter) 16  
  /V (display settings of VFU-filename) 17  
  /X (load filename into primary memory of lineprinter)  
  16  
L/S (display settings of VFU-filename on secondary  
  printer) 17  
access the DAVFU 15  
combining 15  
display 17  
Sort/Merge command line 7  
VFU command lines 16

## T

Tabs clearing 18  
  creating 16  
  displaying 18  
  setting and clearing 18  
Tag file 11  
  sorted 11  
Temporary workspace 3  
Timing and storage 23

## V

VFU 18  
  channels 20, 21  
  control 16-17  
  described 15  
  editing 18  
  file  
  creating 17  
  displaying tabs and settings 18  
  editing 18  
  setting 17  
  functions 15  
  settings 18  
  switches 16, 18  
  tab control 18  
Vertical Format Utility (See VFU)

## W

Work files 9-11  
  merging 11  
Work records 11

## DG OFFICES

### NORTH AMERICAN OFFICES

**Alabama:** Birmingham  
**Arizona:** Phoenix, Tucson  
**Arkansas:** Little Rock  
**California:** Anaheim, El Segundo, Fresno, Los Angeles, Oakland, Palo Alto, Riverside, Sacramento, San Diego, San Francisco, Santa Barbara, Sunnyvale, Van Nuys  
**Colorado:** Colorado Springs, Denver  
**Connecticut:** North Branford, Norwalk  
**Florida:** Ft. Lauderdale, Orlando, Tampa  
**Georgia:** Norcross  
**Idaho:** Boise  
**Iowa:** Bettendorf, Des Moines  
**Illinois:** Arlington Heights, Champaign, Chicago, Peoria, Rockford  
**Indiana:** Indianapolis  
**Kentucky:** Louisville  
**Louisiana:** Baton Rouge, Metairie  
**Maine:** Portland, Westbrook  
**Maryland:** Baltimore  
**Massachusetts:** Cambridge, Framingham, Southboro, Waltham, Wellesley, Westboro, West Springfield, Worcester  
**Michigan:** Grand Rapids, Southfield  
**Minnesota:** Richfield  
**Missouri:** Creve Coeur, Kansas City  
**Mississippi:** Jackson  
**Montana:** Billings  
**Nebraska:** Omaha  
**Nevada:** Reno  
**New Hampshire:** Bedford, Portsmouth  
**New Jersey:** Cherry Hill, Somerset, Wayne  
**New Mexico:** Albuquerque  
**New York:** Buffalo, Lake Success, Latham, Liverpool, Melville, New York City, Rochester, White Plains  
**North Carolina:** Charlotte, Greensboro, Greenville, Raleigh, Research Triangle Park  
**Ohio:** Brooklyn Heights, Cincinnati, Columbus, Dayton  
**Oklahoma:** Oklahoma City, Tulsa  
**Oregon:** Lake Oswego  
**Pennsylvania:** Blue Bell, Lancaster, Philadelphia, Pittsburgh  
**Rhode Island:** Providence  
**South Carolina:** Columbia  
**Tennessee:** Knoxville, Memphis, Nashville  
**Texas:** Austin, Dallas, El Paso, Ft. Worth, Houston, San Antonio  
**Utah:** Salt Lake City  
**Virginia:** McLean, Norfolk, Richmond, Salem  
**Washington:** Bellevue, Richland, Spokane  
**West Virginia:** Charleston  
**Wisconsin:** Brookfield, Grand Chute, Madison

DG-04976

### INTERNATIONAL OFFICES

**Argentina:** Buenos Aires  
**Australia:** Adelaide, Brisbane, Hobart, Melbourne, Newcastle, Perth, Sydney  
**Austria:** Vienna  
**Belgium:** Brussels  
**Bolivia:** La Paz  
**Brazil:** Sao Paulo  
**Canada:** Calgary, Edmonton, Montreal, Ottawa, Quebec, Toronto, Vancouver, Winnipeg  
**Chile:** Santiago  
**Columbia:** Bogota  
**Costa Rica:** San Jose  
**Denmark:** Copenhagen  
**Ecuador:** Quito  
**Egypt:** Cairo  
**Finland:** Helsinki  
**France:** Le Plessis-Robinson, Lille, Lyon, Nantes, Paris, Saint Denis, Strasbourg  
**Guatemala:** Guatemala City  
**Hong Kong**  
**India:** Bombay  
**Indonesia:** Jakarta, Pusat  
**Ireland:** Dublin  
**Israel:** Tel Aviv  
**Italy:** Bologna, Florence, Milan, Padua, Rome, Turin  
**Japan:** Fukuoka, Hiroshima, Nagoya, Osaka, Tokyo, Tsukuba  
**Jordan:** Amman  
**Korea:** Seoul  
**Kuwait:** Kuwait  
**Lebanon:** Beirut  
**Malaysia:** Kuala Lumpur  
**Mexico:** Mexico City, Monterrey  
**Morocco:** Casablanca  
**The Netherlands:** Amsterdam, Rijswijk  
**New Zealand:** Auckland, Wellington  
**Nicaragua:** Managua  
**Nigeria:** Ibadan, Lagos  
**Norway:** Oslo  
**Paraguay:** Asuncion  
**Peru:** Lima  
**Philippine Islands:** Manila  
**Portugal:** Lisbon  
**Puerto Rico:** Hato Rey  
**Saudi Arabia:** Jeddah, Riyadh  
**Singapore**  
**South Africa:** Cape Town, Durban, Johannesburg, Pretoria  
**Spain:** Barcelona, Bilbao, Madrid  
**Sweden:** Gothenburg, Malmo, Stockholm  
**Switzerland:** Lausanne, Zurich  
**Taiwan:** Taipei  
**Thailand:** Bangkok  
**Turkey:** Ankara  
**United Kingdom:** Birmingham, Bristol, Glasgow, Hounslow, London, Manchester  
**Uruguay:** Montevideo  
**USSR:** Espoo  
**Venezuela:** Maracaibo  
**West Germany:** Dusseldorf, Frankfurt, Hamburg, Hannover, Munich, Nuremberg, Stuttgart



# Ordering Technical Publications

---

TIPS is the Technical Information and Publications Service—a new support system for DGC customers that makes ordering technical manuals simple and fast. Simple, because TIPS is a central supplier of literature about DGC products. And fast, because TIPS specializes in handling publications.

TIPS was designed by DG's Educational Services people to follow through on your order as soon as it's received. To offer discounts on bulk orders. To let you choose the method of shipment you prefer. And to deliver within a schedule you can live with.

---

## How to Get in Touch with TIPS

Contact your local DGC education center for brochures, prices, and order forms. Or get in touch with a TIPS administrator directly by calling (617) 366-8911, extension 4086, or writing to

Data General Corporation  
Attn: Educational Services, TIPS Administrator  
MS F019  
4400 Computer Drive  
Westborough, MA 01580

TIPS. For the technical manuals you need, when you need them.

---

## DGC Education Centers

Boston Education Center  
Route 9  
Southboro, Massachusetts 01772  
(617) 485-7270

Washington, D.C. Education Center  
7927 Jones Branch Drive, Suite 200  
McLean, Virginia 22102  
(703) 827-9666

Atlanta Education Center  
6855 Jimmy Carter Boulevard, Suite 1790  
Norcross, Georgia 30071  
(404) 448-9224

Los Angeles Education Center  
5250 West Century Boulevard  
Los Angeles, California 90045  
(213) 670-4011

Chicago Education Center  
703 West Algonquin Road  
Arlington Heights, Illinois 60005  
(312) 364-3045





# User Documentation Remarks Form

Your Name \_\_\_\_\_ Your Title \_\_\_\_\_  
 Company \_\_\_\_\_  
 Street \_\_\_\_\_  
 City \_\_\_\_\_ State \_\_\_\_\_ Zip \_\_\_\_\_

We wrote this book for you, and we made certain assumptions about who you are and how you would use it. Your comments will help us correct our assumptions and improve the manual. Please take a few minutes to respond. Thank you.

Manual Title \_\_\_\_\_ Manual No. \_\_\_\_\_

Who are you?  EDP Manager  Analyst/Programmer  Other \_\_\_\_\_  
 Senior Systems Analyst  Operator \_\_\_\_\_

What programming language(s) do you use? \_\_\_\_\_

How do you use this manual? (List in order: 1 = Primary Use) \_\_\_\_\_

\_\_\_ Introduction to the product    \_\_\_ Tutorial Text    \_\_\_ Other  
 \_\_\_ Reference    \_\_\_ Operating Guide

About the manual:		Yes	Somewhat	No
Is it easy to read?		<input type="checkbox"/>	<input type="checkbox"/>	<input type="checkbox"/>
Is it easy to understand?		<input type="checkbox"/>	<input type="checkbox"/>	<input type="checkbox"/>
Are the topics logically organized?		<input type="checkbox"/>	<input type="checkbox"/>	<input type="checkbox"/>
Is the technical information accurate?		<input type="checkbox"/>	<input type="checkbox"/>	<input type="checkbox"/>
Can you easily find what you want?		<input type="checkbox"/>	<input type="checkbox"/>	<input type="checkbox"/>
Does it tell you everything you need to know		<input type="checkbox"/>	<input type="checkbox"/>	<input type="checkbox"/>
Do the illustrations help you?		<input type="checkbox"/>	<input type="checkbox"/>	<input type="checkbox"/>

If you have any comments on the software itself, please contact Data General Systems Engineering.  
 If you wish to order manuals, use the enclosed TIPS Order Form (USA only).

Remarks:

Date

CUT ALONG DOTTED LINE

FOLD

FOLD

TAPE

TAPE

FOLD

FOLD



NO POSTAGE  
NECESSARY  
IF MAILED  
IN THE  
UNITED STATES

**BUSINESS REPLY MAIL**  
FIRST CLASS PERMIT NO. 26 SOUTHBORO, MA. 01772

Postage will be paid by addressee:

 **Data General**

**ISD User Documentation, M.S. E-111**

**4400 Computer Drive**

**Westboro, MA 01581**

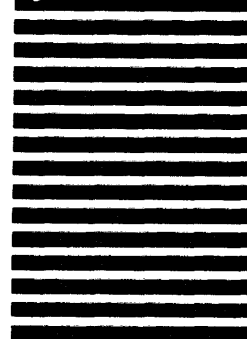

# User Documentation Remarks Form

Your Name \_\_\_\_\_ Your Title \_\_\_\_\_  
Company \_\_\_\_\_  
Street \_\_\_\_\_  
City \_\_\_\_\_ State \_\_\_\_\_ Zip \_\_\_\_\_

We wrote this book for you, and we made certain assumptions about who you are and how you would use it. Your comments will help us correct our assumptions and improve the manual. Please take a few minutes to respond.

Thank you. *RDOS/DOS Sort/Merge*  
Manual Title *and Vertical Format Unit Utilities* Manual No. *069-400021-00*

Who are you?  EDP Manager  Analyst/Programmer  Other \_\_\_\_\_  
 Senior Systems Analyst  Operator \_\_\_\_\_

What programming language(s) do you use? \_\_\_\_\_

How do you use this manual? (List in order: 1 = Primary Use) \_\_\_\_\_

Introduction to the product  Tutorial Text  Other \_\_\_\_\_  
 Reference  Operating Guide \_\_\_\_\_

About the manual:		Yes	Somewhat	No
Is it easy to read?		<input type="checkbox"/>	<input type="checkbox"/>	<input type="checkbox"/>
Is it easy to understand?		<input type="checkbox"/>	<input type="checkbox"/>	<input type="checkbox"/>
Are the topics logically organized?		<input type="checkbox"/>	<input type="checkbox"/>	<input type="checkbox"/>
Is the technical information accurate?		<input type="checkbox"/>	<input type="checkbox"/>	<input type="checkbox"/>
Can you easily find what you want?		<input type="checkbox"/>	<input type="checkbox"/>	<input type="checkbox"/>
Does it tell you everything you need to know?		<input type="checkbox"/>	<input type="checkbox"/>	<input type="checkbox"/>
Do the illustrations help you?		<input type="checkbox"/>	<input type="checkbox"/>	<input type="checkbox"/>

If you have any comments on the software itself, please contact Data General Systems Engineering.  
If you wish to order manuals, use the enclosed TIPS Order Form (USA only).

Remarks:

Date

CUT ALONG DOTTED LINE

FOLD

FOLD

TAPE

TAPE

FOLD

FOLD



NO POSTAGE  
NECESSARY  
IF MAILED  
IN THE  
UNITED STATES

**BUSINESS REPLY MAIL**  
FIRST CLASS PERMIT NO. 26 SOUTHBORO, MA. 01772

Postage will be paid by addressee:

 **Data General**

**ISD User Documentation, M.S. E-111**

**4400 Computer Drive**

**Westboro, MA 01581**



# DataGeneral Users group

## Installation Membership Form

Name \_\_\_\_\_ Position \_\_\_\_\_ Date \_\_\_\_\_

Company, Organization or School \_\_\_\_\_

Address \_\_\_\_\_ City \_\_\_\_\_ State \_\_\_\_\_ Zip \_\_\_\_\_

Telephone: Area Code \_\_\_\_\_ No. \_\_\_\_\_ Ext. \_\_\_\_\_

### 1. Account Category

- OEM  
 End User  
 System House  
 Government

### 5. Mode of Operation

- Batch (Central)  
 Batch (Via RJE)  
 On-Line Interactive

### 2. Hardware

Qty. Installed | Qty. On Order

M/600  
 MV/Series ECLIPSE\*  
 Commercial ECLIPSE  
 Scientific ECLIPSE  
 Array Processors  
 CS Series  
 NOVA<sup>2</sup> 4 Family  
 Other NOVAs  
 microNOVA<sup>2</sup> Family  
 MPT Family

Qty. Installed	Qty. On Order
_____	_____
_____	_____
_____	_____
_____	_____
_____	_____
_____	_____
_____	_____
_____	_____
_____	_____
_____	_____
_____	_____

Other \_\_\_\_\_  
 (Specify) \_\_\_\_\_

### 6. Communication

- HASP       X.25  
 HASP II     SAM  
 RJE80       CAM  
 RCX 70      XODIAC™  
 RSTCP       DG/SNA  
 4025        3270  
 Other

Specify \_\_\_\_\_

### 7. Application Description

○ \_\_\_\_\_  
 \_\_\_\_\_  
 \_\_\_\_\_  
 \_\_\_\_\_

### 3. Software

- AOS       RDOS  
 AOS/VS    DOS  
 AOS/RT32  RTOS  
 MP/OS     Other  
 MP/AOS

Specify \_\_\_\_\_

### 8. Purchase

From whom was your machine(s) purchased?

- Data General Corp.  
 Other  
 Specify \_\_\_\_\_

### 4. Languages

- ALGOL     BASIC  
 DG/L      Assembler  
 COBOL    FORTRAN 77  
 Interactive  FORTRAN 5  
           COBOL     RPG II  
 PASCAL    PL/1  
 Business  APL  
           BASIC     Other

Specify \_\_\_\_\_

### 9. Users Group

Are you interested in joining a special interest or regional Data General Users Group?

○ \_\_\_\_\_  
 \_\_\_\_\_  
 \_\_\_\_\_



CUT ALONG DOTTED LINE

FOLD

FOLD

TAPE

TAPE

FOLD

FOLD



NO POSTAGE  
NECESSARY  
IF MAILED  
IN THE  
UNITED STATES

**BUSINESS REPLY MAIL**  
FIRST CLASS PERMIT NO. 26 SOUTHBORO, MA. 01772

Postage will be paid by addressee:

 **Data General**

ATTN: Users Group Coordinator (C-228)  
4400 Computer Drive  
Westboro, MA 01581

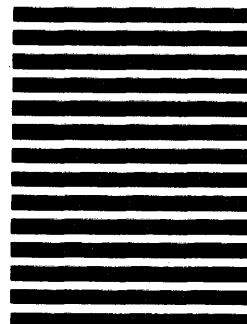

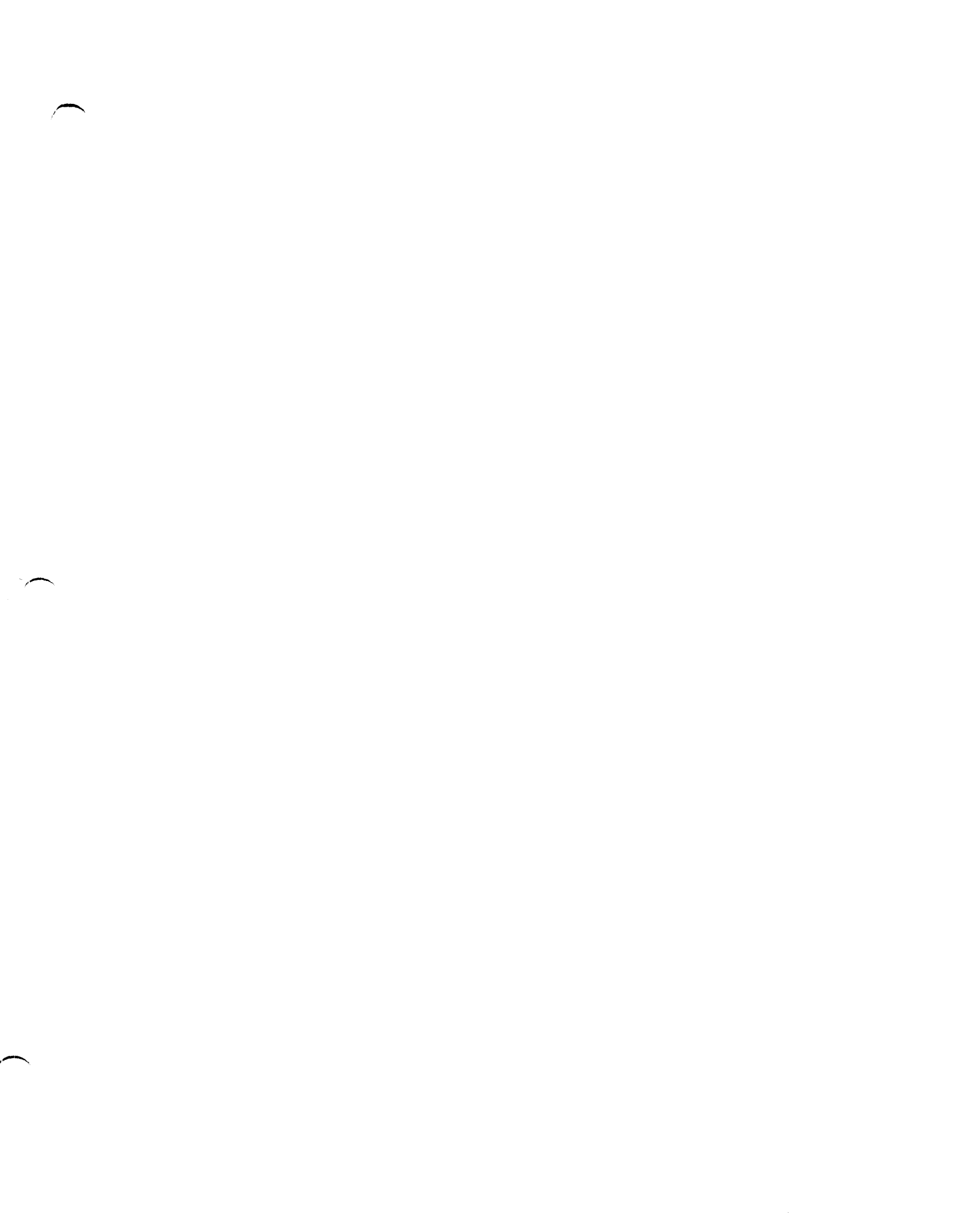



Data General Corporation, Westboro, Massachusetts 01580

069-400021-00