

THIS DRAWING AND SPECIFICATIONS, HEREIN, ARE THE PROPERTY OF DATA GENERAL CORPORATION AND SHALL NOT BE REPRODUCED OR COPIED OR USED IN WHOLE OR IN PART AS THE BASIS FOR MANUFACTURE OR SALE OF ITEMS WITHOUT WRITTEN PERMISSION.

| REVISIONS |  |        |          |          |
|-----------|--|--------|----------|----------|
| REV.      | DESCRIPTION  | DRFTG. | APP. BY  | DATE     |
|           | 1. ADD 100-Ω & 1200 P.F. TO DEMAND INPUT   |        |          |          |
| 01        | 2. DELETE "LPT SELECT" FROM BUS; ADD LPT INT REQ TO BUS                            |        | S.Booth  | 10/1/70  |
|           | 1. ADD WIRE TO PROPAGATE DCH P   |        |          |          |
|           | 2. ADD +3V SOURCE  |        | D.LAZUKA | 10/9/70  |
| 02        | 3. CORRECT OUTPUT PINS ON BUSY FLOP  |        |          |          |
| 03        | ECO # 1213, JUMPERS NO'S. W/ # W2 ADDED.   |        | R.W.C.   | 12-4-72  |
| 04        | ECO # 1283, R35 10KΩ CHANGED TO 56KΩ; U58 PIN 5 CHANGED TO PIN 6; PIN 6 " " PIN 5. |        | R.W.C.   | 12-27-72 |
| 05        | ECO # 1310, JUMPER NO'S W/ # W2 CHANGED. W1 TO W2 & W2 TO W3                       |        | R.W.C.   | 12-27-72 |
| 06        | ECO # 1613   |        | R.W.C.   | 5-14-74  |
| 07        | ECO # 2423   |        | REJ      | 6-15-74  |

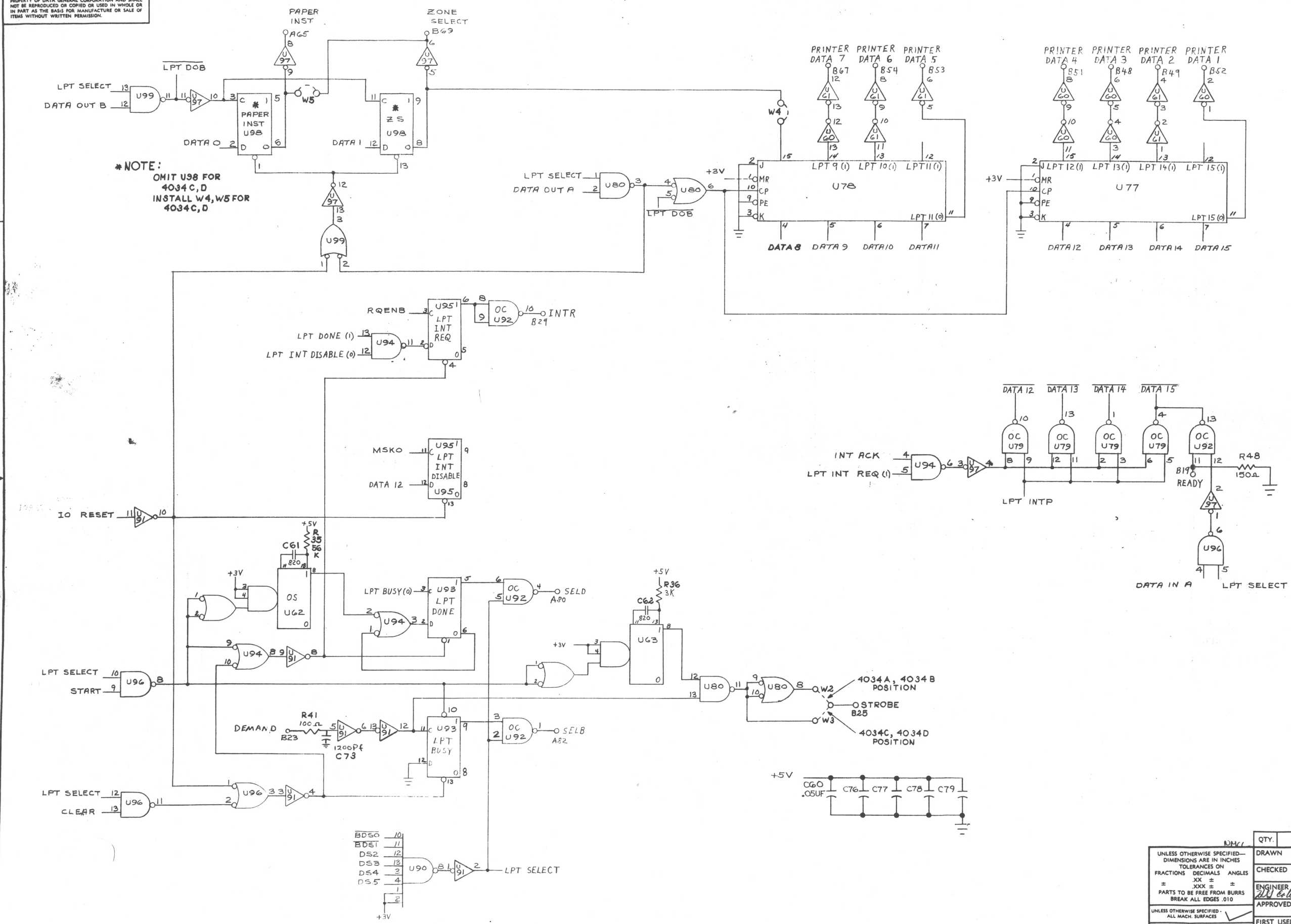

\*NOTE:  
OMIT U98 FOR  
4034C, D  
INSTALL W4, W5 FOR  
4034C, D

|  |               |             |          |
|--|---------------|-------------|----------|
| UNLESS OTHERWISE SPECIFIED—<br>DIMENSIONS ARE IN INCHES<br>TOLERANCES ON<br>FRACTIONS DECIMALS ANGLES<br>= .005 ± .005 ± .005 ±<br>PARTS TO BE FREE FROM BURRS<br>BREAK ALL EDGES .010 | QTY.          | DESCRIPTION | PART NO. |
|  | DRAWN         |             |          |
|  | CHECKED       |             |          |
|  | ENGINEER      |             |          |
| UNLESS OTHERWISE SPECIFIED—<br>ALL MACH. SURFACES  | FIRST USED ON | TYPE 4034   |          |
| MATERIAL   | SCALE         |             |          |
| FINISH   |               |             |          |

|                                |      |                |      |
|--------------------------------|------|----------------|------|
| DATA GENERAL CORPORATION       |      |                |      |
| SOUTHBORO, MASSACHUSETTS 01772 |      |                |      |
| TITLE                          |      |                |      |
| LINE PRINTER CONTROL           |      |                |      |
| (DATA PRODUCTS 2310, 2410)     |      |                |      |
| SIZE                           | CODE | DRAWING NUMBER | REV. |
| D                              | 001  | 000086         | 07   |